

OMNIMATE Signal - series BL/SL 3.50 BLL 3.50/06/180 3.2SN BK TU

Weidmüller Interface GmbH & Co. KG
Klingenbergstraße 26
D-32758 Detmold
Germany
Fon: +49 5231 14-0
Fax: +49 5231 14-292083
www.weidmueller.com

Product image

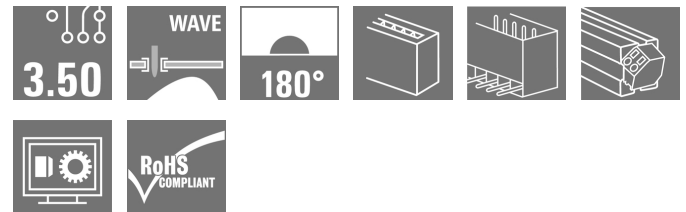

Similar to illustration

Inverted female header for:

- finger-safety on the PCB
- Board-to-board component connection (with SL/SL-SMT 3.50)
- Wave soldering
- Outlet direction: 180° (standing, vertical to PCB)

General ordering data

Type	BLL 3.50/06/180 3.2SN BK TU
Order No.	4309590000
Version	PCB plug-in connector, female header, closed side, THT solder connection, 3.50 mm, Number of poles: 6, 180°, Solder pin length (l): 3.2 mm, tinned, black, Tube
GTIN (EAN)	4032248526468
Qty.	25 pc(s).
Product data	IEC: 320 V / 15.1 A UL: 300 V / 9 A
Packaging	Tube

Creation date May 1, 2020 3:14:51 PM CEST

**OMNIMATE Signal - series BL/SL 3.50
BLL 3.50/06/180 3.2SN BK TU**

Weidmüller Interface GmbH & Co. KG
Klingenbergstraße 26
D-32758 Detmold
Germany
Fon: +49 5231 14-0
Fax: +49 5231 14-292083
www.weidmueller.com

Technical data**Dimensions and weights**

Height	14.3 mm	Height (inches)	0.563 inch
Depth	11.85 mm	Depth (inches)	0.467 inch
Net weight	3.56 g		

System specifications

Product family	OMNIMATE Signal - series BL/SL 3.50	Type of connection	Board connection
Mounting onto the PCB	THT solder connection	Pitch in mm (P)	3.5 mm
Pitch in inches (P)	0.138 inch	Outgoing elbow	180°
Number of poles	6	Number of solder pins per pole	1
Solder pin length (l)	3.2 mm	Solder pin length tolerance	+0.2 / -0.2 mm
Tolerance of solder pin position	± 0.1 mm	Solder pin dimensions	d = 0.8 mm
Solder pin dimensions = d tolerance	0 / -0,03 mm	Solder eyelet hole diameter (D)	1.3 mm
Solder eyelet hole diameter tolerance (D)+ 0,1 mm		L1 in mm	17.5 mm
L1 in inches	0.689 inch	Number of rows	1
Pin series quantity	1	Touch-safe protection acc. to DIN VDE 57 106	Safe from finger touch
Touch-safe protection acc. to DIN VDE 0470	IP 20	Volume resistance	≤ 5mΩ
Can be coded	Yes	Plugging cycles	25
Plugging force/pole, max.	8 N	Pulling force/pole, max.	7 N

Material data

Insulating material	PBT	Colour	black
Colour chart (similar)	RAL 9011	Insulating material group	IIIa
Comparative Tracking Index (CTI)	≥ 200	Insulation strength	≥ 10 ⁸ Ω
UL 94 flammability rating	V-0	GWFI	960 °C
Contact material	CuSn	Contact surface	tinned
Layer structure of solder connection	4-6 μm Sn glossy	Layer structure of plug contact	4-6 μm Sn glossy
Storage temperature, min.	-25 °C	Storage temperature, max.	50 °C
Max. relative humidity during storage	70 %	Operating temperature, min.	-50 °C
Operating temperature, max.	100 °C	Temperature range, installation, min.	-25 °C
Temperature range, installation, max.	100 °C		

Rated data acc. to IEC

tested acc. to standard	IEC 60664-1, IEC 61984	Rated current, min. number of poles (Tu=20°C)	15.1 A
Rated current, max. number of poles (Tu=20°C)	7.7 A	Rated current, min. number of poles (Tu=40°C)	13 A
Rated current, max. number of poles (Tu=40°C)	6.6 A	Rated voltage for surge voltage class / pollution degree II/2	320 V
Rated voltage for surge voltage class / pollution degree III/2	160 V	Rated voltage for surge voltage class / pollution degree III/3	160 V
Rated impulse voltage for surge voltage class/ pollution degree II/2	2.5 kV	Rated impulse voltage for surge voltage class/ pollution degree III/2	2.5 kV
Rated impulse voltage for surge voltage class/ contamination degree III/3	2.5 kV	Short-time withstand current resistance	3 x 1s with 100 A

**OMNIMATE Signal - series BL/SL 3.50
BLL 3.50/06/180 3.2SN BK TU**

Weidmüller Interface GmbH & Co. KG
 Klingenbergstraße 26
 D-32758 Detmold
 Germany
 Fon: +49 5231 14-0
 Fax: +49 5231 14-292083
 www.weidmueller.com

Technical data**Rated data acc. to CSA**

Institute (CSA)		Certificate No. (CSA)	200039-1121690
Rated voltage (Use group C / CSA)	300 V	Rated current (Use group C / CSA)	9 A
Reference to approval values	Specifications are maximum values, details - see approval certificate.		

Rated data acc. to UL 1059

Institute (cURus)		Certificate No. (cURus)	E60693
Rated voltage (Use group B / UL 1059)	300 V	Rated voltage (Use group D / UL 1059)	300 V
Rated current (Use group B / UL 1059)	9 A	Rated current (Use group D / UL 1059)	9 A
Reference to approval values	Specifications are maximum values, details - see approval certificate.		

Packing

Packaging	Tube	VPE length	18 mm
VPE width	20 mm	VPE height	555 mm
Surface resistance	$R_s = 10^9 - 10^{12} \Omega$		

Classifications

ETIM 6.0	EC002637	ETIM 7.0	EC002637
eClass 9.0	27-44-04-02	eClass 9.1	27-44-04-02
eClass 10.0	27-44-04-02		

Notes

Notes	<ul style="list-style-type: none"> • Additional colours on request • Gold-plated contact surfaces on request • Rated current related to rated cross-section & min. No. of poles. • P on drawing = pitch • Rated data refer only to the component itself. Clearance and creepage distances to other components are to be designed in accordance with the relevant application standards.
IPC conformity	Conformity: The products are developed, manufactured and delivered according international recognized standards and norms and comply with the assured properties in the data sheet resp. fulfill decorative properties in accordance with IPC-A-610 "Class 2". Further claims on the products can be evaluated on request.

Data sheet**OMNIMATE Signal - series BL/SL 3.50
BLL 3.50/06/180 3.2SN BK TU**

Weidmüller Interface GmbH & Co. KG
Klingenbergstraße 26
D-32758 Detmold
Germany
Fon: +49 5231 14-0
Fax: +49 5231 14-292083
www.weidmueller.com

Technical data**Approvals**

Approvals



ROHS

Conform

DownloadsApproval/Certificate/Document of
Conformity[Declaration of the Manufacturer](#)

Brochure/Catalogue

[FL DRIVES EN](#)
[MB DEVICE MANUF. EN](#)
[FL DRIVES DE](#)
[CAT 2 PORTFOLIOGUIDE EN](#)
[FL BUILDING SAFETY EN](#)
[FL APPL LED LIGHTING EN](#)
[FLIndustr.CONTROLS EN](#)
[FL MACHINE SAFETY EN](#)
[FL HEATING ELECTR EN](#)
[FL APPL INVERTER EN](#)
[FL_BASE_STATION_EN](#)
[FL ELEVATOR EN](#)
[FL POWER SUPPLY EN](#)
[FL 72H SAMPLE SER EN](#)
[PO OMNIMATE EN](#)

Engineering Data

[EPLAN_WSCAD](#)

Engineering Data

[STEP](#)

Data sheet

**OMNIMATE Signal - series BL/SL 3.50
BLL 3.50/06/180 3.2SN BK TU**

Weidmüller Interface GmbH & Co. KG
 Klingenbergstraße 26
 D-32758 Detmold
 Germany
 Fon: +49 5231 14-0
 Fax: +49 5231 14-292083
 www.weidmueller.com

Drawings

Dimensional drawing

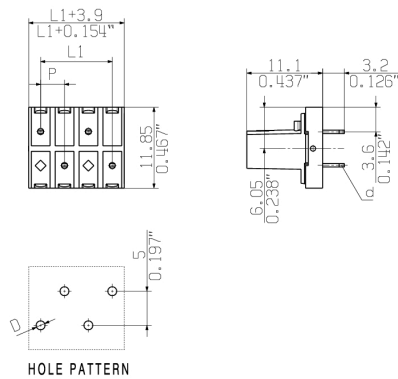

Product benefits



Connection made easy
 Safe board-to-board connection

MASSE OHNE TOLERANZ SIND KEINE PRUEFMASSE
DIMS. WITHOUT TOLERANCE ARE NOT CONTROL DIMS.

DIE DEUTSCHE VERSION IST VERBINDLICH
THE GERMAN VERSION IS BINDING

ALLGEMEINGUELTIGE KUNDENZEICHUNG, AKTUELLER STAND NUR AUF ANFRAGE
GENERAL CUSTOMER DRAWING, TOPICAL VERSION ONLY IF REQUIRED

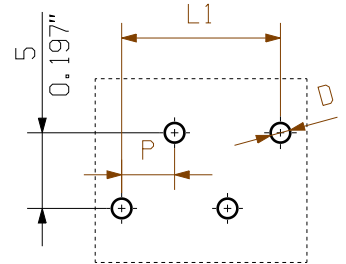
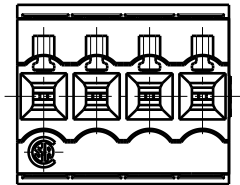
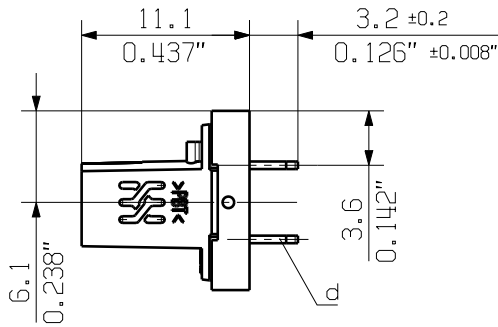
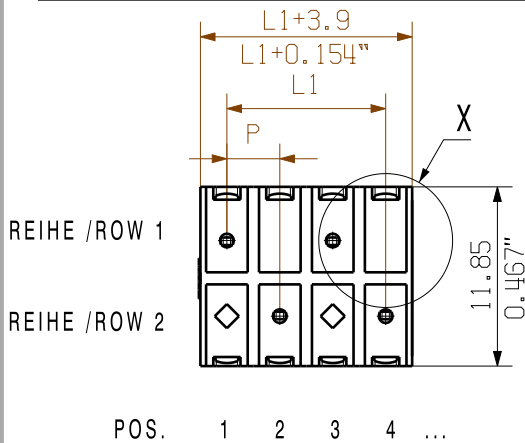

DETAIL A
X 5/1

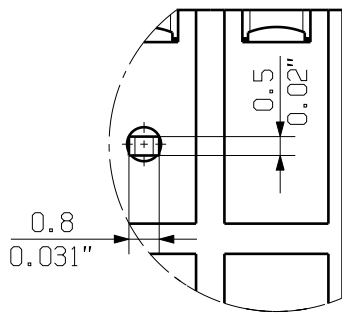

SHOWN : BLL 3.50/04/180

HOLE PATTERN

M 1/1

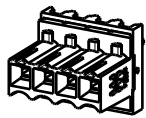

P=3.50 RASTER PITCH
D=Ø1.3 +0.1
d=0.5x0.8

For the mounting of PCBs, it should be noted that the rated data given in the catalogue relates only to the connection elements. The necessary creepage and clearance paths must be observed in connection with the respective applicant in accordance to VDE 0110. The current-carrying capacity and pitch tolerance is to be determined according to DIN IEC 326 part 3 very fine.

Weidmüller connectors are tested to the DIN VDE 0627 standard, and are valid for its field of application. Provided that the connectors are used to the intended purpose, all requirements with respect to the occurring of electrical, mechanical, thermic and corrosive stress will be satisfied.

n	POLZAHL POLES	L1 [mm]	L1 [inch]	REIHE/ ROW	1	2	3	4	5	6	7	8	9	10	11	12
12	38.5	1.516		1	X	0	X	0	X	0	X	0	X	0	X	0
				2	0	X	0	X	0	X	0	X	0	X	0	X
11	35.0	1.378		1	X	0	X	0	X	0	X	0	X	0	X	
				2	0	X	0	X	0	X	0	X	0	X	0	
10	31.5	1.240		1	X	0	X	0	X	0	X	0	X	0		
				2	0	X	0	X	0	X	0	X	0	X	0	
9	28.0	1.102		1	X	0	X	0	X	0	X	0	X			
				2	0	X	0	X	0	X	0	X	0			
8	24.5	0.965		1	X	0	X	0	X	0	X	0				
				2	0	X	0	X	0	X	0	X				
7	21.0	0.827		1	X	0	X	0	X	0	X					
				2	0	X	0	X	0	X	0					
6	17.5	0.689		1	X	0	X	0	X	0						
				2	0	X	0	X	0	X						
5	14.0	0.551		1	X	0	X	0	X							
				2	0	X	0	X	0							
4	10.5	0.413		1	X	0	X	0								
				2	0	X	0	X								
3	7.0	0.276		1	X	0	X									
				2	0	X	0									
2	3.5	0.138		1	X	0										
				2	0	X										

GENERAL TOLERANCE:
DIN ISO 2768-m



80439/5
17.02.15 HELIS_MA 01
MODIFICATION

Weidmüller

CAT.NO.:
C 33133 14

DRAWING NO. SHEET 01 OF 01 SHEETS
ISSUE NO.



DATE NAME
DRAWN 22.04.2005 FROEHLKING_M

RESPONSIBLE CHECKED 17.02.2015 LANG_T
HELIIS_MA

SCALE: 2/1

APPROVED LANG_T

BLL 3.50/.../180...
BUCHSENLEISTE
FEMALE HEADER

SUPERSEDES: .

PRODUCT FILE: BLL 3.50

7369

WEITERGABE SOWIE Vervielfaeltigung dieses Dokuments, Verwertung und Mitteilung seines Inhalts sind verboten, soweit nicht ausdruecklich gestattet. ZUWIDERHANDLUNGEN VERPFLICHTEN ZU SCHADENERSATZ. ALLE RECHTE FUER DEN FALL DER PATENT-, GEBRAUCHSMUSTER- ODER GESCHMACKSMUSTERREINTRAGUNG VORBEHALTEN. THE REPRODUCTION, DISTRIBUTION AND UTILIZATION OF THIS DOCUMENT AS WELL AS THE COMMUNICATION OF ITS CONTENTS TO OTHERS WITHOUT EXPLICIT AUTHORIZATION IS PROHIBITED. OFFENDERS WILL BE HELD LIABLE FOR THE PAYMENT OF DAMAGES. WEIDMUELLER EXCLUSIVELY RESERVES THE RIGHT TO FILE FOR PATENTS, UTILITY MODELS OR DESIGNS. WEIDMUELLER INTERFACE GmbH & Co.KG

Recommended wave soldering profiles

Weidmüller Interface GmbH & Co. KG
 Klängenbergstraße 16
 D-32758 Detmold
 Germany
 Fon: +49 5231 14-0
 Fax: +49 5231 14-292083
 www.weidmueller.com

Single Wave:



Double Wave:



Wave soldering profiles

Wired connection elements should be processed in accordance with the DIN EN 61760-1 standard. We have included two recommendations for practical wave soldering profiles, with which Weidmüller PCB terminals and connectors are qualified.

When choosing a suitable profile for your application, the following factors also need to be considered:

- PCB thickness
- Proportion of Cu in the layers
- Single/double-sided assembly
- Product range
- Heating and cooling rates

The single and double wave profiles each indicate the recommended operating range, including the maximum soldering temperature of 260°C. In practice, the maximum soldering temperature is quite often well below the above maximum profile.