

OMNIMATE Power - series BU/SU 10.16HP SU 10.16HP/05/90MF4 3.5AG BK BX

Weidmüller Interface GmbH & Co. KG
Klingenbergstraße 26
D-32758 Detmold
Germany
Fon: +49 5231 14-0
Fax: +49 5231 14-292083
www.weidmueller.com

Product image



Similar to illustration

Single-row, high-current male header, for side-by-side mounting without sacrificing any poles, or with patented flange for fast locking without tools. Maximum connection and operating reliability thanks to a mating profile that prevents incorrect connection, with unique coding diversity and additional fastening in the flange. 3.5 mm pin length is optimised for wave soldering, plug-in direction 90° to solder pins.

General ordering data

Type	SU 10.16HP/05/90MF4 3.5AG BK BX
Order No.	2597240000
Version	PCB plug-in connector, male header, closed side, Middle flange, THT solder connection, 10.16 mm, Number of poles: 5, 90°, Solder pin length (l): 3.5 mm, black, Box
GTIN (EAN)	4050118609400
Qty.	30 pc(s).
Product data	IEC: 1000 V / 78.3 A UL: 300 V / 60 A
Packaging	Box

Creation date May 2, 2020 1:12:54 AM CEST

**OMNIMATE Power - series BU/SU 10.16HP
SU 10.16HP/05/90MF4 3.5AG BK BX**

Weidmüller Interface GmbH & Co. KG
Klingenbergstraße 26
D-32758 Detmold
Germany
Fon: +49 5231 14-0
Fax: +49 5231 14-292083
www.weidmueller.com

Technical data**Dimensions and weights**

Net weight	21.41 g
------------	---------

System specifications

Product family	OMNIMATE Power - series BU/SU 10.16HP	Type of connection	Board connection
Mounting onto the PCB	THT solder connection	Pitch in mm (P)	10.16 mm
Pitch in inches (P)	0.4 inch	Outgoing elbow	90°
Number of poles	5	Number of solder pins per pole	3
Solder pin length (l)	3.5 mm	Solder pin length tolerance	+0.1 / -0.3 mm
Solder pin dimensions	1.2 x 1.1 mm	Solder pin dimensions = d tolerance	+0.1 / -0.1 mm
Solder eyelet hole diameter (D)	1.6 mm	Solder eyelet hole diameter tolerance (D)	+ 0,1 mm
L1 in mm	50.8 mm	L1 in inches	2 inch
Pin series quantity	2	Touch-safe protection acc. to DIN VDE 57 106	Safe from finger touch, plugged
Touch-safe protection acc. to DIN VDE 0470	IP20 plugged	Volume resistance	2.00 mΩ
Can be coded	Yes	Plugging cycles	≤ 50

Material data

Insulating material	PBT GF	Colour	black
Colour chart (similar)	RAL 9011	Insulating material group	IIIa
Comparative Tracking Index (CTI)	≥ 200	Insulation strength	≥ 10 ⁸ Ω
UL 94 flammability rating	V-0	GWFI	960 °C
Contact material	Copper alloy	Layer structure of solder connection	3- μm Ag
Layer structure of plug contact	3- μm Ag	Storage temperature, min.	-25 °C
Storage temperature, max.	50 °C	Max. relative humidity during storage	70 %
Operating temperature, min.	-50 °C	Operating temperature, max.	120 °C
Temperature range, installation, min.	-25 °C	Temperature range, installation, max.	120 °C

Rated data acc. to IEC

tested acc. to standard	IEC 60664-1, IEC 61984	Rated current, min. number of poles (Tu=20°C)	78.3 A
Rated current, max. number of poles (Tu=20°C)	67.9 A	Rated current, min. number of poles (Tu=40°C)	70.6 A
Rated current, max. number of poles (Tu=40°C)	61.3 A	Rated voltage for surge voltage class / pollution degree II/2	1,000 V
Rated voltage for surge voltage class / pollution degree III/2	1,000 V	Rated voltage for surge voltage class / pollution degree III/3	690 V
Rated impulse voltage for surge voltage class/ pollution degree II/2	6 kV	Rated impulse voltage for surge voltage class/ pollution degree III/2	8 kV
Rated impulse voltage for surge voltage class/ contamination degree III/3	8 kV	Short-time withstand current resistance	3 x 1s mit 1000 A
Clearance, min.	8.9 mm	Creepage distance, min.	10.5 mm

Rated data acc. to CSA

Rated voltage (Use group B / CSA)	300 V	Rated voltage (Use group C / CSA)	300 V
Rated voltage (Use group D / CSA)	600 V	Rated current (Use group B / CSA)	60 A
Rated current (Use group C / CSA)	60 A	Rated current (Use group D / CSA)	5 A

Creation date May 2, 2020 1:12:54 AM CEST

Catalogue status 17.04.2020 / We reserve the right to make technical changes.

2

**OMNIMATE Power - series BU/SU 10.16HP
SU 10.16HP/05/90MF4 3.5AG BK BX**

Weidmüller Interface GmbH & Co. KG
Klingenbergstraße 26
D-32758 Detmold
Germany
Fon: +49 5231 14-0
Fax: +49 5231 14-292083
www.weidmueller.com

Technical data
Rated data acc. to UL 1059

Rated voltage (Use group B / UL 1059)	300 V	Rated voltage (Use group C / UL 1059)	300 V
Rated voltage (Use group D / UL 1059)	600 V	Rated current (Use group B / UL 1059)	60 A
Rated current (Use group C / UL 1059)	60 A	Rated current (Use group D / UL 1059)	5 A
Clearance distance, min.	8.9 mm	Creepage distance, min.	10.5 mm

Packing

Packaging	Box	VPE length	0
VPE width	0	VPE height	0

Classifications

ETIM 6.0	EC002637	ETIM 7.0	EC002637
eClass 9.0	27-44-04-02	eClass 9.1	27-44-04-02
eClass 10.0	27-44-04-02		

Notes

Notes	<ul style="list-style-type: none"> • Additional colours on request • Rated current related to rated cross-section & min. No. of poles. • Wire end ferrule with plastic collar to DIN 46228/4 • Wire end ferrule without plastic collar to DIN 46228/1 • P on drawing = pitch • Rated data refer only to the component itself. Clearance and creepage distances to other components are to be designed in accordance with the relevant application standards. • MFX and MSFX: X= Position of the middle flange e.g. MF2, MSF3 • For all applications with flange we recommend to fix the pin header with the help of the soldering flange or a self-tapping screw on the board.
-------	--

IPC conformity	Conformity: The products are developed, manufactured and delivered according international recognized standards and norms and comply with the assured properties in the data sheet resp. fulfill decorative properties in accordance with IPC-A-610 "Class 2". Further claims on the products can be evaluated on request.
----------------	--

Downloads

White paper power electronics connected correctly	Download Whitepaper
White paper UL 600 V	Download Whitepaper

**OMNIMATE Power - series BU/SU 10.16HP
SU 10.16HP/05/90MF4 3.5AG BK BX**

Weidmüller Interface GmbH & Co. KG
Klingenbergstraße 26
D-32758 Detmold
Germany
Fon: +49 5231 14-0
Fax: +49 5231 14-292083
www.weidmueller.com

Drawings

Dimensional drawing

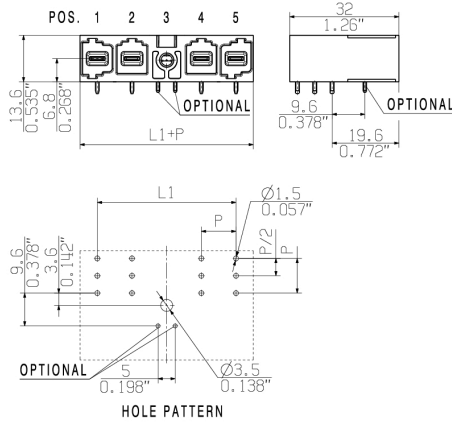

Graph

6	M(S)F6	o	o	o	o	o	X	o
6	M(S)F5	o	o	o	o	o	X	o
6	M(S)F4	o	o	o	X	o	o	o
6	M(S)F3	o	o	X	o	o	o	o
6	M(S)F2	o	X	o	o	o	o	o
5	M(S)F5	o	o	o	o	X	o	o
5	M(S)F4	o	o	o	X	o	o	o
5	M(S)F3	o	o	X	o	o	o	o
5	M(S)F2	o	X	o	o	o	o	o
4	M(S)F4	o	o	o	X	o	o	o
4	M(S)F3	o	o	X	o	o	o	o
4	M(S)F2	o	X	o	o	o	o	o
3	M(S)F3	o	o	X	o	o	o	o
3	M(S)F2	o	X	o	o	o	o	o
2	M(S)F2	o	X	o	o	o	o	o
No of poles	X = middle flange position	1	2	3	4	5	6	7

Example of use

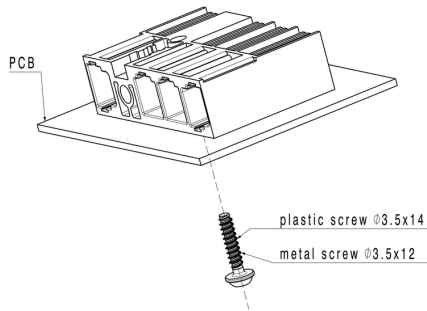

**OMNIMATE Power - series BU/SU 10.16HP
SU 10.16HP/05/90MF4 3.5AG BK BX**

Weidmüller Interface GmbH & Co. KG
 Klingenbergstraße 26
 D-32758 Detmold
 Germany
 Fon: +49 5231 14-0
 Fax: +49 5231 14-292083
 www.weidmueller.com

Mating connector (conditionally pluggable)
BUF 10.16IT 180MSF AG

Device connectivity | OMNIMATE® Power BUF 10.16
 PUSH IN PCB connector, 16mm², with wire-ready
 function

- PUSH IN technology with settable wire-ready contact point simplifies the connection of stranded wires without wire-end ferrules and wires with particularly rigid insulation
- Direct and tool-free connection of solid wires and wires with crimped wire-end ferrules for fast and safe wiring
- Single-hand operation of the plug-in connector and automatic connection thanks to the middle flange with snap-on mechanism and optionally with additional screw fastening

General ordering data

Type	BUF 10.16IT/05/180MSF4 ...	Version	Product data	Packaging
Order No.	2586750000	PCB plug-in connector, female plug, 10.16 mm, Number of poles: 5,	IEC: 1000 V / 76 A / 2.5 - 16 mm ²	Box
GTIN (EAN)	4050118596168	180°, PUSH IN with actuator, Clamping range, max. : 16 mm ² , Box	UL: 600 V / 34 A / AWG 12 - AWG 6	
Qty.	50 pc(s).			

**OMNIMATE Power - series BU/SU 10.16HP
SU 10.16HP/05/90MF4 3.5AG BK BX**

Weidmüller Interface GmbH & Co. KG
Klingenbergstraße 26
D-32758 Detmold
Germany
Fon: +49 5231 14-0
Fax: +49 5231 14-292083
www.weidmueller.com

Mating connector (fully pluggable)
BUF 10.16IT 180MF AG

Device connectivity | OMNIMATE® Power BUF 10.16
PUSH IN PCB connector, 16mm², with wire-ready
function

- PUSH IN technology with settable wire-ready contact point simplifies the connection of stranded wires without wire-end ferrules and wires with particularly rigid insulation
- Direct and tool-free connection of solid wires and wires with crimped wire-end ferrules for fast and safe wiring
- Single-hand operation of the plug-in connector and automatic connection thanks to the middle flange with snap-on mechanism and optionally with additional screw fastening

General ordering data

Type	BUF 10.16IT/05/180MF4 A ...	Version	Product data	Packaging
Order No.	2586710000	PCB plug-in connector, female plug, 10.16 mm, Number of poles: 5,	IEC: 1000 V / 76 A / 2.5 - 16 mm ²	Box
GTIN (EAN)	4050118596120	180°, PUSH IN with actuator, Clamping range, max. : 16 mm ² , Box	UL: 600 V / 34 A / AWG 12 - AWG 6	
Qty.	50 pc(s).			

Recommended wave soldering profiles

Weidmüller Interface GmbH & Co. KG
 Klängenbergstraße 16
 D-32758 Detmold
 Germany
 Fon: +49 5231 14-0
 Fax: +49 5231 14-292083
 www.weidmueller.com

Single Wave:



Double Wave:



Wave soldering profiles

Wired connection elements should be processed in accordance with the DIN EN 61760-1 standard. We have included two recommendations for practical wave soldering profiles, with which Weidmüller PCB terminals and connectors are qualified.

When choosing a suitable profile for your application, the following factors also need to be considered:

- PCB thickness
- Proportion of Cu in the layers
- Single/double-sided assembly
- Product range
- Heating and cooling rates

The single and double wave profiles each indicate the recommended operating range, including the maximum soldering temperature of 260°C. In practice, the maximum soldering temperature is quite often well below the above maximum profile.