

SAIE-M8S-3S-F9THR**Weidmüller Interface GmbH & Co. KG**

Klingenbergstraße 26

D-32758 Detmold

Germany

Fon: +49 5231 14-0

Fax: +49 5231 14-292083

www.weidmueller.com

Similar to illustration

Weidmüller is one of the industry's leading international providers of connectors. An important mainstay in this product family are the circular connectors, which Weidmüller groups under the product name SAI. In the development of SAI products, Weidmüller engineers have always concentrated on achieving rational, cost-effective installation concepts, and – in cooperation with major users – have supplied the markets with well-conceived products which set standards in terms of functionality and quality across the globe. The best examples are the new power distributors with S and T coded M12. These modules are characterised by particularly high currents and voltages. This enables them to also be used, for example, with three-phase motors.

General ordering data

Type	SAIE-M8S-3S-F9THR
Order No.	2422920000
Version	Built-in plugs, M8, Number of poles: 3, Front mounting
GTIN (EAN)	4050118430110
Qty.	25 pc(s).

Creation date May 2, 2020 6:30:43 PM CEST

Catalogue status 17.04.2020 / We reserve the right to make technical changes.

SAIE-M8S-3S-F9THR

Weidmüller Interface GmbH & Co. KG

Klingenbergstraße 26

D-32758 Detmold

Germany

Fon: +49 5231 14-0

Fax: +49 5231 14-292083

www.weidmueller.com

Technical data

Dimensions and weights

Net weight 7.84 g

Environmental Product Compliance

REACH SVHC Lead 7439-92-1

Technical data of PCB plug-in connector

Coding	M8 = none	Housing surface	nickel-plated
Housings	M8 pin	Mounting height	9 mm
Mounting thread	M10	Number of poles	3
Shield connection	Yes	Type of mounting	Front mounting
Rated voltage	60 V	Rated voltage (text)	60 V (3-pole) / 30 V (4-, 5- and 8-pole)
Rated current	4 A	Rated current	4 A (3-, 4- and 5-pole) / 1.5 A (8-pole)
Temperature range	-30...80 °C	Protection degree	IP67
Contact surface	Au (Gold)	Housing main material	CuZn, nickel-plated
Connection thread	M8	Tightening torque	M8: 0.5 Nm
Mounting thread	M10	Mounting torque range	0.8 Nm
Mounting onto the PCB	THT/THR solder connection	Insulation strength	100 MΩ
Pollution severity	3 (2 within the sealed area)	Plugging cycles	≥ 100
Contact material	CuZn	Seal material	NBR
Lock nut material	Nickel-plated CuZn	Material of the flange-mounted housing	Nickel-plated CuZn
Grouting material	PUR		

Material data

Contact material CuZn Contact surface Au (Gold)

System parameters

Mounting onto the PCB	THT/THR solder connection	Insulation strength	100 MΩ
Number of poles	3	Pin series quantity	1
Plugging cycles	≥ 100	Protection degree	IP67

Classifications

ETIM 6.0	EC002638	ETIM 7.0	EC002638
eClass 9.0	27-44-03-09	eClass 9.1	27-44-03-09
eClass 10.0	27-44-03-09		

Approvals

ROHS Conform

Downloads

Brochure/Catalogue [FL FIELDWIRING EN](#)
Engineering Data [STEP](#)

Creation date May 2, 2020 6:30:43 PM CEST

Catalogue status 17.04.2020 / We reserve the right to make technical changes.

SAIE-M8S-3S-F9THR

Weidmüller Interface GmbH & Co. KG
 Klingenbergstraße 26
 D-32758 Detmold
 Germany
 Fon: +49 5231 14-0
 Fax: +49 5231 14-292083
 www.weidmueller.com

Drawings

Dimensioned drawing

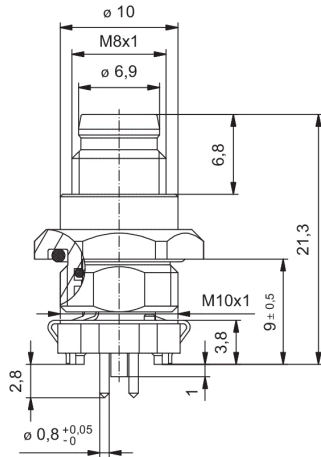

PCB design

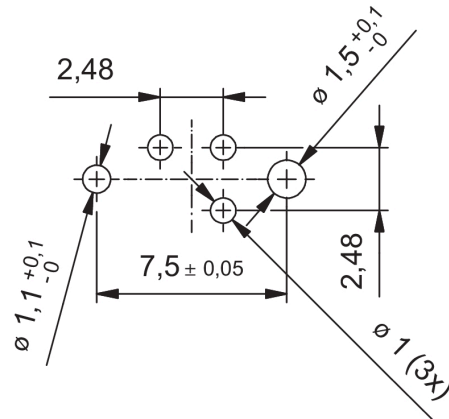

Pole scheme

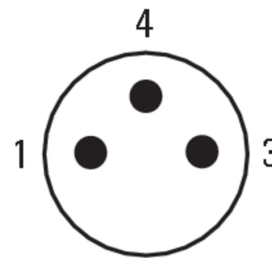

Recommended wave soldering profiles

Weidmüller Interface GmbH & Co. KG
 Klängenbergstraße 16
 D-32758 Detmold
 Germany
 Fon: +49 5231 14-0
 Fax: +49 5231 14-292083
 www.weidmueller.com

Single Wave:



Double Wave:

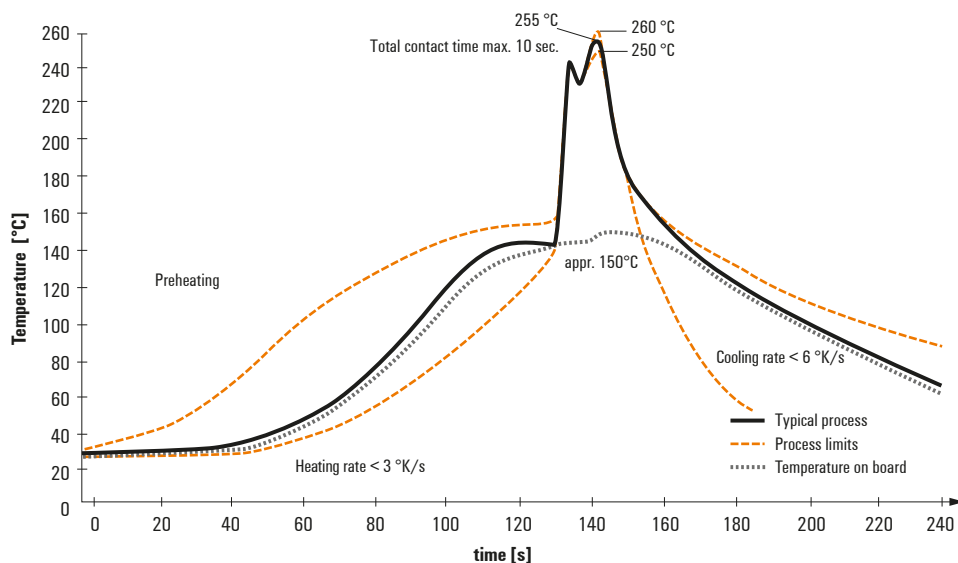

Wave soldering profiles

Wired connection elements should be processed in accordance with the DIN EN 61760-1 standard. We have included two recommendations for practical wave soldering profiles, with which Weidmüller PCB terminals and connectors are qualified.

When choosing a suitable profile for your application, the following factors also need to be considered:

- PCB thickness
- Proportion of Cu in the layers
- Single/double-sided assembly
- Product range
- Heating and cooling rates

The single and double wave profiles each indicate the recommended operating range, including the maximum soldering temperature of 260°C. In practice, the maximum soldering temperature is quite often well below the above maximum profile.

Recommended reflow soldering profile

Weidmüller Interface GmbH & Co. KG
 Klingenbergstraße 16
 D-32758 Detmold
 Germany
 Fon: +49 5231 14-0
 Fax: +49 5231 14-292083
 www.weidmueller.com

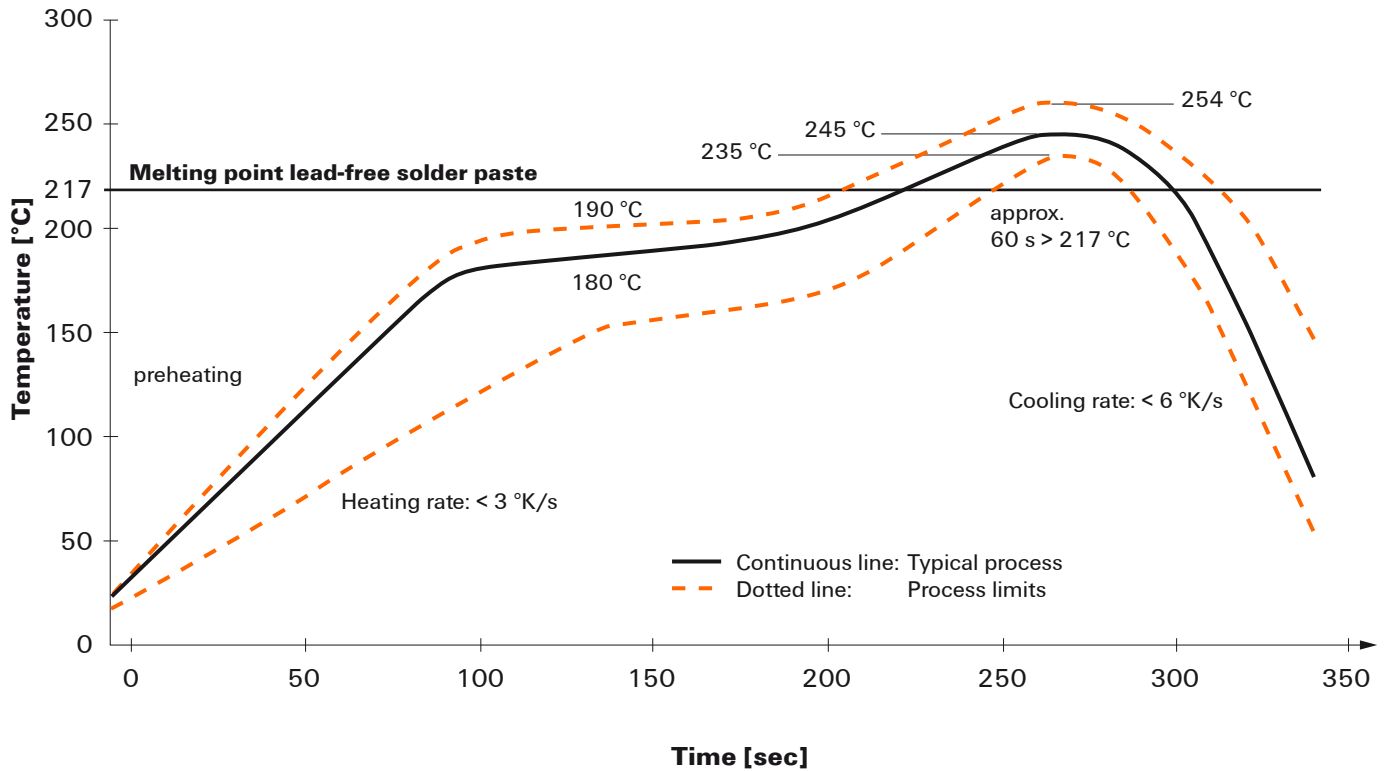

Reflow soldering profile

The perfect soldering profile for SMT Surface Mount Technology is one the most exiting question in SMT production. But there are more than one correct answer: The diagram of temperature-on-time is related to processing features of solder paste and to maximum load of components.

We have to consider the following parameters:

- Time for pre heating
- Maximum temperature
- Time above melting point
- Time for cooling
- Maximum heating rate
- Maximum cooling rate

We recommend a typical solder profile with associated process limits. With preheating components and board are prepared smoothly for the solder phase. Heating rate is typically $\leq +3\text{K/s}$. In parallel the solder paste is ‚activated‘. The time above melting point of 217°C the paste gets liquid and components and boards begin to connect. The maximum temperature of 245°C to 254°C should stay between 10 and 40 seconds. In the cooling phase at $\geq -6\text{K/s}$ solder is cured. Board and components cool down while avoiding cold cracks.