

SAIE-M12B-4S-9SMT**Weidmüller Interface GmbH & Co. KG**

Klingenbergstraße 26

D-32758 Detmold

Germany

Fon: +49 5231 14-0

Fax: +49 5231 14-292083

www.weidmueller.com



Weidmüller is one of the industry's leading international providers of connectors. An important mainstay in this product family are the circular connectors, which Weidmüller groups under the product name SAI. In the development of SAI products, Weidmüller engineers have always concentrated on achieving rational, cost-effective installation concepts, and – in cooperation with major users – have supplied the markets with well-conceived products which set standards in terms of functionality and quality across the globe. The best examples are the new power distributors with S and T coded M12. These modules are characterised by particularly high currents and voltages. This enables them to also be used, for example, with three-phase motors.

General ordering data

Type	SAIE-M12B-4S-9SMT
Order No.	2422360000
Version	Built-in plugs, M12, Number of poles: 4
GTIN (EAN)	4050118430882
Qty.	25 pc(s).

Creation date May 2, 2020 6:45:07 PM CEST

SAIE-M12B-4S-9SMT

Weidmüller Interface GmbH & Co. KG

Klingenbergstraße 26

D-32758 Detmold

Germany

Fon: +49 5231 14-0

Fax: +49 5231 14-292083

www.weidmueller.com

Technical data

Dimensions and weights

Net weight 9.36 g

Environmental Product Compliance

REACH SVHC Lead 7439-92-1

Technical data of PCB plug-in connector

Coding	A	Housing surface	nickel-plated
Housings	M12 socket	Mounting height	9 mm
Mounting thread	M14	Number of poles	4
Shield connection	Yes	Rated voltage	250 V
Rated voltage (text)	250 V (4-pole) / 60 V (5-pole) / 30 V (8-pole)	Rated current	4 A
Rated current	4 A (4- and 5-pole) / 2 A (8-pole)	Temperature range	-30...80 °C
Protection degree	IP67	Contact surface	Au (Gold)
Housing main material	CuZn, nickel-plated	Connection thread	M12
Tightening torque	M12: 0.8 Nm	Mounting thread	M 14
Mounting torque range	1.2 Nm	Mounting onto the PCB	SMD solder connection
Insulation strength	100 MΩ	Pollution severity	3 (2 within the sealed area)
Plugging cycles	≥ 100	Contact material	CuZn
Lock nut material	Nickel-plated CuZn	Material of the flange-mounted housing	Nickel-plated CuZn

Material data

Contact material CuZn Contact surface Au (Gold)

System parameters

Mounting onto the PCB	SMD solder connection	Insulation strength	100 MΩ
Number of poles	4	Pin series quantity	1
Plugging cycles	≥ 100	Protection degree	IP67

Classifications

ETIM 6.0	EC002638	ETIM 7.0	EC002638
eClass 9.0	27-44-03-09	eClass 9.1	27-44-03-09
eClass 10.0	27-44-03-09		

Approvals

ROHS Conform

Downloads

Brochure/Catalogue [FL FIELDWIRING EN](#)
Engineering Data [STEP](#)

SAIE-M12B-4S-9SMT

Weidmüller Interface GmbH & Co. KG
 Klingenbergstraße 26
 D-32758 Detmold
 Germany
 Fon: +49 5231 14-0
 Fax: +49 5231 14-292083
 www.weidmueller.com

Drawings

Dimensioned drawing

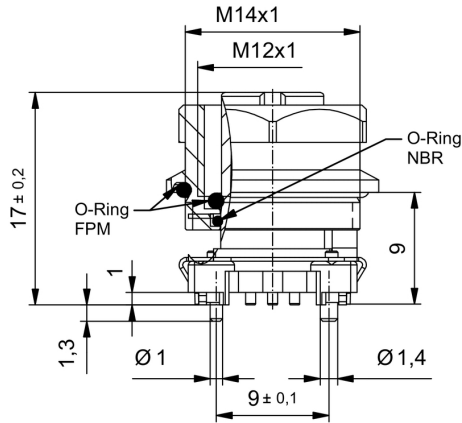

Pole scheme

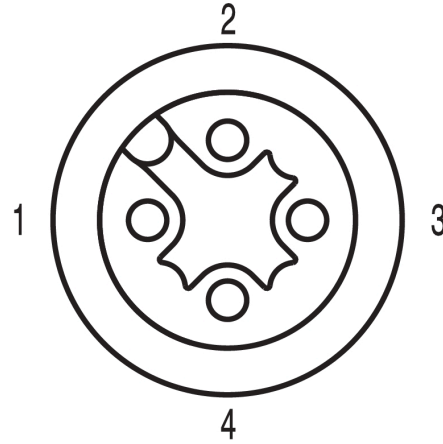

PCB design

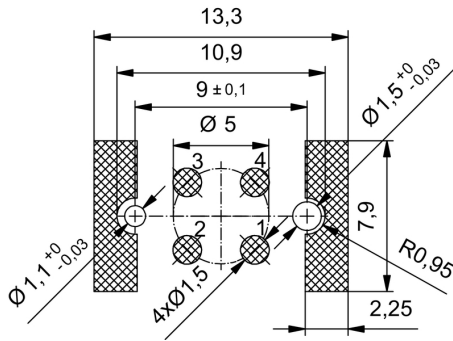

Recommended reflow soldering profile

Weidmüller Interface GmbH & Co. KG
 Klingenbergstraße 16
 D-32758 Detmold
 Germany
 Fon: +49 5231 14-0
 Fax: +49 5231 14-292083
 www.weidmueller.com



Reflow soldering profile

The perfect soldering profile for SMT Surface Mount Technology is one the most exiting question in SMT production. But there are more than one correct answer: The diagram of temperature-on-time is related to processing features of solder paste and to maximum load of components.

We have to consider the following parameters:

- Time for pre heating
- Maximum temperature
- Time above melting point
- Time for cooling
- Maximum heating rate
- Maximum cooling rate

We recommend a typical solder profile with associated process limits. With preheating components and board are prepared smoothly for the solder phase. Heating rate is typically $\leq +3\text{K/s}$. In parallel the solder paste is ‚activated‘. The time above melting point of 217°C the paste gets liquid and components and boards begin to connect. The maximum temperature of 245°C to 254°C should stay between 10 and 40 seconds. In the cooling phase at $\geq -6\text{K/s}$ solder is cured. Board and components cool down while avoiding cold cracks.