

OMNIMATE Housing - series CH20M6 SR-SMD 4.50/05/90 AU BK BX

Weidmüller Interface GmbH & Co. KG
Klingenbergstraße 26
D-32758 Detmold
Germany
Fon: +49 5231 14-0
Fax: +49 5231 14-292083
www.weidmueller.com



The integrated rail bus for the modular electronics housing system

When supplying, connecting or distributing within modular applications, the rail bus can replace the tedious individual wiring process with a flexible and uninterrupted system-wide solution.

The system bus is securely integrated within the 35-mm standard mounting rail. The SMD-bus contact block can be reflow-soldered so that it can be completely automatically processed during the component assembly.

The resistant, gold-plated contact surfaces ensure a permanent and reliable contact for all housing widths.

- **Unlimited scalability** The integrated connection solution covers all system widths: from the 6-mm slice to the 67-mm large-area housing.
- **Easy to service during installation** It's easy to replace a module, even in existing modules groups – without any influence on the neighbouring modules.
- **Universal integration** The uninterrupted system bus is securely integrated within the 35-mm standard mounting rail.
- **Maximum availability** Five fully-galvanized and partially gold-plated twin-arched contacts are used to establish a permanent contact to the rail bus. THR solder flanges ensure that the connection to the circuit board is stable.

General ordering data

Type	SR-SMD 4.50/05/90 AU BK BX
Order No.	1155840000
Version	PCB plug-in connector, Bus-contact block for CH20M6, THT/THR solder connection, Number of poles: 5, 180°, Gold-plated, black
GTIN (EAN)	4032248942534
Qty.	78 pc(s).
Product data	UL:
Packaging	Box

**OMNIMATE Housing - series CH20M6
SR-SMD 4.50/05/90 AU BK BX**

Weidmüller Interface GmbH & Co. KG
 Klingenbergstraße 26
 D-32758 Detmold
 Germany
 Fon: +49 5231 14-0
 Fax: +49 5231 14-292083
 www.weidmueller.com

Technical data**Dimensions and weights**

Length	24 mm	Length (inches)	0.945 inch
Width	16.3 mm	Width (inches)	0.642 inch
Height	5.9 mm	Height (inches)	0.232 inch
Net weight	2.936 g		

System specifications

Product family	OMNIMATE Housing - series CH20M6	Type of connection	Board connection
Mounting onto the PCB	THT/THR solder connection	Pitch in mm (P)	5 mm
Pitch in inches (P)	0.197 inch	Outgoing elbow	180°
Number of poles	5	Solder pin length tolerance	+0.1 / -0.2 mm
L1 in mm	20 mm	L1 in inches	0.787 inch
Pin series quantity	1	Volume resistance	≤ 5mΩ
Plugging cycles	25		

Material data

Insulating material	LCP	Colour	black
Colour chart (similar)	RAL 9011	Insulating material group	IIIa
Comparative Tracking Index (CTI)	≥ 175	Insulation strength	≥ 10 ⁸ Ω
Moisture Level (MSL)	1	Contact surface	Gold-plated
Storage temperature, min.	-25 °C	Storage temperature, max.	50 °C
Max. relative humidity during storage	70 %	Operating temperature, min.	-50 °C
Operating temperature, max.	100 °C	Temperature range, installation, min.	-30 °C
Temperature range, installation, max.	100 °C		

Rated data acc. to IEC

tested acc. to standard	IEC 60664-1, IEC 61984
-------------------------	------------------------

Classifications

ETIM 6.0	EC001031	ETIM 7.0	EC001031
eClass 9.0	27-18-27-90	eClass 9.1	27-18-27-90
eClass 10.0	27-18-27-92		

Notes

IPC conformity	Conformity: The products are developed, manufactured and delivered according international recognized standards and norms and comply with the assured properties in the data sheet resp. fulfill decorative properties in accordance with IPC-A-610 "Class 2". Further claims on the products can be evaluated on request.
----------------	--

Approvals

Approvals



ROHS	Conform
------	---------

Data sheet**OMNIMATE Housing - series CH20M6
SR-SMD 4.50/05/90 AU BK BX**

Weidmüller Interface GmbH & Co. KG
Klingenbergstraße 26
D-32758 Detmold
Germany
Fon: +49 5231 14-0
Fax: +49 5231 14-292083
www.weidmueller.com

Technical data**Downloads**

Brochure/Catalogue	FL ANALO.SIGN.CONV. EN MB DEVICE MANUF. EN CAT 2 PORTFOLIOGUIDE EN FL MACHINE SAFETY EN FL 72H SAMPLE SER EN PO OMNIMATE EN
Engineering Data	EPLAN
Engineering Data	STEP

**OMNIMATE Housing - series CH20M6
SR-SMD 4.50/05/90 AU BK BX**

Weidmüller Interface GmbH & Co. KG
 Klingenbergstraße 26
 D-32758 Detmold
 Germany
 Fon: +49 5231 14-0
 Fax: +49 5231 14-292083
 www.weidmueller.com

Drawings

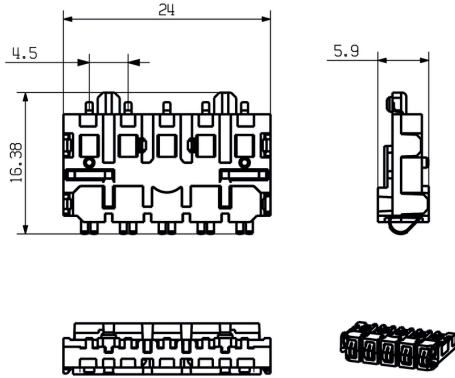

CH20M6-Bus

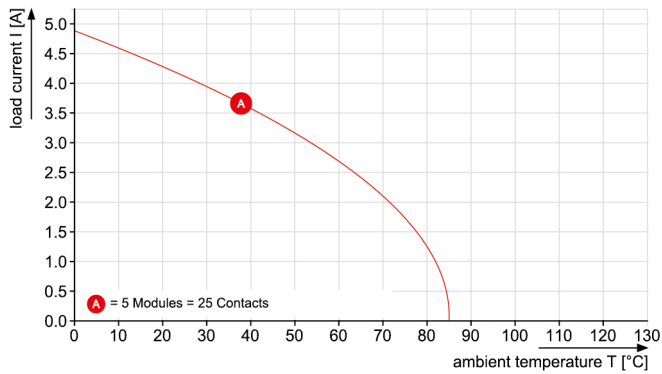

Recommended reflow soldering profile

Weidmüller Interface GmbH & Co. KG
 Klingenbergstraße 16
 D-32758 Detmold
 Germany
 Fon: +49 5231 14-0
 Fax: +49 5231 14-292083
 www.weidmueller.com

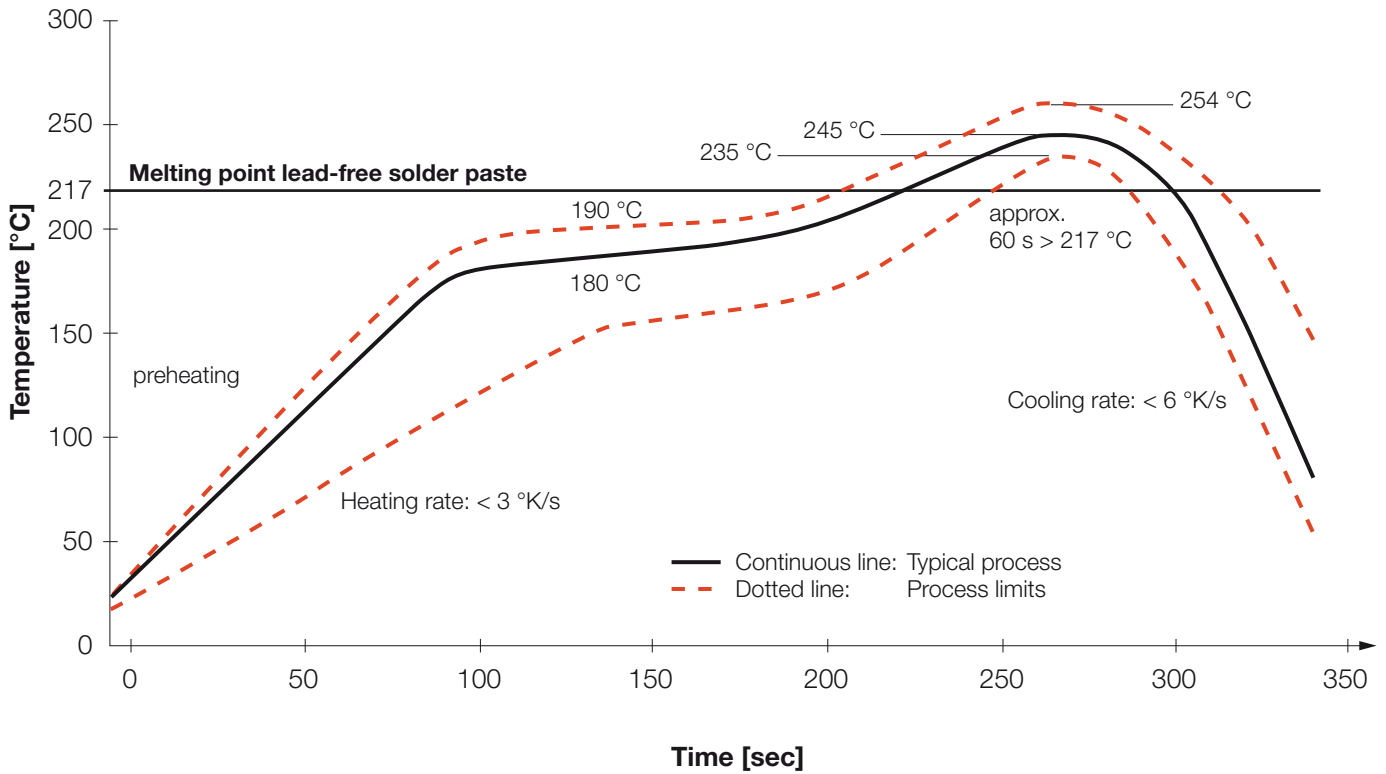

Reflow soldering profile

The perfect soldering profile for SMT Surface Mount Technology is one the most exiting question in SMT production. But there are more than one correct answer: The diagram of temperature-on-time is related to processing features of solder paste and to maximum load of components.

We have to consider the following parameters:

- Time for pre heating
- Maximum temperature
- Time above melting point
- Time for cooling
- Maximum heating rate
- Maximum cooling rate

We recommend a typical solder profile with associated process limits. With preheating components and board are prepared smoothly for the solder phase. Heating rate is typically $\leq +3\text{K/s}$. In parallel the solder paste is 'activated'. The time above melting point of 217°C the paste gets liquid and components and boards begin to connect. The maximum temperature of 245°C to 254°C should stay between 10 and 40 seconds. In the cooling phase at $\geq -6\text{K/s}$ solder is cured. Board and components cool down while avoiding cold cracks.

Recommended wave soldering profiles

Weidmüller Interface GmbH & Co. KG
 Klängenbergstraße 16
 D-32758 Detmold
 Germany
 Fon: +49 5231 14-0
 Fax: +49 5231 14-292083
 www.weidmueller.com

Single Wave:



Double Wave:



Wave soldering profiles

Wired connection elements should be processed in accordance with the DIN EN 61760-1 standard. We have included two recommendations for practical wave soldering profiles, with which Weidmüller PCB terminals and connectors are qualified.

When choosing a suitable profile for your application, the following factors also need to be considered:

- PCB thickness
- Proportion of Cu in the layers
- Single/double-sided assembly
- Product range
- Heating and cooling rates

The single and double wave profiles each indicate the recommended operating range, including the maximum soldering temperature of 260°C. In practice, the maximum soldering temperature is quite often well below the above maximum profile.

Recommended reflow soldering profile

Weidmüller Interface GmbH & Co. KG
 Klingenbergstraße 16
 D-32758 Detmold
 Germany
 Fon: +49 5231 14-0
 Fax: +49 5231 14-292083
 www.weidmueller.com



Reflow soldering profile

The perfect soldering profile for SMT Surface Mount Technology is one the most exiting question in SMT production. But there are more than one correct answer: The diagram of temperature-on-time is related to processing features of solder paste and to maximum load of components.

We have to consider the following parameters:

- Time for pre heating
- Maximum temperature
- Time above melting point
- Time for cooling
- Maximum heating rate
- Maximum cooling rate

We recommend a typical solder profile with associated process limits. With preheating components and board are prepared smoothly for the solder phase. Heating rate is typically $\leq +3\text{K/s}$. In parallel the solder paste is ‚activated‘. The time above melting point of 217°C the paste gets liquid and components and boards begin to connect. The maximum temperature of 245°C to 254°C should stay between 10 and 40 seconds. In the cooling phase at $\geq -6\text{K/s}$ solder is cured. Board and components cool down while avoiding cold cracks.