

**Data sheet | Item number: 216-266**

Ferrule; Sleeve for 2.5 mm<sup>2</sup> / AWG 14; insulated; electro-tin plated;  
electrolytic copper; gastight crimped; acc. to DIN 46228, Part 4/09.90; blue

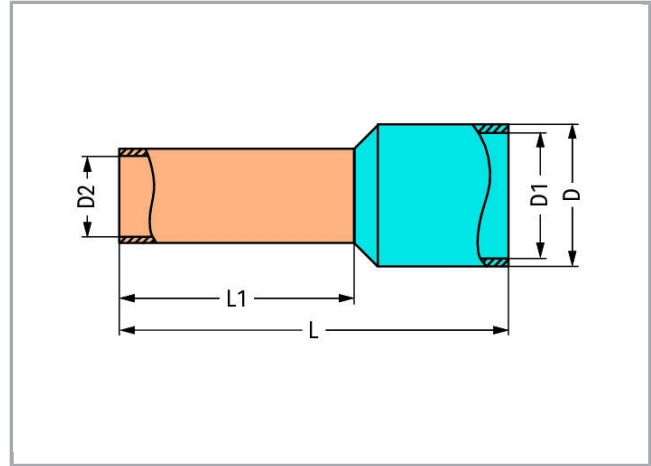

[www.wago.com/216-266](http://www.wago.com/216-266)



Subject to changes. Please also observe the further product documentation!

WAGO Kontakttechnik GmbH & Co. KG  
Hansastr. 27  
32423 Minden  
Phone: +49571 887-0 | Fax: +49571 887-169  
Email: [info.de@wago.com](mailto:info.de@wago.com) | Web: [www.wago.com](http://www.wago.com)

Do you have any questions about our products?  
We are always happy to take your call at +49 (571) 887-44222.



Subject to changes. Please also observe the further product documentation!

RoHS   
Compliant

BOMcheck.net

Color: 

## Data

### Technical Data

Main product function	Ferrule
Querschnitt Hülse AWG	14 AWG
Hülse für	2.5 mm <sup>2</sup>

### Connection data

Strip length	14 mm / 0.55 inch
--------------	-------------------

### Geometrical Data

Length	19 mm
Length 1	12 mm
Diameter	4.7 mm
Diameter 1	4.2 mm
Diameter 2	2.2 mm

### Material Data

Color	blue
Fire load	0.002 MJ
Weight	0.2 g

### Commercial data

Product Group	2 (Terminal Block Accessories)
Packaging type	BOX
Country of origin	DE
GTIN	4044918604314
Customs Tariff No.	85369010000

### Counterpart

Subject to changes. Please also observe the further product documentation!

WAGO Kontakttechnik GmbH & Co. KG  
 Hansastr. 27  
 32423 Minden  
 Phone: +49571 887-0 | Fax: +49571 887-169  
 Email: [info.de@wago.com](mailto:info.de@wago.com) | Web: [www.wago.com](http://www.wago.com)

Do you have any questions about our products?  
 We are always happy to take your call at +49 (571) 887-44222.

## Installation Notes

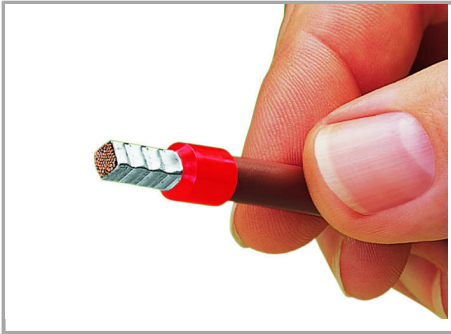

A perfect gas-tight crimp – both electrically and mechanically reliable

Subject to changes. Please also observe the further product documentation!