

Data sheet | Item number: 216-224

Ferrule; Sleeve for 1.5 mm² / AWG 16; insulated; electro-tin plated; black

www.wago.com/216-224

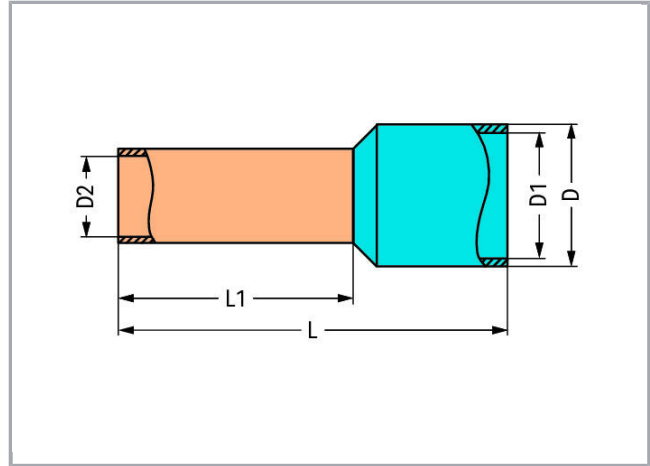

Subject to changes. Please also observe the further product documentation!

WAGO Kontakttechnik GmbH & Co. KG
Hansastr. 27
32423 Minden
Phone: +49571 887-0 | Fax: +49571 887-169
Email: info.de@wago.com | Web: www.wago.com

Do you have any questions about our products?
We are always happy to take your call at +49 (571) 887-44222.



Subject to changes. Please also observe the further product documentation!



Data

Technical Data

Main product function	Ferrule
Querschnitt Hülse AWG	16 AWG
Hülse für	1.5 mm ²

Connection data

Strip length	8 mm / 0.31 inch
--------------	------------------

Geometrical Data

Length	12 mm
Length 1	6 mm
Diameter	4 mm
Diameter 1	3.5 mm
Diameter 2	1.7 mm

Material Data

Color	black
Weight	0.1 g

Commercial data

Product Group	2 (Terminal Block Accessories)
Packaging type	BOX
Country of origin	DE
GTIN	4017332277488
Customs Tariff No.	85369010000

Counterpart

Subject to changes. Please also observe the further product documentation!

WAGO Kontakttechnik GmbH & Co. KG
Hansastr. 27
32423 Minden
Phone: +49571 887-0 | Fax: +49571 887-169
Email: info.de@wago.com | Web: www.wago.com

Do you have any questions about our products?
We are always happy to take your call at +49 (571) 887-44222.

Installation Notes

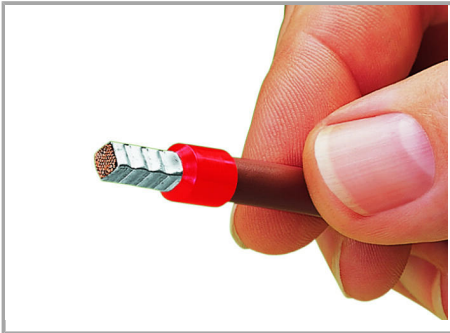

A perfect gas-tight crimp – both electrically and mechanically reliable

Subject to changes. Please also observe the further product documentation!