

Data sheet | Item number: 216-151

Ferrule; Sleeve for 0.25 mm² / AWG 24; uninsulated; electro-tin plated

www.wago.com/216-151

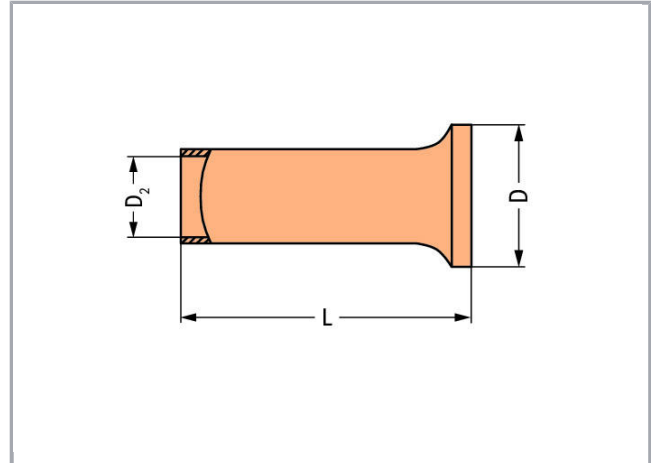

Data

Technical Data

Main product function	Ferrule
Querschnitt Hülse AWG	24 AWG

Subject to changes. Please also observe the further product documentation!

WAGO Kontakttechnik GmbH & Co. KG
Hansastr. 27
32423 Minden
Phone: +49571 887-0 | Fax: +49571 887-169
Email: info.de@wago.com | Web: www.wago.com

Do you have any questions about our products?
We are always happy to take your call at +49 (571) 887-44222.

Hülse für	0.25 mm ²
-----------	----------------------

Connection data

Strip length	5 mm / 0.2 inch
--------------	-----------------

Geometrical Data

Length	5 mm
Diameter	1.7 mm
Diameter 2	0.75 mm

Material Data

Weight	0 g
--------	-----

Commercial data

Product Group	2 (Terminal Block Accessories)
Packaging type	BOX
Country of origin	DE
GTIN	4017332277563
Customs Tariff No.	85369010000

Counterpart

Installation Notes

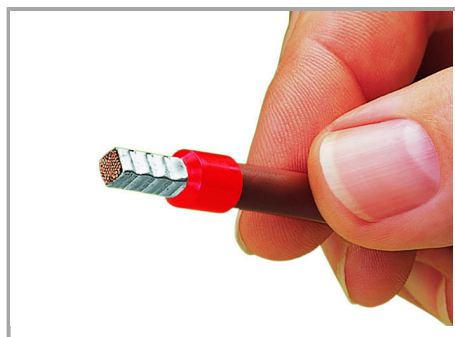

A perfect gas-tight crimp – both electrically and mechanically reliable

Subject to changes. Please also observe the further product documentation!