

RAD-ADP-RSMA/M-RSMA/F-90 - Adapter



2904790

<https://www.phoenixcontact.com/us/products/2904790>

Please be informed that the data shown in this PDF document is generated from our online catalog. Please find the complete data in the user documentation. Our general terms of use for downloads are valid.



Antenna adapter, frequency range: 0.3 GHz ... 6 GHz, connection: RSMA (male) -> RSMA (female), 90° angled

Your advantages

- As an adapter between devices and cables
- Adapter for installing the antenna inside buildings

Commercial data

Item number	2904790
Packing unit	1 pc
Sales key	DN23
Product key	DNC6A3
GTIN	4046356888264
Weight per piece (including packing)	5.3 g
Weight per piece (excluding packing)	5.195 g
Customs tariff number	85366910
Country of origin	US

RAD-ADP-RSMA/M-RSMA/F-90 - Adapter

2904790

<https://www.phoenixcontact.com/us/products/2904790>

Technical data

Product properties

Product type	Coaxial adapter
--------------	-----------------

Electrical properties

Frequency range	0.3 GHz ... 6 GHz
-----------------	-------------------

Connection data

Connection method	RSMA (male) -> RSMA (female)
-------------------	------------------------------

Dimensions

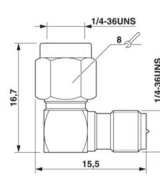
Dimensional drawing	
Width	15.5 mm
Height	16.7 mm

Material specifications

Housing material	Brass (CuZn)
------------------	--------------

Environmental and real-life conditions

Ambient conditions

Degree of protection	IP20
Ambient temperature (operation)	-65 °C ... 165 °C
Ambient temperature (storage/transport)	-65 °C ... 165 °C

Mounting

Mounting type	Connection-specific intermediate plugging
Assembly instructions	Indoor installation

RAD-ADP-RSMA/M-RSMA/F-90 - Adapter



2904790

<https://www.phoenixcontact.com/us/products/2904790>

Classifications

ECLASS

ECLASS-11.0	19070417
ECLASS-12.0	19070417
ECLASS-13.0	19070417

ETIM

ETIM 9.0	EC001135
----------	----------

UNSPSC

UNSPSC 21.0	39121400
-------------	----------

RAD-ADP-RSMA/M-RSMA/F-90 - Adapter



2904790

<https://www.phoenixcontact.com/us/products/2904790>

Environmental product compliance

China RoHS	Environmentally friendly use period: unlimited = EFUP-e
	No hazardous substances above threshold values

Phoenix Contact 2024 © - all rights reserved
<https://www.phoenixcontact.com>

Phoenix Contact USA
586 Fulling Mill Road
Middletown, PA 17057, United States
(+717) 944-1300
info@phoenixcon.com