

FL-PP-RJ45-LSA - Patch panel



2901645

<https://www.phoenixcontact.com/us/products/2901645>

Please be informed that the data shown in this PDF document is generated from our online catalog. Please find the complete data in the user documentation. Our general terms of use for downloads are valid.



Patch panel, one RJ45 jack to 8 LSA connection terminal blocks (1:1 assignment), CAT5e, 10/100/1000 Mbps, DIN rail adapter, IP20, option of shield contacting to the DIN rail via bridges

Product description

Ethernet patch panels enable quick and easy connection between the field cabling and control cabinet cabling. The passive termination panels are a convenient alternative to the on-site assembly of RJ45 connectors.

Your advantages

- Safe shield connection to ground potential
- CAT5e
- Mounting on a DIN rail
- 10/100/1000 Mbps
- Optional shield connection via jumpers
- Shipbuilding approval in accordance with DNV GL
- PoE-capable in accordance with IEEE 802.3bt, type 4

Commercial data

Item number	2901645
Packing unit	10 pc
Minimum order quantity	10 pc
Sales key	DN07
Product key	DNC331
Catalog page	Page 363 (C-6-2019)
GTIN	4046356622790
Weight per piece (including packing)	54.218 g
Weight per piece (excluding packing)	56 g
Customs tariff number	85366990
Country of origin	US

FL-PP-RJ45-LSA - Patch panel



2901645

<https://www.phoenixcontact.com/us/products/2901645>

Technical data

Product properties

Product type	Patch panel
MTBF	6702 Years (Telcordia standard, 25°C temperature, 21% operating cycle (5 days a week, 8 hours a day))
	2962 Years (Telcordia standard, 40°C temperature, 34.25% operating cycle (5 days a week, 12 hours a day))

Connection data

Connection method	LSA-PLUS
-------------------	----------

Interfaces

Data: Ethernet interface, 10/100/1000Base-T(X) in accordance with IEEE 802.3

Serial transmission speed	10/100/1000 Mbps
Connection method	LSA
No. of channels	1
Pin assignment	1:1
Transmission length	100 m (including patch cables)
Single conductor/terminal point, rigid	0.128 mm ² ... 0.325 mm ²
Single-wire/terminal point, flexible	0.128 mm ² ... 0.325 mm ²
Single-wire/terminal point, rigid AWG max.	22
Single-wire/terminal point, rigid AWG min.	26

Data: Ethernet interface, 10/100/1000Base-T(X) in accordance with IEEE 802.3

Connection method	RJ45 CAT5e
No. of channels	1

Dimensions

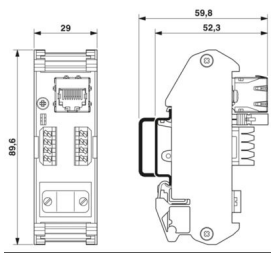
Dimensional drawing	
Width	29 mm
Height	90 mm
Depth	53 mm

Material specifications

Color (Housing)	green (RAL 6021)
Material Housing	PVC / PA

FL-PP-RJ45-LSA - Patch panel



2901645

<https://www.phoenixcontact.com/us/products/2901645>

Cable/line

External cable diameter ()	6 mm ... 10 mm
Cable impedance	100 Ω

Mechanical properties

Mechanical data

Insertion/withdrawal cycles	≤ 2500
-----------------------------	--------

Environmental and real-life conditions

Ambient conditions

Degree of protection	IP20
Ambient temperature (operation)	-25 °C ... 70 °C
Ambient temperature (storage/transport)	-25 °C ... 85 °C
Ambient temperature (assembly)	-10 °C ... 70 °C
Permissible humidity (operation)	25 % ... 95 % (non-condensing)

Approvals

EAC

Identification	EAC
----------------	-----

Corrosive gas test

Identification	ISA-S71.04-1985 G3 Harsh Group A
----------------	----------------------------------

Shipbuilding

Identification	DNV GL
----------------	--------

DNV GL data

Temperature	B
Humidity	A
Vibration	A
EMC	B
Enclosure	Required protection according to the Rules shall be provided upon installation on board

Mounting

Mounting type	DIN rail mounting
---------------	-------------------

FL-PP-RJ45-LSA - Patch panel



2901645

<https://www.phoenixcontact.com/us/products/2901645>

Classifications

ECLASS

ECLASS-11.0	19170112
ECLASS-12.0	19170112
ECLASS-13.0	19170112

ETIM

ETIM 9.0	EC002697
----------	----------

UNSPSC

UNSPSC 21.0	43223300
-------------	----------

FL-PP-RJ45-LSA - Patch panel



2901645

<https://www.phoenixcontact.com/us/products/2901645>

Environmental product compliance

REACH SVHC	Lead 7439-92-1
China RoHS	Environmentally Friendly Use Period = 50 years
	For information on hazardous substances, refer to the manufacturer's declaration available under "Downloads"

Phoenix Contact 2024 © - all rights reserved

<https://www.phoenixcontact.com>

Phoenix Contact USA
586 Fulling Mill Road
Middletown, PA 17057, United States
(+717) 944-1300
info@phoenixcon.com