

IB IL 24 DO 4-ME - Digital module



2863931

<https://www.phoenixcontact.com/us/products/2863931>

Please be informed that the data shown in this PDF document is generated from our online catalog. Please find the complete data in the user documentation. Our general terms of use for downloads are valid.

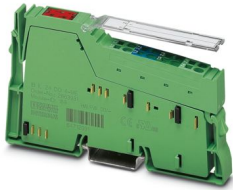

Inline, Digital output terminal, Digital outputs: 4, 24 V DC, connection technology: 3-conductor, transmission speed in the local bus: 500 kbps, degree of protection: IP20, including Inline connector and labeling field

Product description

The terminal is designed for use within an Inline station. It is used to output digital signals. It is used to acquire analog voltage and current signals.

Your advantages

- 4 digital outputs
- Connection of actuators in 2- and 3-conductor technology
- Nominal current per output: 500 mA
- Total current of the terminal: 2 A
- Short-circuit and overload-protected outputs
- Diagnostic and status indicators

Commercial data

Item number	2863931
Packing unit	4 pc
Minimum order quantity	4 pc
Sales key	DR01
Product key	DRI132
Catalog page	Page 128 (C-6-2019)
GTIN	4017918962661
Weight per piece (including packing)	68.375 g
Weight per piece (excluding packing)	59 g
Customs tariff number	85389099
Country of origin	DE

IB IL 24 DO 4-ME - Digital module

2863931

<https://www.phoenixcontact.com/us/products/2863931>

Technical data

Dimensions

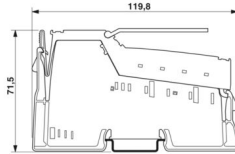
Dimensional drawing	
Width	12.2 mm
Height	119.8 mm
Depth	71.5 mm

Notes

Utilization restriction

CCCex note	Use in potentially explosive areas is not permitted in China.
------------	---

Interfaces

Inline local bus

Number of interfaces	2
Connection method	Inline data jumper
Transmission speed	500 kbps
Transmission physics	Copper

System properties

Module

ID code (dec.)	189
ID code (hex)	BD
Length code (hex)	41
Length code (dec)	65
Process data channel	4 bit
Input address area	0 bit
Output address area	4 bit
Register length	4 bit
Required parameter data	3 Byte
Required configuration data	4 Byte

Output data

Digital

Output name	Digital outputs
Connection method	Spring-cage connection

IB IL 24 DO 4-ME - Digital module



2863931

<https://www.phoenixcontact.com/us/products/2863931>

Connection technology	3-conductor
Number of outputs	4
Protective circuit	Overload protection, short-circuit protection of outputs; Zener diode in output chip
Output voltage	24 V DC ($U_S - 1 \text{ V}$)
Limitation of the voltage induced on circuit interruption	-46 V ... -15 V
Maximum inrush current	max. 1.5 A (for 20 ms)
Maximum output current per channel	500 mA
Maximum output current per module	2 A
Nominal output voltage	24 V DC (voltage difference at $I_{nom} \leq 1 \text{ V}$)
Output voltage when switched off	max. 2 V
Output current when switched off	max. 300 μA
Nominal load, inductive	12 VA (1.2 H, 50 Ω)
Nominal load, lamp	12 W
Nominal load, ohmic	12 W (48 Ω)
Maximum operating frequency with ohmic nominal load	max. 300 Hz (this switching frequency is limited by the number of bus devices, the structure of the bus, the software used and the control or computer system used)
Reverse voltage resistance to short pulses	Reverse voltage proof
Behavior with overload	Auto restart
Behavior with inductive overload	Output can be destroyed
Behavior at voltage switch-off	The output follows the power supply without delay
Overcurrent shut-down	min. 0.7 A
Output current with ground connection interrupt when switched off	max. 25 mA
Output name	Digital outputs
Connection method	Spring-cage connection
Connection technology	3-conductor
Number of outputs	4
Protective circuit	Overload protection, short-circuit protection of outputs; Zener diode in output chip
Output voltage	24 V DC ($U_S - 1 \text{ V}$)
Limitation of the voltage induced on circuit interruption	-46 V ... -15 V
Maximum inrush current	max. 1.5 A (for 20 ms)
Maximum output current per channel	500 mA
Maximum output current per module	2 A
Nominal output voltage	24 V DC (voltage difference at $I_{nom} \leq 1 \text{ V}$)
Output voltage when switched off	max. 2 V
Output current when switched off	max. 300 μA
Nominal load, inductive	12 VA (1.2 H, 50 Ω)
Nominal load, lamp	12 W
Nominal load, ohmic	12 W (48 Ω)
Maximum operating frequency with ohmic nominal load	max. 300 Hz (this switching frequency is limited by the number of bus devices, the structure of the bus, the software used and the control or computer system used)
Reverse voltage resistance to short pulses	Reverse voltage proof

IB IL 24 DO 4-ME - Digital module



2863931

<https://www.phoenixcontact.com/us/products/2863931>

Behavior with overload	Auto restart
Behavior with inductive overload	Output can be destroyed
Behavior at voltage switch-off	The output follows the power supply without delay
Overcurrent shut-down	min. 0.7 A
Output current with ground connection interrupt when switched off	max. 25 mA

Product properties

Type	modular
Product type	I/O component
Product family	Inline
Scope of delivery	including Inline connector and labeling field
No. of channels	4
Operating mode	Process data operation with 4 bits Process data operation with 4 bits
Diagnostics messages	Short-circuit or overload of the digital outputs Error message in the diagnostic code (bus) and display (2 Hz) via the LED (D) on the module

Electrical properties

Maximum power dissipation for nominal condition	48 W
---	------

Potentials: Communications power (U_L)

Supply voltage	7.5 V DC (via voltage jumper)
Current draw	max. 44 mA
Power consumption	max. 0.33 W

Potentials: Segment circuit supply (U_S)

Supply voltage	24 V DC (via voltage jumper)
Supply voltage range	19.2 V DC ... 30 V DC (including all tolerances, including ripple)
Current draw	max. 2 A

Electrical isolation/isolation of the voltage ranges

Test voltage: 7.5 V supply (bus logics)/24 V supply (I/O)	500 V AC, 50 Hz, 1 min.
Test voltage: 7.5 V supply (bus logic)/functional ground	500 V AC, 50 Hz, 1 min.
Test voltage: 24 V supply (I/O) / functional ground	500 V AC, 50 Hz, 1 min.

Connection data

Connection technology

Connection name	Inline connector
-----------------	------------------

Conductor connection

Connection method	Spring-cage connection
Conductor cross section rigid	0.08 mm ² ... 1.5 mm ²
Conductor cross section flexible	0.08 mm ² ... 1.5 mm ²
Conductor cross section AWG	28 ... 16
Stripping length	8 mm

2863931

<https://www.phoenixcontact.com/us/products/2863931>

Inline connector

Connection method	Spring-cage connection
Conductor cross section, rigid	0.08 mm ² ... 1.5 mm ²
Conductor cross section, flexible	0.08 mm ² ... 1.5 mm ²
Conductor cross section AWG	28 ... 16
Stripping length	8 mm

Environmental and real-life conditions

Ambient conditions

Ambient temperature (operation)	-25 °C ... 55 °C
Degree of protection	IP20
Air pressure (operation)	70 kPa ... 106 kPa (up to 3000 m above sea level)
Air pressure (storage/transport)	70 kPa ... 106 kPa (up to 3000 m above sea level)
Ambient temperature (storage/transport)	-25 °C ... 85 °C
Permissible humidity (operation)	10 % ... 95 % (according to DIN EN 61131-2)
Permissible humidity (storage/transport)	10 % ... 95 % (according to DIN EN 61131-2)

Standards and regulations

Protection class	III (IEC 61140, EN 61140, VDE 0140-1)
------------------	---------------------------------------

Mounting

Mounting type	DIN rail mounting
---------------	-------------------

2863931

<https://www.phoenixcontact.com/us/products/2863931>

Classifications

ECLASS

ECLASS-11.0	27242604
ECLASS-12.0	27242604
ECLASS-13.0	27242604

ETIM

ETIM 9.0	EC001599
----------	----------

UNSPSC

UNSPSC 21.0	32151600
-------------	----------

IB IL 24 DO 4-ME - Digital module



2863931

<https://www.phoenixcontact.com/us/products/2863931>

Environmental product compliance

REACH SVHC	Lead 7439-92-1
China RoHS	Environmentally Friendly Use Period = 50 years
	For information on hazardous substances, refer to the manufacturer's declaration available under "Downloads"

Phoenix Contact 2024 © - all rights reserved

<https://www.phoenixcontact.com>

Phoenix Contact USA
586 Fulling Mill Road
Middletown, PA 17057, United States
(+717) 944-1300
info@phoenixcon.com