

VAL-MS 1000DC-PV-ST - Type 2 surge protection plug



2800624

<https://www.phoenixcontact.com/us/products/2800624>

Please be informed that the data shown in this PDF document is generated from our online catalog. Please find the complete data in the user documentation. Our general terms of use for downloads are valid.

Replacement plug for PV arrester combinations from the VAL-MS 1000DC-PV-... product range



Your advantages

- Increased safety, thanks to compliance with standard EN 50539-11
- Reliable contact, thanks to integrated rotating latch
- Easy replacement, thanks to plug-in arresters
- Optimum inverter protection, thanks to low protection level
- Efficient replacement of defective plugs, thanks to visual status indicator
- Protection against mismatching, thanks to keyed plugs and base elements

Commercial data

Item number	2800624
Packing unit	1 pc
Minimum order quantity	1 pc
Sales key	CL01
Product key	CL1324
Catalog page	Page 73 (C-4-2019)
GTIN	4046356615099
Weight per piece (including packing)	74.6 g
Weight per piece (excluding packing)	73 g
Customs tariff number	85363090
Country of origin	CN

VAL-MS 1000DC-PV-ST - Type 2 surge protection plug



2800624

<https://www.phoenixcontact.com/us/products/2800624>

Technical data

Product properties

IEC test classification	PV II
	PV T2
EN type	T2
IEC power supply system	DC
Type	Male
Product type	Replacement plug
Product family	VALVETRAB MS
Installation location	Interior
Installation location of the disconnect device	Internal
Accessibility	Accessible
SPD failure behavior	OCFM (Open-Circuit Failure Mode)
Surge protection fault message	optical

Insulation characteristics

Overvoltage category	III
Pollution degree	2

Connection data

Connection method	pluggable
-------------------	-----------

Dimensions

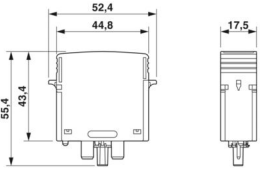
Dimensional drawing	
Width	17.5 mm
Height	52.4 mm
Depth	55.3 mm
Horizontal pitch	1 Div.

Material specifications

Color	black (RAL 9005)
	black (RAL 9005)
Flammability rating according to UL 94	V-0
CTI value of material	600
Insulating material	PA 6.6-FR
Material group	I
Housing material	PA 6.6-FR

2800624

<https://www.phoenixcontact.com/us/products/2800624>

Protective circuit

Standby power consumption P_C	≤ 25.00 mVA
Nominal discharge current I_n (8/20) μs	15 kA
Maximum discharge current I_{max} (8/20) μs	40 kA
Voltage protection level U_p	≤ 1.9 kV
Residual voltage U_{res}	≤ 1.9 kV (at I_n)
	≤ 1.5 kV (at 5 kA)
	≤ 1.7 kV (at 10 kA)
	≤ 2 kV (at 20 kA)
	≤ 2.3 kV (at 30 kA)
	≤ 2.5 kV (at 40 kA)
Response time t_A	≤ 25 ns

Protective circuit DC voltage side (DC)

Open circuit voltage U_{OCSTC}	≤ 487.5 V DC
Maximum discharge current I_{max} (8/20) μs	40 kA
Response time t_A	≤ 25 ns
Insulation resistance R_{iso}	> 5 G Ω (at 500 V DC)
Nominal discharge current I_n (8/20) μs	15 kA
Continuous operating current I_{CPV}	< 20 μA
Maximum continuous operating voltage U_{CPV}	585 V DC
Short-circuit current rating I_{SCPV}	2000 A
Residual voltage U_{res}	≤ 1.9 kV (at I_n)
	≤ 1.5 kV (at 5 kA)
	≤ 1.7 kV (at 10 kA)
	≤ 2 kV (at 20 kA)
	≤ 2.3 kV (at 30 kA)
	≤ 2.5 kV (at 40 kA)
Voltage protection level U_p	≤ 1.9 kV
Standby power consumption P_C	≤ 25.00 mVA

Environmental and real-life conditions

Ambient conditions

Degree of protection	IP20
Ambient temperature (operation)	-40 °C ... 80 °C
Ambient temperature (storage/transport)	-40 °C ... 80 °C
Altitude	≤ 2000 m (amsl)
Permissible humidity (operation)	5 % ... 95 %
Shock (operation)	60g (Half-sine / 11 ms / 3x $\pm X$, $\pm Y$, $\pm Z$)
Vibration (operation)	7.5g (5-500 Hz/2.5 h/XYZ)

Approvals

UL specifications

VAL-MS 1000DC-PV-ST - Type 2 surge protection plug



2800624

<https://www.phoenixcontact.com/us/products/2800624>

Maximum continuous operating voltage MCOV	1170 V DC
Short-circuit current rating (SCCR)	50 kA
Voltage protection rating VPR	3 kV
Nominal discharge current I_n	10 kA
Mode of protection	(L+) - (L-)
	(L+) - G
	(L-) - G
Nominal voltage	1170 V DC
Power distribution system	DC PV
SPD Type	1CA

Standards and regulations

Standards/specifications	EN 61643-31
Note	2019
Standards/specifications	IEC 61643-31
Note	2018

Mounting

Mounting type	on base element
---------------	-----------------

VAL-MS 1000DC-PV-ST - Type 2 surge protection plug



2800624

<https://www.phoenixcontact.com/us/products/2800624>

Classifications

ECLASS

ECLASS-11.0	27130890
ECLASS-13.0	27171492

ETIM

ETIM 9.0	EC002496
----------	----------

UNSPSC

UNSPSC 21.0	39121620
-------------	----------

VAL-MS 1000DC-PV-ST - Type 2 surge protection plug



2800624

<https://www.phoenixcontact.com/us/products/2800624>

Environmental product compliance

China RoHS	Environmentally friendly use period: unlimited = EFUP-e
	No hazardous substances above threshold values

Phoenix Contact 2024 © - all rights reserved
<https://www.phoenixcontact.com>

Phoenix Contact USA
586 Fulling Mill Road
Middletown, PA 17057, United States
(+717) 944-1300
info@phoenixcon.com