

PV-FT-CF-C-2,5-300-BU - Device connector front mounting



1705995

<https://www.phoenixcontact.com/us/products/1705995>

Please be informed that the data shown in this PDF document is generated from our online catalog. Please find the complete data in the user documentation. Our general terms of use for downloads are valid.



Device connector front mounting, Range of articles: SUNCLIX, housing material: PPE, color: black, number of positions: 1, min. conductor cross section: 2.5 mm², rated voltage: 1000 V DC, rated current: 27 A, Connection method: Crimp, Contact connection type: Socket, cable length: 300

Commercial data

Item number	1705995
Packing unit	50 pc
Minimum order quantity	50 pc
Sales key	AB02
Product key	ABLBA
GTIN	4046356828321
Weight per piece (including packing)	15.544 g
Weight per piece (excluding packing)	15.544 g
Customs tariff number	85444290
Country of origin	DE

PV-FT-CF-C-2,5-300-BU - Device connector front mounting



1705995

<https://www.phoenixcontact.com/us/products/1705995>

Technical data

Notes

Safety note

Safety note

- **WARNING:** Commission properly functioning products only. The products must be regularly inspected for damage. Decommission defective products immediately. Replace damaged products. Repairs are not possible.
- **WARNING:** Only electrically qualified personnel may install and operate the product. They must observe the following safety notes. The qualified personnel must be familiar with the basics of electrical engineering. They must be able to recognize and prevent danger. The relevant symbol on the packaging indicates that only personnel familiar with electrical engineering are allowed to install and operate the product.
- **WARNING:** The connectors may not be plugged in or disconnected under load. Ignoring the warning or improper use may damage persons and/or property.
- The products are suitable for applications in plant, controller, and electrical device engineering.
- Assembled products may not be manipulated or improperly opened.
- Only use mating connectors that are specified in the technical data of the standards listed (e.g. the ones listed in the product accessories online at [phoenixcontact.com/products](https://www.phoenixcontact.com/products)).
- When using the product in direct connection with third-party manufacturers, the user is responsible.
- For operating voltages > 50 V AC, conductive connector housings must be grounded
- Ensure that the protective or functional ground has been properly connected.
- Observe the corresponding technical data. You will find information:
 - o On the product
 - o On the packing label
 - o In the supplied documentation
 - o Online at [phoenixcontact.com/products](https://www.phoenixcontact.com/products) under the product
- The installation notes/Design In documents online on the download page at [phoenixcontact.com/products](https://www.phoenixcontact.com/products) must be observed for this product.
- Use a protective cap to protect connectors that are not in use. The suitable accessories are available online in the accessory section of the product at [phoenixcontact.com/products](https://www.phoenixcontact.com/products)
- The connector warms up in normal operation. Depending on the ambient conditions, the surface of the connector can continue to warm up. In this case, the user is responsible for posting warnings (e.g. DIN EN ISO 13732-1:2008-12).
- Operate the connector only when it is fully plugged in and interlocked.
- Ensure that when laying the cable, the tensile load on the connectors does not exceed the upper limit specified in the standards.

PV-FT-CF-C-2,5-300-BU - Device connector front mounting



1705995

<https://www.phoenixcontact.com/us/products/1705995>

- Observe the minimum bending radius of the cable. Lay the cable without twisting it.

Product properties

Product type	Panel feed-through
Product family	SUNCLIX
Number of positions	1

Insulation characteristics

Protection class	II
Degree of pollution	2

Connection data

Conductor connection

Tightening torque	1.8 Nm \pm 0.1 Nm
-------------------	---------------------

Dimensions

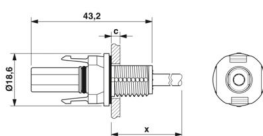
Dimensional drawing	
Width	18.6 mm
Height	18.6 mm
Length	43.2 mm

Electrical properties

Rated voltage (III/2)	1000 V
Nominal voltage ATD	1000 V DC in accordance with IEC 62852:2014/AMD1:2020
Rated surge voltage (III/2)	12 kV
Rated current (2.5 mm ²)	27 A (in accordance with IEC 62852:2014/AMD1:2020)
Contact resistance	0.45 m Ω
Contact resistance	\leq 0.45 m Ω (when plugged in (without cable))

Mechanical properties

Mechanical data

Insertion/withdrawal cycles	100
Insertion force	45 N \pm 10 N
Withdrawal force	250 N \pm 50 N (when locked)

Material specifications

Color	black
Color of the housing part	black
Material	PPE

PV-FT-CF-C-2,5-300-BU - Device connector front mounting



1705995

<https://www.phoenixcontact.com/us/products/1705995>

Flammability rating according to UL 94	V0
Insulating material group	III
Seal material	EPDM
Insulating material	mPPE
Contact surface	Silver Ag
Cable seal material	Elastosil LR 3065/50
Contact material	Cu
Contact surface material	Ag
Contact carrier material	PPE
O-ring material	Silopren
Housing material	PPE
Outer sheath, material	PE-X

Cable/line

Cable length	300 mm
Cable type	S01
Structure of individual litz in acc. with VDE 0295 / smallest wire diameter	50x0.25
Cable type	Hose line
Cable structure	50 x 0.25 mm Ø litz wires, tin-plated, 1x bunched
External cable diameter	4.25 mm ±0.15 mm
Outer sheath, material	PE-X
External sheath, color	blue RAL 5015
Single wire, material	Cu
Single wire, cross section	2.5 mm ²
Cable cross section	2.5 mm ²
Nominal voltage, cable	1.8 kV DC (max U (conductor / conductor, ungrounded system))
Test voltage, cable	≥ 8 kV AC (Spark test online (standard designation))
Smallest bending radius, fixed installation	21.25 mm (5x Ø)
Smallest bending radius, movable installation	40.25 mm (10x Ø)
Cable pull-out force	> 80 N
Halogen-free	yes
Resistance to oil	no
Flame resistance	no

Environmental and real-life conditions

Ambient conditions

Degree of protection (when plugged in)	IP66 / IP68 (2 m / 24 h)
Degree of protection (not plugged in)	IP20
Ambient temperature (operation)	-40 °C ... 85 °C
Ambient temperature (assembly)	-25 °C ... 50 °C
Resistance to oil	no

Standards and regulations

PV-FT-CF-C-2,5-300-BU - Device connector front mounting



1705995

<https://www.phoenixcontact.com/us/products/1705995>

Flame resistance	no
Resistance to oil	no
Standards/specifications	IEC 62852:2014/AMD1:2020

PV-FT-CF-C-2,5-300-BU - Device connector front mounting



1705995

<https://www.phoenixcontact.com/us/products/1705995>

Classifications

ECLASS

ECLASS-11.0	27440107
ECLASS-12.0	27440107
ECLASS-13.0	27440107

ETIM

ETIM 9.0	EC002635
----------	----------

UNSPSC

UNSPSC 21.0	39121400
-------------	----------

PV-FT-CF-C-2,5-300-BU - Device connector front mounting



1705995

<https://www.phoenixcontact.com/us/products/1705995>

Environmental product compliance

China RoHS	Environmentally friendly use period: unlimited = EFUP-e
	No hazardous substances above threshold values

Phoenix Contact 2024 © - all rights reserved
<https://www.phoenixcontact.com>

Phoenix Contact USA
586 Fulling Mill Road
Middletown, PA 17057, United States
(+717) 944-1300
info@phoenixcon.com