

# VS-25-BU-DSUB-5P-LH - D-SUB contact support



1655438

<https://www.phoenixcontact.com/us/products/1655438>

Please be informed that the data shown in this PDF document is generated from our online catalog. Please find the complete data in the user documentation. Our general terms of use for downloads are valid.

D-SUB contact carrier, shell size 3, accommodation for 5 combined contacts, type of contact socket, fixing with 4-40 UNC thread and solder pins, for panel mounting frame VS-25-...



## Your advantages

- Compatible with IP67 sleeve housing and panel-mount frame
- Easy assembly

## Commercial data

Item number	1655438
Packing unit	10 pc
Minimum order quantity	10 pc
Sales key	AB19
Product key	ABNCAB
Catalog page	Page 214 (C-2-2013)
GTIN	4046356029360
Weight per piece (including packing)	17.95 g
Weight per piece (excluding packing)	14.12 g
Customs tariff number	85366990
Country of origin	DE

# VS-25-BU-DSUB-5P-LH - D-SUB contact support



1655438

<https://www.phoenixcontact.com/us/products/1655438>

## Technical data

### Notes

General	The contacts must be ordered separately since they are not included in the scope of supply of the combi contact inserts.
---------	--

### Product properties

Type	D-SUB
Product type	Female insert
Number of positions	5
Connection profile	D-SUB
Application	Combination contact insert
Number of slots	1
Type	Socket
Shielded	yes

### Electrical properties

Transmission medium	Copper
---------------------	--------

### Connection data

#### Connection technology

Connection method	Wave soldering contacts
-------------------	-------------------------

### Dimensions

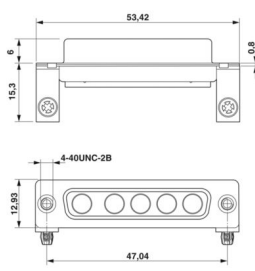
Dimensional drawing	
Width	21.6 mm
Height	53.4 mm
Length	17.07 mm

### Material specifications

Flammability rating according to UL 94	V0
Housing surface material	metal-plated
Contact surface material	Gold
Contact carrier material	PBTP
Housing material	Metal

### Mechanical properties

# VS-25-BU-DSUB-5P-LH - D-SUB contact support



1655438

<https://www.phoenixcontact.com/us/products/1655438>

## Mechanical data

Insertion/withdrawal cycles	≥ 500
-----------------------------	-------

## Environmental and real-life conditions

### Ambient conditions

Degree of protection	IP20
Ambient temperature (operation)	-55 °C ... 125 °C

## Mounting

Mounting type	Screw mounting
---------------	----------------

# VS-25-BU-DSUB-5P-LH - D-SUB contact support



1655438

<https://www.phoenixcontact.com/us/products/1655438>

## Classifications

### ECLASS

ECLASS-11.0	27440223
ECLASS-12.0	27440223
ECLASS-13.0	27440223

### ETIM

ETIM 9.0	EC003557
----------	----------

### UNSPSC

UNSPSC 21.0	39121400
-------------	----------

# VS-25-BU-DSUB-5P-LH - D-SUB contact support



1655438

<https://www.phoenixcontact.com/us/products/1655438>

## Environmental product compliance

REACH SVHC	Lead 7439-92-1
China RoHS	Environmentally Friendly Use Period = 50 years
	For information on hazardous substances, refer to the manufacturer's declaration available under "Downloads"

Phoenix Contact 2024 © - all rights reserved

<https://www.phoenixcontact.com>

Phoenix Contact USA  
586 Fulling Mill Road  
Middletown, PA 17057, United States  
(+717) 944-1300  
[info@phoenixcon.com](mailto:info@phoenixcon.com)