

Connector - QPD P 3PE2,5 6-10 BK - 1582202

Please be informed that the data shown in this PDF Document is generated from our Online Catalog. Please find the complete data in the user's documentation. Our General Terms of Use for Downloads are valid (<http://phoenixcontact.com/download>)



Connector, QUICKON connection, number of positions: 3+PE, 1 mm² ... 2.5 mm², 690 V, 20 A, black, cable diameter range: 6 mm ... 10 mm

Your advantages

- ✓ Innovative and time saving - QUICKON fast connection for time saving of up to 80 % for on-site connection
- ✓ Convenient: quick and easy assembly without special tools
- ✓ Robust throughout: housing with IP68/IP69K and IK07 protection for a wide range of applications
- ✓ Safer connection with mechanical coding to protect against mismatching, and touch-proof protection in accordance with DIN EN 0105
- ✓ Easy maintenance - the connectors enable fast device replacement and simplify startup thanks to pre-assembled cables



Key Commercial Data

Packing unit	1 pc
GTIN	 4 046356 316927
GTIN	4046356316927
Weight per Piece (excluding packing)	38.000 g
Custom tariff number	85366990
Country of origin	Germany

Technical data

General

Type	QPD 4x2,5
Color	black
Locking type	Screw locking
Connection method	QUICKON connection
	IDC connection

Connector - QPD P 3PE2,5 6-10 BK - 1582202

Technical data

General

Number of positions	4
Note number of positions	3+PE
Wrench size, union nut	22 mm
Tightening torque, union nut	5 Nm
Number of connections	4
Conductor cross section flexible min.	1 mm ²
Conductor cross section flexible max.	2.5 mm ²
Conductor cross section solid min.	1 mm ²
Conductor cross section solid max.	2.5 mm ²
Conductor cross section AWG min.	16
Conductor cross section AWG max.	14

Cabel

Structure of individual litz in acc. with VDE 0295 / smallest wire diameter	VDE 0295 class 1 to 6/min. 0.15 mm
Wire insulation material	PVC/PE/TPE/rubber
Wire diameter including insulation	2 mm ... 3.8 mm
External cable diameter	6 mm ... 10 mm
Position marking	1, 2, 3, PE

Ambient conditions

Degree of protection	IP66
	IP68 (2 m / 24 h)
	IP69K
Ambient temperature (operation)	-40 °C ... 100 °C
Ambient temperature (storage/transport)	-40 °C ... 80 °C
Temperature when conductor connected	-5 °C ... 50 °C

Electrical characteristics

Nominal current I _N	20 A
Rated current	20 A
rated voltage (III/3)	690 V
rated voltage (III/2)	1000 V
rated voltage (II/2)	1000 V
Rated surge voltage (III/3)	6 kV
Rated surge voltage (III/2)	8 kV
Rated surge voltage (II/2)	8 kV

Mechanical characteristics

QUICKON connectability	max. 10
------------------------	---------

Connector - QPD P 3PE2,5 6-10 BK - 1582202

Technical data

Mechanical characteristics

Insertion/withdrawal cycles	max. 50
Category of shock impact	IK07

Material data

Contact material	Cu
Contact surface material	silver-plated
Contact carrier material	PA
Insulating material	PA
Flammability rating according to UL 94	V0
Overvoltage category	III
Degree of pollution	3

Standards and Regulations

Category of shock impact	IK07
Flammability rating according to UL 94	V0

Environmental Product Compliance

China RoHS	Environmentally friendly use period: unlimited = EFUP-e
	No hazardous substances above threshold values

Drawings

Diagram

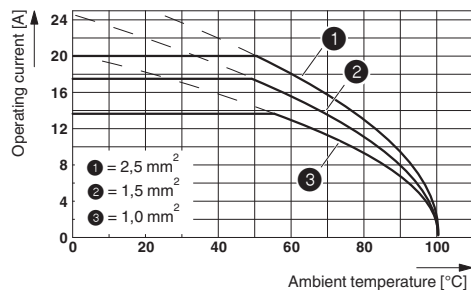

Dimensional drawing

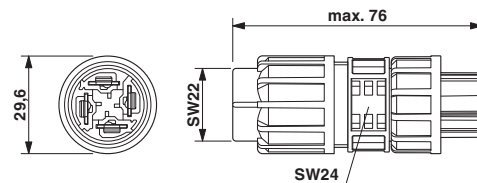

Dimensional drawing: connector, 2.5 mm²

Connector - QPD P 3PE2,5 6-10 BK - 1582202

Schematic diagram

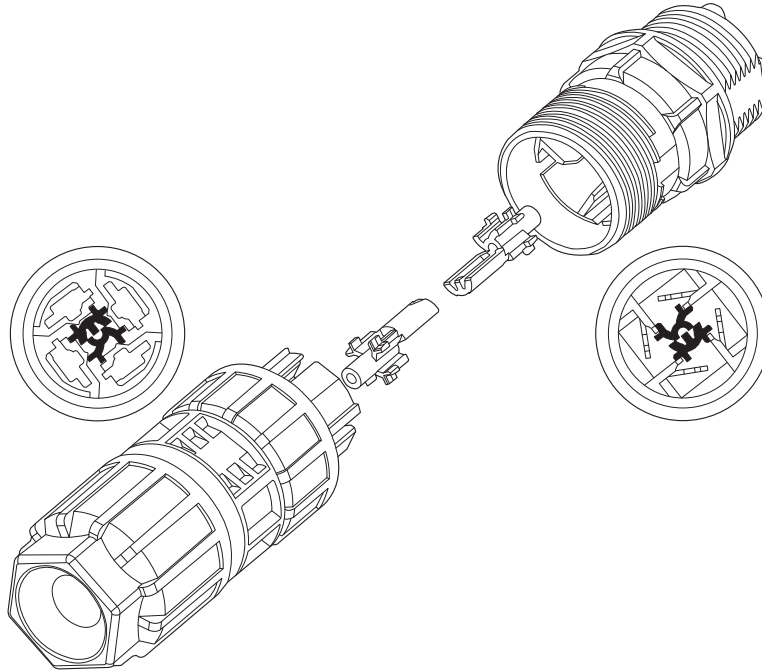

Coding of the QUICKON plug-in connection

Classifications

eCl@ss

eCl@ss 10.0.1	27440602
eCl@ss 11.0	27440602
eCl@ss 4.0	27140800
eCl@ss 4.1	27140800
eCl@ss 5.0	27143400
eCl@ss 5.1	27143400
eCl@ss 6.0	27143400
eCl@ss 7.0	27440605
eCl@ss 9.0	27440602

ETIM

ETIM 2.0	EC001297
ETIM 3.0	EC000516
ETIM 4.0	EC000516
ETIM 6.0	EC002566
ETIM 7.0	EC002566

Connector - QPD P 3PE2,5 6-10 BK - 1582202

Classifications

UNSPSC

UNSPSC 6.01	30211923
UNSPSC 7.0901	39121522
UNSPSC 11	39121522
UNSPSC 12.01	39121522
UNSPSC 13.2	39121522
UNSPSC 18.0	39121522
UNSPSC 19.0	39121522
UNSPSC 20.0	39121522
UNSPSC 21.0	39121522

Approvals

Approvals

Approvals

EAC / EAC / DNV GL / IECCE CB Scheme / UL Listed / cUL Listed / UL Listed / cUL Listed / VDE Zeichengenehmigung

Ex Approvals

Approval details

EAC		RU C- DE.AI30.B.01102
-----	--	--------------------------

EAC		RU C- DE.BL08.B.00511
-----	--	--------------------------

DNV GL		https://approvalfinder.dnvgl.com/	TAE00003J5
--------	--	---	------------

IECEE CB Scheme		http://www.iecee.org/	DE1-58228
-----------------	--	---	-----------

Connector - QPD P 3PE2,5 6-10 BK - 1582202

Approvals

UL Listed		http://database.ul.com/cgi-bin/XYV/template/LISEXT/1FRAME/index.htm	FILE E 221474
-----------	---	---	---------------

cUL Listed		http://database.ul.com/cgi-bin/XYV/template/LISEXT/1FRAME/index.htm	FILE E 221474
------------	---	---	---------------

UL Listed		http://database.ul.com/cgi-bin/XYV/template/LISEXT/1FRAME/index.htm	FILE E 468743
Nominal voltage UN	600 V		
Nominal current IN	10 A		
mm ² /AWG/kcmil	16		

cUL Listed		http://database.ul.com/cgi-bin/XYV/template/LISEXT/1FRAME/index.htm	FILE E 468743
Nominal voltage UN	600 V		
Nominal current IN	10 A		
mm ² /AWG/kcmil	16		

VDE Zeichengenehmigung		http://www2.vde.com/de/Institut/Online-Service/VDE-gepruefteProdukte/Seiten/Online-Suche.aspx	40029149
Nominal voltage UN	690 V		
Nominal current IN	20 A		
mm ² /AWG/kcmil	1.5-2.5		