

# VS-MP-PPC/CG-PO - Coupling



1403681

<https://www.phoenixcontact.com/us/products/1403681>

Please be informed that the data shown in this PDF document is generated from our online catalog. Please find the complete data in the user documentation. Our general terms of use for downloads are valid.



Coupling, design: Version 14, degree of protection: IP65, material: Metal, connection method: Spring-cage connection, color: black

## Product description

Push/pull data coupling; version 14

## Commercial data

Item number	1403681
Packing unit	1 pc
Minimum order quantity	1 pc
Sales key	AB17
Product key	ABNOGA
Catalog page	Page 361 (C-2-2019)
GTIN	4046356664301
Weight per piece (including packing)	288.3 g
Weight per piece (excluding packing)	288.3 g
Customs tariff number	85366990
Country of origin	DE

# VS-MP-PPC/CG-PO - Coupling

1403681

<https://www.phoenixcontact.com/us/products/1403681>

## Technical data

### Product properties

Type	Version 14
Product type	Network distributor box
Connection profile	Power
Number of slots	1

### Electrical properties

Nominal voltage $U_N$	24 V
Nominal current $I_N$	16 A
Transmission medium	Copper

### Connection data

#### Connection technology

Connection method	Spring-cage connection
-------------------	------------------------

### Dimensions

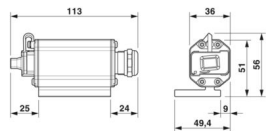
Dimensional drawing	
Width	42 mm
Height	51 mm
Length	115 mm

### Material specifications

Color	black
Housing material	Metal

### Cable/line

External cable diameter	9 mm ... 13 mm (Data cable gland)
-------------------------	-----------------------------------

### Mechanical properties

#### Mechanical data

Insertion/withdrawal cycles	≤ 100 (Power)
-----------------------------	---------------

### Environmental and real-life conditions

#### Ambient conditions

Degree of protection	IP65
Ambient temperature (operation)	-40 °C ... 70 °C

# VS-MP-PPC/CG-PO - Coupling

1403681

<https://www.phoenixcontact.com/us/products/1403681>



## Mounting

Mounting type

Screw mounting

# VS-MP-PPC/CG-PO - Coupling



1403681

<https://www.phoenixcontact.com/us/products/1403681>

## Classifications

### ECLASS

ECLASS-11.0	19179090
ECLASS-12.0	19179090
ECLASS-13.0	27061801

### ETIM

ETIM 9.0	EC002608
----------	----------

### UNSPSC

UNSPSC 21.0	43222600
-------------	----------

# VS-MP-PPC/CG-PO - Coupling



1403681

<https://www.phoenixcontact.com/us/products/1403681>

## Environmental product compliance

China RoHS	Environmentally friendly use period: unlimited = EFUP-e
	No hazardous substances above threshold values

Phoenix Contact 2024 © - all rights reserved  
<https://www.phoenixcontact.com>

Phoenix Contact USA  
586 Fulling Mill Road  
Middletown, PA 17057, United States  
(+717) 944-1300  
[info@phoenixcon.com](mailto:info@phoenixcon.com)