

SF-PZSL 2-100 S-VDE - Screwdriver



1212700

<https://www.phoenixcontact.com/us/products/1212700>

Please be informed that the data shown in this PDF document is generated from our online catalog. Please find the complete data in the user documentation. Our general terms of use for downloads are valid.



Screwdriver, positive/negative PZ/bladed, VDE insulated, size: PZ 2 x 100, 2-component grip, with non-slip grip

Your advantages

- VDE approval

Commercial data

Item number	1212700
Packing unit	10 pc
Minimum order quantity	10 pc
Sales key	BH31
Product key	BH3146
Catalog page	Page 447 (C-3-2019)
GTIN	4046356716635
Weight per piece (including packing)	91.04 g
Weight per piece (excluding packing)	91.04 g
Customs tariff number	82054000
Country of origin	CZ

SF-PZSL 2-100 S-VDE - Screwdriver



1212700

<https://www.phoenixcontact.com/us/products/1212700>

Technical data

Notes

Environmental Product Compliance

California Proposition 65

Further information on California's prop. 65 is available under "Downloads" in the manufacturer's declaration

Product properties

Type	Phillips
Product type	Screwdriver tools
Type	straight

Connection data

Output	Pozidrive/plus/minus
--------	----------------------

Dimensions

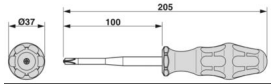
Dimensional drawing	
Width	37 mm
Blade width	6 mm
Blade height	100 mm
Length	205 mm
Wrench size for mounting	0 mm

Material specifications

Material	alloyed tool steel
----------	--------------------

Mounting

Wrench size	0 mm
-------------	------

SF-PZSL 2-100 S-VDE - Screwdriver



1212700

<https://www.phoenixcontact.com/us/products/1212700>

Classifications

ECLASS

ECLASS-11.0	21040406
ECLASS-12.0	21040406
ECLASS-13.0	21040406

ETIM

ETIM 9.0	EC000144
----------	----------

UNSPSC

UNSPSC 21.0	27111700
-------------	----------

Phoenix Contact 2024 © - all rights reserved

<https://www.phoenixcontact.com>

Phoenix Contact USA
586 Fulling Mill Road
Middletown, PA 17057, United States
(+717) 944-1300
info@phoenixcon.com