

# NS 35/ 7,5 AL PERF 2000MM - DIN rail perforated



0814681

<https://www.phoenixcontact.com/us/products/0814681>

Please be informed that the data shown in this PDF document is generated from our online catalog. Please find the complete data in the user documentation. Our general terms of use for downloads are valid.



DIN rail perforated, Pack of 25 (50 m), acc. to EN 60715, material: Aluminum, uncoated, Standard profile, color: aluminum color

## Commercial data

Item number	0814681
Packing unit	25 m
Minimum order quantity	25 m
Sales key	BE72
Product key	BE7245
Catalog page	Page 528 (C-3-2019)
GTIN	4017918982508
Weight per piece (including packing)	213 g
Weight per piece (excluding packing)	213 g
Customs tariff number	76042990
Country of origin	DE

# NS 35/ 7,5 AL PERF 2000MM - DIN rail perforated



0814681

<https://www.phoenixcontact.com/us/products/0814681>

## Technical data

### Product properties

Product type	DIN rail
--------------	----------

### Dimensions

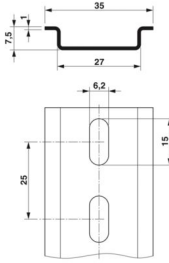
Dimensional drawing	
Width	35 mm
Hole width	15 mm
Height	2000 mm
Hole height	6.2 mm
Depth	7.5 mm
Length	2000 mm
Drill hole spacing	25 mm

### Material specifications

Color	aluminum color
Material	Aluminum
Coating	uncoated

### Standards and regulations

Tests	acc. to EN 60715
-------	------------------

# NS 35/ 7,5 AL PERF 2000MM - DIN rail perforated



0814681

<https://www.phoenixcontact.com/us/products/0814681>

## Classifications

### ECLASS

ECLASS-11.0	27400602
ECLASS-13.0	27400602
ECLASS-12.0	27400602

### ETIM

ETIM 9.0	EC001285
----------	----------

### UNSPSC

UNSPSC 21.0	39121700
-------------	----------

# NS 35/ 7,5 AL PERF 2000MM - DIN rail perforated



0814681

<https://www.phoenixcontact.com/us/products/0814681>

## Environmental product compliance

China RoHS	Environmentally friendly use period: unlimited = EFUP-e
	No hazardous substances above threshold values

Phoenix Contact 2024 © - all rights reserved  
<https://www.phoenixcontact.com>

Phoenix Contact USA  
586 Fulling Mill Road  
Middletown, PA 17057, United States  
(+717) 944-1300  
[info@phoenixcon.com](mailto:info@phoenixcon.com)