

CES-SRG-BK - Blind sleeve



0801670

<https://www.phoenixcontact.com/us/products/0801670>

Please be informed that the data shown in this PDF document is generated from our online catalog. Please find the complete data in the user documentation. Our general terms of use for downloads are valid.



Blind sleeve, small, no. of conductors: 0, type: Blind sleeve, closed, material: NBR, color: black, length: 29.5 mm, width: 19.5 mm, height: 17 mm

Product description

Blind sleeves seal feed-through sections that are not required in CES sealing frames

Commercial data

Item number	0801670
Packing unit	10 pc
Minimum order quantity	10 pc
Sales key	BF67
Product key	BF7CCX
Catalog page	Page 678 (C-2-2019)
GTIN	4046356674768
Weight per piece (including packing)	9.62 g
Weight per piece (excluding packing)	9.32 g
Customs tariff number	40169997
Country of origin	TW

CES-SRG-BK - Blind sleeve

0801670

<https://www.phoenixcontact.com/us/products/0801670>

Technical data

Product properties

Product type	Cable sleeve
No. of conductors	0

Dimensions

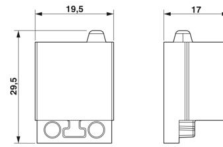
Dimensional drawing	
Width	19.5 mm
Height	17 mm
Length	29.5 mm

Material specifications

Material	NBR
----------	-----

Characteristics

Conductor sealing range	Blind sleeve
Seal size	small
Design, Format	Blind sleeve
Design, Cable seal	closed

Environmental and real-life conditions

Ambient conditions

Degree of protection	IP54
	IP65
Ambient temperature (operation)	-40 °C ... 125 °C (static)

Mounting

Assembly instructions	IP54: for vertical sealing frame mounting/for horizontal sealing frame mounting (downward cable outlet direction).
-----------------------	--

CES-SRG-BK - Blind sleeve



0801670

<https://www.phoenixcontact.com/us/products/0801670>

Classifications

ECLASS

ECLASS-11.0	27144425
ECLASS-12.0	27144425
ECLASS-13.0	27144425

ETIM

ETIM 9.0	EC000451
----------	----------

UNSPSC

UNSPSC 21.0	39121400
-------------	----------

CES-SRG-BK - Blind sleeve



0801670

<https://www.phoenixcontact.com/us/products/0801670>

Environmental product compliance

China RoHS	Environmentally friendly use period: unlimited = EFUP-e No hazardous substances above threshold values
------------	---

Phoenix Contact 2024 © - all rights reserved
<https://www.phoenixcontact.com>

Phoenix Contact USA
586 Fulling Mill Road
Middletown, PA 17057, United States
(+717) 944-1300
info@phoenixcon.com