

HDFK 25-VP - Panel feed-through terminal block



0709136

<https://www.phoenixcontact.com/us/products/0709136>

Please be informed that the data shown in this PDF document is generated from our online catalog. Please find the complete data in the user documentation. Our general terms of use for downloads are valid.



Panel feed-through terminal block, connection method: Screw connection with tension sleeve, Cable lug connection, number of positions: 1, load current: 101 A, cross section: 6 mm² - 35 mm², connection direction of the conductor to plug-in direction: 0 °, width: 15 mm

Your advantages

- Well-known connection principle allows worldwide use
- Low temperature rise, thanks to maximum contact force
- Tool-free snap-in principle enables easy mounting on the device panel
- Automatic panel thickness compensation enables universal use
- Reliable seal even with low-viscosity molding compounds

Commercial data

| | |
|--------------------------------------|--------------------|
| Item number | 0709136 |
| Packing unit | 50 pc |
| Minimum order quantity | 50 pc |
| Sales key | AA28 |
| Product key | AA1EAB |
| Catalog page | Page 635 (CC-2009) |
| GTIN | 4017918117009 |
| Weight per piece (including packing) | 48.48 g |
| Weight per piece (excluding packing) | 48.48 g |
| Customs tariff number | 85369010 |
| Country of origin | GR |

HDFK 25-VP - Panel feed-through terminal block



0709136

<https://www.phoenixcontact.com/us/products/0709136>

Technical data

Product properties

| | |
|-----------------------|-----------------------------------|
| Product type | Panel feed-through terminal block |
| Product family | HDFK 25-VP |
| Number of positions | 1 |
| Pitch | 15.1 mm |
| Number of connections | 2 |
| Number of rows | 1 |
| Number of potentials | 1 |

Insulation characteristics

| | |
|----------------------|-----|
| Overvoltage category | III |
| Degree of pollution | 3 |

Electrical properties

| | |
|-----------------------------|-------|
| Nominal current I_N | 101 A |
| Nominal voltage U_N | 500 V |
| Degree of pollution | 3 |
| Rated voltage (III/3) | 500 V |
| Rated surge voltage (III/3) | 6 kV |

Connection data

Connection technology

| | |
|-----------------------|--------------------|
| Connector system | HDFK 25 |
| Nominal cross section | 25 mm ² |

Conductor connection exterior

| | |
|---|--|
| Connection method | Screw connection with tension sleeve |
| Connection direction of the conductor to plug-in direction | 0 ° |
| Conductor cross section rigid | 6 mm ² ... 35 mm ² |
| Conductor cross section flexible | 10 mm ² ... 25 mm ² |
| Conductor cross section flexible, with ferrule without plastic sleeve | 4 mm ² ... 25 mm ² |
| Conductor cross section, flexible, with ferrule, with plastic sleeve | 4 mm ² ... 25 mm ² |
| 2 conductors with same cross section, solid | 2.5 mm ² ... 10 mm ² |
| 2 conductors with same cross section, flexible | 4 mm ² ... 10 mm ² |
| 2 conductors with same cross section, flexible, with ferrule without plastic sleeve | 2.5 mm ² ... 10 mm ² |
| 2 conductors with the same cross section, flexible, with TWIN ferrule with plastic sleeve | 2.5 mm ² ... 10 mm ² |
| Internal cylindrical gage | B8 |
| Stripping length | 19 mm |
| Tightening torque | 4 Nm ... 4.5 Nm |

HDFK 25-VP - Panel feed-through terminal block



0709136

<https://www.phoenixcontact.com/us/products/0709136>

Conductor connection interior

| | |
|--|----------------------|
| Connection method | Cable lug connection |
| Connection direction of the conductor to plug-in direction | 0 ° |

Material specifications

Material data - contact

| | |
|-------------------------|--|
| Note | WEEE/RoHS-compliant, free of whiskers according to IEC 60068-2-82/JEDEC JESD 201 |
| Contact material | Cu alloy |
| Surface characteristics | tin-plated |

Material data - housing

| | |
|---|-------------|
| Color (Housing) | gray (7042) |
| Insulating material | PA |
| Insulating material group | I |
| CTI according to IEC 60112 | 600 |
| Flammability rating according to UL 94 | V0 |
| Glow wire flammability index GWFI according to EN 60695-2-12 | 850 |
| Glow wire ignition temperature GWIT according to EN 60695-2-13 | 775 |
| Temperature for the ball pressure test according to EN 60695-10-2 | 125 °C |

Notes

Safety note

| | |
|-------------|--|
| Safety note | <ul style="list-style-type: none">• Only electrically qualified personnel may install and operate the product. To recognize and prevent danger, the qualified personnel must be familiar with the basics of electrical engineering.• Observe the technical data provided here and refer to the documents listed under "Downloads". The download area contains important information, such as installation notes, technical drawings, and 3D data.• The cable entry funnel is not safe to touch. Never connect or disconnect the terminal when it is energized. Take appropriate steps to ensure touch protection.• To maintain the nominal voltage, align the cable lugs straight and centered, and cast the terminals on the inside.• There is no electrical contact to the housing. Make sure that protective grounding is provided for green/yellow color variants and articles marked with PE. |
|-------------|--|

Dimensions

HDFK 25-VP - Panel feed-through terminal block



0709136

<https://www.phoenixcontact.com/us/products/0709136>

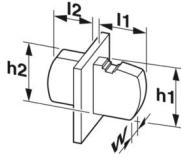
| | |
|---------------------|--|
| Dimensional drawing |  |
| Pitch | 15.1 mm |
| Width [w] | 15 mm |

External dimensions

| | |
|-------------|---------|
| Height [h1] | 48.5 mm |
| Length [l1] | 38.5 mm |

Internal dimensions

| | |
|-------------|-------|
| Height [h2] | 33 mm |
| Length [l2] | 30 mm |

Mechanical tests

Test for conductor damage and slackening

| | |
|---------------|-----------------------|
| Specification | IEC 60947-7-1:2009-04 |
| Result | Test passed |

Pull-out test

| | |
|---|---|
| Specification | IEC 60947-7-1:2009-04 |
| Conductor cross section/conductor type/tractive force setpoint/actual value | 6 mm ² / solid / > 80 N |
| | 10 mm ² / flexible / > 90 N |
| | 35 mm ² / stranded / > 190 N |
| | 25 mm ² / flexible / > 135 N |

Electrical tests

Temperature-rise test

| | |
|-----------------------------------|--------------------------------|
| Specification | IEC 60947-7-1:2009-04 |
| Requirement temperature-rise test | Increase in temperature ≤ 45 K |

Short-time withstand current

| | |
|---------------|-----------------------|
| Specification | IEC 60947-7-1:2009-04 |
|---------------|-----------------------|

Air clearances and creepage distances | 1. Insulation coordination

| | |
|--|---------|
| Insulating material group | I |
| Comparative tracking index (IEC 60112) | CTI 600 |
| Rated insulation voltage (III/3) | 500 V |
| Rated surge voltage (III/3) | 6 kV |
| minimum clearance value - non-homogenous field (III/3) | 5.5 mm |
| minimum creepage distance (III/3) | 6.3 mm |

Environmental and real-life conditions

HDFK 25-VP - Panel feed-through terminal block



0709136

<https://www.phoenixcontact.com/us/products/0709136>

Vibration test

| | |
|------------------------|-----------------------------|
| Specification | IEC 60068-2-6:2007-12 |
| Frequency | 10 - 150 - 10 Hz |
| Sweep speed | 1 octave/min |
| Amplitude | 0.35 mm (10 Hz ... 60.1 Hz) |
| Sweep speed | 5g (60.1 Hz ... 150 Hz) |
| Test duration per axis | 2.5 h |

Glow-wire test

| | |
|------------------|------------------------|
| Specification | IEC 60695-2-11:2014-02 |
| Temperature | 960 °C |
| Time of exposure | 30 s |

Ambient conditions

| | |
|---|---|
| Ambient temperature (operation) | -40 °C ... 100 °C (Depending on the current carrying capacity/derating curve) |
| Ambient temperature (storage/transport) | -40 °C ... 70 °C |
| Relative humidity (storage/transport) | 30 % ... 70 % |
| Ambient temperature (assembly) | -5 °C ... 100 °C |

Packaging specifications

| | |
|-------------------|---------------------|
| Type of packaging | packed in cardboard |
|-------------------|---------------------|

HDFK 25-VP - Panel feed-through terminal block



0709136

<https://www.phoenixcontact.com/us/products/0709136>

Classifications

ECLASS

| | |
|-------------|----------|
| ECLASS-11.0 | 27141134 |
| ECLASS-13.0 | 27141134 |
| ECLASS-12.0 | 27141134 |

ETIM

| | |
|----------|----------|
| ETIM 9.0 | EC001283 |
|----------|----------|

UNSPSC

| | |
|-------------|----------|
| UNSPSC 21.0 | 39121400 |
|-------------|----------|

HDFK 25-VP - Panel feed-through terminal block



0709136

<https://www.phoenixcontact.com/us/products/0709136>

Environmental product compliance

| | |
|------------|---|
| China RoHS | Environmentally friendly use period: unlimited = EFUP-e |
| | No hazardous substances above threshold values |

Phoenix Contact 2024 © - all rights reserved
<https://www.phoenixcontact.com>

Phoenix Contact USA
586 Fulling Mill Road
Middletown, PA 17057, United States
(+717) 944-1300
info@phoenixcon.com