

UCS WM-MP 125-87 7035 - Adapter plate



1225407

<https://www.phoenixcontact.com/us/products/1225407>

Please be informed that the data shown in this PDF document is generated from our online catalog. Please find the complete data in the user documentation. Our general terms of use for downloads are valid.

Adapter for attaching UCS housings in size 125-87 to the wall, to VESA standard brackets, and to wall outlet boxes, housing is snapped on, material: polycarbonate, color: light gray, similar to RAL 7035



Your advantages

- Flexible in use: Only one bracket for the widest range of applications
- No tools required: UCS housings simply snap on
- Wide range of applications: Use on mounts in accordance with the VESA standard and on cavity sockets with a diameter of 60 mm

Commercial data

| | |
|--------------------------------------|---------------|
| Item number | 1225407 |
| Packing unit | 1 pc |
| Minimum order quantity | 1 pc |
| Sales key | AC03 |
| Product key | ACFCAZ |
| GTIN | 4063151317232 |
| Weight per piece (including packing) | 69.35 g |
| Weight per piece (excluding packing) | 48.8 g |
| Customs tariff number | 84879090 |
| Country of origin | CN |

UCS WM-MP 125-87 7035 - Adapter plate

1225407

<https://www.phoenixcontact.com/us/products/1225407>

Technical data

Notes

| | |
|---------|--|
| General | Please observe the assembly instructions available in the download area. |
|---------|--|

Product properties

| | |
|----------------|--------------------|
| Product type | Adapter plate |
| Housing series | UCS |
| Product family | UCS 125-87 |
| Housing type | Universal housings |

Dimensions

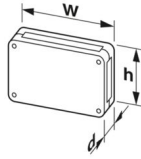
| | |
|---------------------|---|
| Dimensional drawing |  |
| Width | 128.3 mm |
| Height | 94.8 mm |
| Depth | 17.9 mm |

Material specifications

| | |
|--|-----------------------|
| Color (Housing) | light grey (RAL 7035) |
| Flammability rating according to UL 94 | V0 |
| CTI according to IEC 60112 | 225 |
| Insulating material | PC |
| Housing material | PC |

Environmental and real-life conditions

Vibration test

| | |
|------------------------|-----------------------------|
| Specification | IEC 60068-2-6:2007-12 |
| Frequency | 10 - 150 - 10 Hz |
| Sweep speed | 1 octave/min |
| Amplitude | 0.15 mm (10 Hz ... 58.1 Hz) |
| Acceleration | 2g (58.1 Hz ... 150 Hz) |
| Test duration per axis | 2.5 h |
| Test directions | X-, Y- and Z-axis |

Glow-wire test

| | |
|------------------|------------------------|
| Specification | IEC 60695-2-11:2014-02 |
| Temperature | 850 °C |
| Time of exposure | 30 s |

UCS WM-MP 125-87 7035 - Adapter plate



1225407

<https://www.phoenixcontact.com/us/products/1225407>

Thermal stability / ball thrust test

| | |
|---------------|------------------------|
| Specification | IEC 60695-10-2:2014-02 |
| Temperature | 125 °C |
| Test duration | 1 h |
| Force | 20 N |

Mechanical strength / tumbling barrel

| | |
|----------------|------------------------|
| Specification | IEC 60068-2-31:2008-05 |
| Height of fall | 50 cm |
| Frequency | 50 |

Shocks

| | |
|--------------------------------|-----------------------------------|
| Specification | IEC 60068-2-27:2008-02 |
| Pulse shape | Half-sine |
| Acceleration | 15g |
| Shock duration | 11 ms |
| Number of shocks per direction | 3 |
| Test directions | X-, Y- and Z-axis (pos. and neg.) |

Test for substances that would hinder coating with paint or varnish

| | |
|---------------|----------------------|
| Specification | VW PV 3.10.7:2005-02 |
| Result | Test passed |

Ambient conditions

| | |
|---|-------------------|
| Ambient temperature (operation) | -40 °C ... 105 °C |
| Ambient temperature (storage/transport) | -40 °C ... 70 °C |
| Ambient temperature (assembly) | -5 °C ... 100 °C |
| Relative humidity (storage/transport) | 95 % |

Mounting

| | |
|---------------|----------------|
| Mounting type | Screw mounting |
|---------------|----------------|

Packaging specifications

| | |
|-------------------|---------------|
| Type of packaging | Box packaging |
|-------------------|---------------|

UCS WM-MP 125-87 7035 - Adapter plate



1225407

<https://www.phoenixcontact.com/us/products/1225407>

Classifications

ECLASS

| | |
|-------------|----------|
| ECLASS-11.0 | 27182702 |
| ECLASS-13.0 | 27190605 |

ETIM

| | |
|----------|----------|
| ETIM 9.0 | EC001031 |
|----------|----------|

UNSPSC

| | |
|-------------|----------|
| UNSPSC 21.0 | 31261500 |
|-------------|----------|

UCS WM-MP 125-87 7035 - Adapter plate



1225407

<https://www.phoenixcontact.com/us/products/1225407>

Environmental product compliance

| | |
|------------|---|
| China RoHS | Environmentally friendly use period: unlimited = EFUP-e No hazardous substances above threshold values |
|------------|---|

Phoenix Contact 2024 © - all rights reserved
<https://www.phoenixcontact.com>

Phoenix Contact USA
586 Fulling Mill Road
Middletown, PA 17057, United States
(+717) 944-1300
info@phoenixcon.com