

ECS-P-64X80-L-UV-B GY - Front plate



1186436

<https://www.phoenixcontact.com/us/products/1186436>

Please be informed that the data shown in this PDF document is generated from our online catalog. Please find the complete data in the user documentation. Our general terms of use for downloads are valid.

Snap-in locking blank faceplate of the ECS Family. IP66/67/69 rated when mated with associated enclosure. Color: Grey (7042), Width: 97 mm, Height: 15 mm, Depth: 42 mm



Your advantages

- Ultra-compact housing design for a wide range of applications
- Housing design supports the installation of a range of PCB thicknesses for high application diversity
- Optional accessories for wall and mast mounting
- Proven PCB connection technology
- Integrated tamper protection
- Effective protection of electronics against thermal and mechanical influences
- Suitable for outdoor/indoor applications

Commercial data

Item number	1186436
Packing unit	5 pc
Minimum order quantity	5 pc
Sales key	AC04
Product key	ACFDAB
GTIN	4063151226275
Weight per piece (including packing)	29.8 g
Weight per piece (excluding packing)	29 g
Customs tariff number	84879090
Country of origin	US

ECS-P-64X80-L-UV-B GY - Front plate

1186436

<https://www.phoenixcontact.com/us/products/1186436>

Technical data

Notes

General	Refer to the data sheet for the range in the download area.
---------	---

Product properties

Product type	Front plate
Housing series	ECS
Housing type	outdoor housings

Dimensions

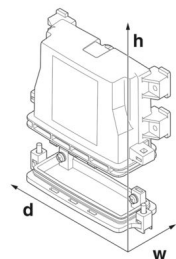
Dimensional drawing	
Width	97 mm
Height	15 mm
Depth	42 mm

PCB design

PCB thickness	1.57 mm ... 2.36 mm
---------------	---------------------

Material specifications

Color (Housing)	gray (RAL 7042)
Flammability rating according to UL 94	V0
Surface characteristics	untreated
Impact strength	IK08
Housing material	PC (polycarbonate)

Environmental and real-life conditions

Vibration test

Specification	IEC 60068-2-6:2007-12
Frequency	10 - 2000 - 10 Hz
Sweep speed	1 octave/min
Acceleration	15g (61.6 Hz ... 2000 Hz)
Test duration per axis	2.5 h
Test directions	X-, Y- and Z-axis

Glow-wire test

Specification	IEC 60695-2-11:2014-02
---------------	------------------------

ECS-P-64X80-L-UV-B GY - Front plate



1186436

<https://www.phoenixcontact.com/us/products/1186436>

Temperature	850 °C
Time of exposure	30 s

Mechanical strength / tumbling barrel

Specification	IEC 60068-2-31:2008-05
Height of fall	50 cm
Frequency	50

Shocks

Specification	IEC 60068-2-27:2008-02
Pulse shape	Semi-sinusoidal
Acceleration	50g
Shock duration	11 ms
Number of shocks per direction	3
Test directions	X-, Y- and Z-axis (pos. and neg.)

Salt spray test

Specification	DIN EN 60068-2-11:2000-02
Test duration	96 h

Test for substances that would hinder coating with paint or varnish

Specification	VDMA 24364:2018-05
Result	Test passed

Degree of protection (IP code)

Specification	IEC 60529:1989-11 + AMD 1:1999-11 + AMD 2:2013-08
Result, degree of protection, IP code	IP66/IP68 (2 m/24 h)

Ambient conditions

Max. NEMA code to attain	6
Impact strength	IK08
Ambient temperature (operation)	-40 °C ... 100 °C
Ambient temperature (storage/transport)	-40 °C ... 100 °C

PCB data

Number of PCB holders	1
Thickness of the PCB	1.57 mm ... 2.36 mm

Mounting

Mounting type	Mechanical latch to base
---------------	--------------------------

ECS-P-64X80-L-UV-B GY - Front plate



1186436

<https://www.phoenixcontact.com/us/products/1186436>

Classifications

ECLASS

ECLASS-11.0	27182702
ECLASS-13.0	27190603

ETIM

ETIM 9.0	EC001031
----------	----------

UNSPSC

UNSPSC 21.0	31261500
-------------	----------

ECS-P-64X80-L-UV-B GY - Front plate



1186436

<https://www.phoenixcontact.com/us/products/1186436>

Environmental product compliance

China RoHS	Environmentally friendly use period: unlimited = EFUP-e
	No hazardous substances above threshold values

Phoenix Contact 2024 © - all rights reserved
<https://www.phoenixcontact.com>

Phoenix Contact USA
586 Fulling Mill Road
Middletown, PA 17057, United States
(+717) 944-1300
info@phoenixcon.com