

# ECS-P-64X80-S-UV-B GY - Front plate



1186435

<https://www.phoenixcontact.com/us/products/1186435>

Please be informed that the data shown in this PDF document is generated from our online catalog. Please find the complete data in the user documentation. Our general terms of use for downloads are valid.

Screw locking blank faceplate of the ECS Family. IP66/67/69 rated when mated with associated enclosure. Color: Grey (7042), Width: 97 mm, Height: 15 mm, Depth: 42 mm



## Your advantages

- Ultra-compact housing design for a wide range of applications
- Housing design supports the installation of a range of PCB thicknesses for high application diversity
- Optional accessories for wall and mast mounting
- Proven PCB connection technology
- Integrated tamper protection
- Suitable for outdoor/indoor applications

## Commercial data

Item number	1186435
Packing unit	5 pc
Minimum order quantity	5 pc
Sales key	AC04
Product key	ACFDAB
GTIN	4063151227371
Weight per piece (including packing)	29 g
Weight per piece (excluding packing)	29 g
Customs tariff number	84879090
Country of origin	US

# ECS-P-64X80-S-UV-B GY - Front plate

1186435

<https://www.phoenixcontact.com/us/products/1186435>

## Technical data

### Product properties

Product type	Front plate
Housing series	ECS
Housing type	outdoor housings

### Dimensions

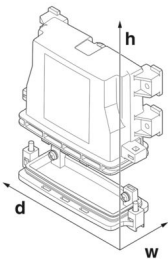
Dimensional drawing	
Width	97 mm
Height	15 mm
Depth	42 mm

### PCB design

PCB thickness	1.57 mm ... 2.36 mm
---------------	---------------------

### Material specifications

Color (Housing)	gray (RAL 7042)
Flammability rating according to UL 94	V0
Surface characteristics	untreated
Impact strength	IK08
Housing material	PC (polycarbonate)

### Environmental and real-life conditions

#### Vibration test

Specification	IEC 60068-2-6:2007-12
Frequency	10 - 2000 - 10 Hz
Sweep speed	1 octave/min
Acceleration	15g (61.6 Hz ... 2000 Hz)
Test duration per axis	2.5 h
Test directions	X-, Y- and Z-axis

#### Glow-wire test

Specification	IEC 60695-2-11:2014-02
Temperature	850 °C
Time of exposure	30 s

# ECS-P-64X80-S-UV-B GY - Front plate



1186435

<https://www.phoenixcontact.com/us/products/1186435>

## Mechanical strength / tumbling barrel

Specification	IEC 60068-2-31:2008-05
Height of fall	50 cm
Frequency	50

## Shocks

Specification	IEC 60068-2-27:2008-02
Pulse shape	Semi-sinusoidal
Acceleration	50g
Shock duration	11 ms
Number of shocks per direction	20
Test directions	X-, Y- and Z-axis (pos. and neg.)

## Salt spray test

Specification	DIN EN 60068-2-11:2000-02
Test duration	96 h

## Test for substances that would hinder coating with paint or varnish

Specification	VDMA 24364:2018-05
Result	Test passed

## Degree of protection (IP code)

Specification	IEC 60529:1989-11 + AMD 1:1999-11 + AMD 2:2013-08
Result, degree of protection, IP code	IP69 (2 m / 24 h)

## Ambient conditions

Max. NEMA code to attain	6
Impact strength	IK08
Ambient temperature (operation)	-40 °C ... 100 °C
Ambient temperature (storage/transport)	-40 °C ... 100 °C

## PCB data

Number of PCB holders	1
Thickness of the PCB	1.57 mm ... 2.36 mm

## Mounting

Mounting type	Screw locking mechanism
---------------	-------------------------

# ECS-P-64X80-S-UV-B GY - Front plate



1186435

<https://www.phoenixcontact.com/us/products/1186435>

## Classifications

### ECLASS

ECLASS-11.0	27182702
ECLASS-13.0	27190603

### ETIM

ETIM 9.0	EC001031
----------	----------

### UNSPSC

UNSPSC 21.0	31261500
-------------	----------

# ECS-P-64X80-S-UV-B GY - Front plate



1186435

<https://www.phoenixcontact.com/us/products/1186435>

## Environmental product compliance

China RoHS	Environmentally friendly use period: unlimited = EFUP-e No hazardous substances above threshold values
------------	---

Phoenix Contact 2024 © - all rights reserved  
<https://www.phoenixcontact.com>

Phoenix Contact USA  
586 Fulling Mill Road  
Middletown, PA 17057, United States  
(+717) 944-1300  
[info@phoenixcon.com](mailto:info@phoenixcon.com)