

DMCC 0,5/ 2-ST-SH 7,0-2,54 - PCB connector



1128660

<https://www.phoenixcontact.com/us/products/1128660>

Please be informed that the data shown in this PDF document is generated from our online catalog. Please find the complete data in the user documentation. Our general terms of use for downloads are valid.



PCB connector, nominal cross section: 0.34 mm², color: black, nominal current: 5 A, rated voltage (III/2): 160 V, contact connection type: Socket, number of potentials: 4, number of rows: 2, number of positions: 2, number of connections: 4, product range: DMCC 0,5/..-ST-SH, pitch: 2.54 mm, connection method: Crimp connection, conductor/PCB connection direction: 0 °, plug-in system: COMBICON DFMC 0,5 shielded, Electrical properties: shielded, locking: shielded connection, mounting: without, type of packaging: packed in cardboard, Suitable for CAT5

Your advantages

- Cost-effective connection of crimped conductors in large quantities
- Gold-plated contacts ensure transfer quality remains stable over the long term
- Contacts arranged in a double row enable high packing density in a compact area
- Tools for manual and automatic crimping available as an option

Commercial data

Item number	1128660
Packing unit	100 pc
Minimum order quantity	100 pc
Sales key	AA01
Product key	AAAIAA
GTIN	4063151057138
Weight per piece (including packing)	2.2 g
Weight per piece (excluding packing)	2.2 g
Customs tariff number	85366990
Country of origin	CN

DMCC 0,5/ 2-ST-SH 7,0-2,54 - PCB connector



1128660

<https://www.phoenixcontact.com/us/products/1128660>

Technical data

Product properties

Product line	COMBICON Connectors XS
Product type	PCB connector
Product family	DMCC 0,5/..-ST-SH
Number of positions	2
Pitch	2.54 mm
Number of connections	4
Number of rows	2
Number of potentials	4
Electrical characteristic	shielded

Electrical properties

Nominal current I_N	5 A
Nominal voltage U_N	160 V
Degree of pollution	3
Contact resistance	4.8 m Ω
Rated voltage (III/3)	50 V
Rated surge voltage (III/3)	2.5 kV
Rated voltage (III/2)	160 V
Rated surge voltage (III/2)	2.5 kV
Rated voltage (II/2)	250 V
Rated surge voltage (II/2)	2.5 kV
Electrical characteristic	shielded

Connection data

Interlock

Locking type	shielded connection
Mounting flange	without

Conductor connection

Connection method	Crimp connection
Conductor/PCB connection direction	0 °
Conductor cross section AWG	26 ... 22
Stripping length	4.1 mm ... 4.5 mm

Material specifications

Material data - housing

Color (Housing)	black (9005)
Insulating material	PA
Insulating material group	I
CTI according to IEC 60112	600

DMCC 0,5/ 2-ST-SH 7,0-2,54 - PCB connector



1128660

<https://www.phoenixcontact.com/us/products/1128660>

Flammability rating according to UL 94	V0
Glow wire flammability index GWFI according to EN 60695-2-12	850
Glow wire ignition temperature GWIT according to EN 60695-2-13	775
Temperature for the ball pressure test according to EN 60695-10-2	125 °C

Dimensions

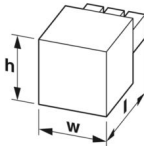
Dimensional drawing	
Pitch	2.54 mm
Width [w]	7.1 mm
Height [h]	7.4 mm
Length [l]	26.5 mm

Notes

General	The item is qualified for CAT5 Ethernet applications. For this reason, it is suited for use in IoT devices.
---------	---

Mechanical tests

Tensile strength of crimp connections

Result	Test passed
Conductor cross section/conductor type/tractive force setpoint/actual value	AWG 22 / flexible / > 40 N

Insertion and withdrawal forces

Result	Test passed
No. of cycles	100
Insertion strength per pos. approx.	3 N
Withdraw strength per pos. approx.	3 N

Resistance of inscriptions

Specification	IEC 60068-2-70:1995-12
Result	Test passed

Polarization and coding

Specification	IEC 60512-13-5:2006-02
Result	Test passed

Visual inspection

Specification	IEC 60512-1-1:2002-02
Result	Test passed

Dimension check

DMCC 0,5/ 2-ST-SH 7,0-2,54 - PCB connector



1128660

<https://www.phoenixcontact.com/us/products/1128660>

Specification	IEC 60512-1-2:2002-02
Result	Test passed

Environmental and real-life conditions

Vibration test

Specification	IEC 60068-2-6:2007-12
Frequency	10 - 150 - 10 Hz
Sweep speed	1 octave/min
Amplitude	0.35 mm (10 Hz ... 60.1 Hz)
Sweep speed	50 m/s ² (60.1 Hz ... 150 Hz)
Test duration per axis	2.5 h

Durability test

Specification	IEC 60512-9-1:2010-03
Impulse withstand voltage at sea level	2.95 kV
Contact resistance R ₁	4.8 mΩ
Contact resistance R ₂	4.9 mΩ
Insertion/withdrawal cycles	100
Insulation resistance, neighboring positions	> 5 MΩ

Climatic test

Specification	ISO 6988:1985-02
Corrosive stress	0.2 dm ³ SO ₂ on 300 dm ³ /40 °C/1 cycle
Thermal stress	80 °C/168 h
Power-frequency withstand voltage	1.39 kV

Shocks

Specification	IEC 60068-2-27:2008-02
Pulse shape	Semi-sinusoidal
Acceleration	350 m/s ²
Shock duration	11 ms
Test directions	X-, Y- and Z-axis (pos. and neg.)

Ambient conditions

Ambient temperature (storage/transport)	-30 °C ... 70 °C
Relative humidity (storage/transport)	30 % ... 70 %
Ambient temperature (assembly)	-5 °C ... 80 °C
Ambient temperature (installation)	-40 °C ... 80 °C (dependent on the derating curve)
Ambient temperature (mobile installation)	-30 °C 80 °C dependent on the derating curve

Electrical tests

Thermal test | Test group C

Specification	IEC 60512-5-1:2002-02
Tested number of positions	2

DMCC 0,5/ 2-ST-SH 7,0-2,54 - PCB connector



1128660

<https://www.phoenixcontact.com/us/products/1128660>

Insulation resistance

Specification	IEC 60512-3-1:2002-02
Insulation resistance, neighboring positions	> 5 MΩ

Air clearances and creepage distances |

Specification	IEC 60664-1:2007-04
Insulating material group	I
Comparative tracking index (IEC 60112)	CTI 600
Rated insulation voltage (III/3)	50 V
Rated surge voltage (III/3)	2.5 kV
minimum clearance value - non-homogenous field (III/3)	1.5 mm
minimum creepage distance (III/3)	1.5 mm
Rated insulation voltage (III/2)	160 V
Rated surge voltage (III/2)	2.5 kV
minimum clearance value - non-homogenous field (III/2)	1.5 mm
minimum creepage distance (III/2)	1.5 mm
Rated insulation voltage (II/2)	250 V
Rated surge voltage (II/2)	2.5 kV
minimum clearance value - non-homogenous field (II/2)	1.5 mm
minimum creepage distance (II/2)	1.25 mm

Packaging specifications

Type of packaging	packed in cardboard
-------------------	---------------------

DMCC 0,5/ 2-ST-SH 7,0-2,54 - PCB connector



1128660

<https://www.phoenixcontact.com/us/products/1128660>

Classifications

ECLASS

ECLASS-11.0	27460202
ECLASS-12.0	27460202
ECLASS-13.0	27460202

ETIM

ETIM 9.0	EC002638
----------	----------

UNSPSC

UNSPSC 21.0	39121400
-------------	----------

DMCC 0,5/ 2-ST-SH 7,0-2,54 - PCB connector



1128660

<https://www.phoenixcontact.com/us/products/1128660>

Environmental product compliance

China RoHS	Environmentally friendly use period: unlimited = EFUP-e
	No hazardous substances above threshold values

Phoenix Contact 2024 © - all rights reserved
<https://www.phoenixcontact.com>

Phoenix Contact USA
586 Fulling Mill Road
Middletown, PA 17057, United States
(+717) 944-1300
info@phoenixcon.com