

# Antenna - TC ANT MOBILE CABINET 10M - 1046361

Please be informed that the data shown in this PDF Document is generated from our Online Catalog. Please find the complete data in the user's documentation. Our General Terms of Use for Downloads are valid (<http://phoenixcontact.com/download>)

Cellular antenna for mounting on the control cabinet, 10 m antenna cable with SMA circular connector



## Key Commercial Data

Packing unit	1
GTIN	 4 055626 640631
GTIN	4055626640631
Custom tariff number	85177000

## Technical data

### Dimensions

Height	15.9 mm
Diameter	77.4 mm
Fixed cable length	10.00 m

### Ambient conditions

Degree of protection	IP69K (Assembled)
Ambient temperature (operation)	-40 °C ... 85 °C

### General

With connecting cable	yes
Frequency range	850 MHz
	900 MHz
	1800 MHz
	1900 MHz

# Antenna - TC ANT MOBILE CABINET 10M - 1046361

## Technical data

### General

	2100 MHz
Polarization	vertical
Gain	typ. 2.2 dBi
Connection method	SMA (male)
Fixed cable length	10.00 m
Material	TPE (Seal)
Housing material	ABS
Mounting type	Control cabinet

### Environmental Product Compliance

China RoHS	Environmentally friendly use period: unlimited = EFUP-e
	No hazardous substances above threshold values

## Drawings

Dimensional drawing

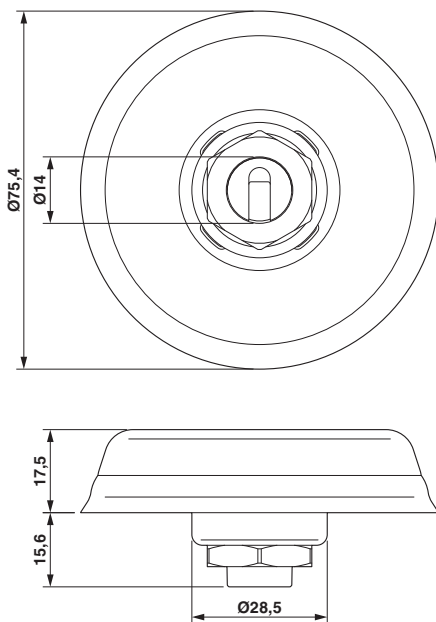

Schematic diagram

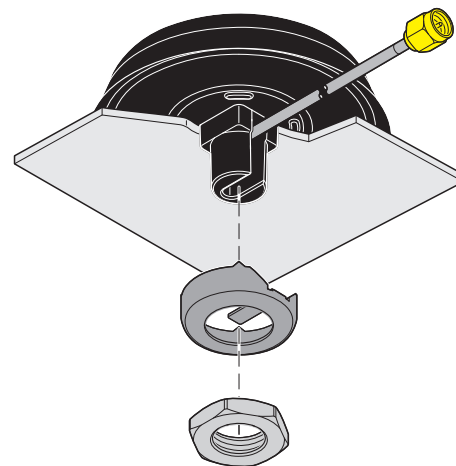

Mounting on the control cabinet

## Classifications

eCl@ss

eCl@ss 10.0.1	19070105
eCl@ss 11.0	19070105

## Antenna - TC ANT MOBILE CABINET 10M - 1046361

### Classifications

#### eCl@ss

eCl@ss 7.0	19070105
eCl@ss 9.0	19070105

#### ETIM

ETIM 6.0	EC001698
ETIM 7.0	EC001698