

# EH 22,5 F-B/ABS-PC BK9005 - Mounting base housing



1071149

<https://www.phoenixcontact.com/us/products/1071149>

Please be informed that the data shown in this PDF document is generated from our online catalog. Please find the complete data in the user documentation. Our general terms of use for downloads are valid.

DIN rail housing, Lower housing part with base latch, flat design, width: 22.6 mm, height: 75 mm, depth: 30.3 mm, color: black (similar RAL 9005)



## Your advantages

- DIN rail or wall mounting for application-specific device attachment
- Easy design-in, thanks to variable housing form factor
- Complete flexibility, thanks to PCBs with horizontal, frontal, and orthogonal orientation to the front of the device
- Three cover versions for individual PCB connections
- Integration of a wide variety of PCB connection technologies for a functional device design

## Commercial data

Item number	1071149
Packing unit	10 pc
Minimum order quantity	1 pc
Product key	ACHCHB
GTIN	4055626752723
Weight per piece (including packing)	68.3 g
Weight per piece (excluding packing)	66.92 g
Country of origin	IN

# EH 22,5 F-B/ABS-PC BK9005 - Mounting base housing

1071149

<https://www.phoenixcontact.com/us/products/1071149>

## Technical data

### Notes

General	Refer to the data sheet for the range in the download area.
---------	---

### Product properties

Product type	Enclosure bottom part
Housing series	EH
Product family	EH 22,5-..
Type	Lower housing part with base latch, flat design
Housing type	DIN rail housing
Ventilation openings present	no

### Dimensions

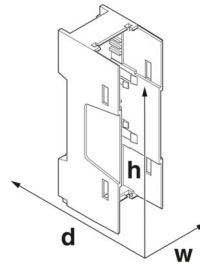
Dimensional drawing	
Width	22.6 mm
Height	75 mm
Depth	30.3 mm
Depth from top edge of DIN rail to support point on upper part	26 mm

### PCB design

PCB thickness	1.4 mm ... 1.8 mm
---------------	-------------------

### Material specifications

Color (Housing)	black (RAL 9005)
Flammability rating according to UL 94	V0
Surface characteristics	untreated
Housing material	ABS-PC

### Environmental and real-life conditions

#### Vibration test

Specification	IEC 60068-2-6:2007-12
Frequency	10 - 150 - 10 Hz
Sweep speed	1 octave/min
Amplitude	0.15 mm (10 Hz ... 58.1 Hz)
Acceleration	2g (58.1 Hz ... 150 Hz)

# EH 22,5 F-B/ABS-PC BK9005 - Mounting base housing



1071149

<https://www.phoenixcontact.com/us/products/1071149>

Test duration per axis	2.5 h
Test directions	X-, Y- and Z-axis

## Glow-wire test

Specification	IEC 60695-2-11:2014-02
Temperature	850 °C
Time of exposure	30 s

## Thermal stability / ball thrust test

Specification	IEC 60695-10-2:2014-02
Temperature	80 °C
Test duration	1 h
Force	20 N

## Mechanical strength / tumbling barrel

Specification	IEC 60998-1:2002-12
Height of fall	50 cm
Frequency	10

## Shocks

Specification	IEC 60068-2-27:2008-02
Pulse shape	Half-sine
Acceleration	15g
Shock duration	11 ms
Number of shocks per direction	3
Test directions	X-, Y- and Z-axis (pos. and neg.)

## Degree of protection (IP code)

Specification	IEC 60529:1989-11 + AMD 1:1999-11 + AMD 2:2013-08
---------------	---

## Ambient conditions

Max. IP code to attain	IP20
Ambient temperature (operation)	-40 °C ... 80 °C (depending on power dissipation)
Ambient temperature (storage/transport)	-40 °C ... 55 °C
Ambient temperature (assembly)	-5 °C ... 80 °C
Relative humidity (storage/transport)	95 %

## PCB data

Type of PCB mount	Latching
Thickness of the PCB	1.4 mm ... 1.8 mm

## Mounting

Mounting type	DIN rail mounting/wall mounting (with optional base latch)
Mounting position	Vertical (horizontal DIN rail)

## Packaging specifications

Type of packaging	packed in cardboard
-------------------	---------------------

# EH 22,5 F-B/ABS-PC BK9005 - Mounting base housing



1071149

<https://www.phoenixcontact.com/us/products/1071149>

Outer packaging type	Carton
----------------------	--------

# EH 22,5 F-B/ABS-PC BK9005 - Mounting base housing



1071149

<https://www.phoenixcontact.com/us/products/1071149>

## Classifications

### ECLASS

ECLASS-11.0	27182702
ECLASS-13.0	27190601

### ETIM

ETIM 9.0	EC001031
----------	----------

### UNSPSC

UNSPSC 21.0	31261500
-------------	----------

# EH 22,5 F-B/ABS-PC BK9005 - Mounting base housing



1071149

<https://www.phoenixcontact.com/us/products/1071149>

## Environmental product compliance

China RoHS	Environmentally friendly use period: unlimited = EFUP-e No hazardous substances above threshold values
------------	---

Phoenix Contact 2024 © - all rights reserved  
<https://www.phoenixcontact.com>

Phoenix Contact USA  
586 Fulling Mill Road  
Middletown, PA 17057, United States  
(+717) 944-1300  
[info@phoenixcon.com](mailto:info@phoenixcon.com)