

HC-M-D15-MF-HB - Module carrier frame



1062122

<https://www.phoenixcontact.com/us/products/1062122>

Please be informed that the data shown in this PDF document is generated from our online catalog. Please find the complete data in the user documentation. Our general terms of use for downloads are valid.

Module carrier frame, size: D15, 0.14 mm² ... 2.5 mm², application: Module carrier frame, for size D15 housings



Commercial data

Item number	1062122
Packing unit	1 pc
Minimum order quantity	1 pc
Sales key	BF62
Product key	BF7ACD
GTIN	4055626718040
Weight per piece (including packing)	45 g
Weight per piece (excluding packing)	43 g
Customs tariff number	85389099
Country of origin	CN

HC-M-D15-MF-HB - Module carrier frame



1062122

<https://www.phoenixcontact.com/us/products/1062122>

Technical data

Notes

General	for modular contact inserts with a width of 14.6 mm in conjunction with size D15 housings.
---------	--

Product properties

Type	D15
Product type	Module carrier frame
Application	Module carrier frame
Number of module slots	1

Connection data

Conductor connection

Conductor cross section	0.14 mm ² ... 2.5 mm ² (applies to stranded conductors with ferrules)
Connection cross section AWG	24 ... 14

Dimensions

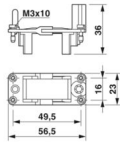
Dimensional drawing	
Width	23 mm
Height	36 mm
Length	56.5 mm

Material specifications

Contact surface material	Ni
Contact carrier material	Die-cast zinc alloy

Mechanical properties

Mechanical data

Insertion/withdrawal cycles	≥ 500
-----------------------------	-------

Environmental and real-life conditions

Ambient conditions

Ambient temperature (operation)	-40 °C ... 125 °C
---------------------------------	-------------------

Mounting

Assembly instructions	Maximum allowable conductor cross section for the modules used: 2.5 mm ²
-----------------------	---

HC-M-D15-MF-HB - Module carrier frame



1062122

<https://www.phoenixcontact.com/us/products/1062122>

Classifications

ECLASS

ECLASS-11.0	27440206
ECLASS-12.0	27440206
ECLASS-13.0	27440206

ETIM

ETIM 9.0	EC002312
----------	----------

UNSPSC

UNSPSC 21.0	31261500
-------------	----------

HC-M-D15-MF-HB - Module carrier frame



1062122

<https://www.phoenixcontact.com/us/products/1062122>

Environmental product compliance

China RoHS	Environmentally friendly use period: unlimited = EFUP-e No hazardous substances above threshold values
------------	---

Phoenix Contact 2024 © - all rights reserved
<https://www.phoenixcontact.com>

Phoenix Contact USA
586 Fulling Mill Road
Middletown, PA 17057, United States
(+717) 944-1300
info@phoenixcon.com