

EO-CF/UT - Socket



0804024

<https://www.phoenixcontact.com/us/products/0804024>

Please be informed that the data shown in this PDF document is generated from our online catalog. Please find the complete data in the user documentation. Our general terms of use for downloads are valid.



Socket, Pin connector pattern type CF, Screw connection, gray, for mounting on a DIN rail in the service interface or direct mounting, 250 V AC, 16 A, -20 °C, 60 °C, VDE 0620-1

Commercial data

Item number	0804024
Packing unit	5 pc
Minimum order quantity	5 pc
Sales key	BE76
Product key	BE7611
Catalog page	Page 562 (C-3-2019)
GTIN	4055626225661
Weight per piece (including packing)	75.52 g
Weight per piece (excluding packing)	73 g
Customs tariff number	85366990
Country of origin	PL

Technical data

Product properties

Product type	Socket
Country ID	Germany

Electrical properties

Nominal voltage U_N	250 V AC (50 Hz)
Nominal current I_N	16 A

Connection data

Connection method	Screw connection
Stripping length	8 mm
Tightening torque	0.5 ... 0.6 Nm
Conductor cross section flexible	0.2 mm ² ... 2.5 mm ²
Conductor cross section rigid	0.2 mm ² ... 4 mm ²
Cross section AWG	24 ... 12
Screw thread	M3

Signaling

Status display	No
----------------	----

Dimensions

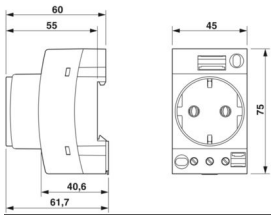
Dimensional drawing	
Width	45 mm
Height	75 mm
Depth	75 mm

Material specifications

Color	gray
Flammability rating according to UL 94	V0
Insulating material	PA
Contact material	CuZn37
Static insulating material application in cold	-60 °C
Relative insulation material temperature index (Elec., UL 746 B)	130 °C
Fire protection for rail vehicles (DIN EN 45545-2) R22	HL 1 - HL 3
Fire protection for rail vehicles (DIN EN 45545-2) R23	HL 1 - HL 3
Fire protection for rail vehicles (DIN EN 45545-2) R24	HL 1 - HL 3

EO-CF/UT - Socket



0804024

<https://www.phoenixcontact.com/us/products/0804024>

Fire protection for rail vehicles (DIN EN 45545-2) R26	HL 1 - HL 3
Surface flammability NFPA 130 (ASTM E 162)	passed
Specific optical density of smoke NFPA 130 (ASTM E 662)	passed
Smoke gas toxicity NFPA 130 (SMP 800C)	passed

Connector

Type of plug	Pin connector pattern type CF
--------------	-------------------------------

Environmental and real-life conditions

Ambient conditions

Degree of protection	IP20
Ambient temperature (operation)	-20 °C ... 60 °C (max. short-term operating temperature RTI Elec.)
Ambient temperature (storage/transport)	-25 °C ... 60 °C (for a short time, not exceeding 24 h, -60 °C to +70 °C)
Permissible humidity (storage/transport)	30 % ... 70 %

Standards and regulations

Standards

Standards/regulations	VDE 0620-1
-----------------------	------------

Mounting

Mounting type	for mounting on a DIN rail in the service interface or direct mounting
---------------	--

EO-CF/UT - Socket



0804024

<https://www.phoenixcontact.com/us/products/0804024>

Classifications

ECLASS

ECLASS-11.0	27142305
ECLASS-12.0	27142305
ECLASS-13.0	27142305

ETIM

ETIM 9.0	EC001663
----------	----------

UNSPSC

UNSPSC 21.0	39121400
-------------	----------

EO-CF/UT - Socket



0804024

<https://www.phoenixcontact.com/us/products/0804024>

Environmental product compliance

China RoHS	Environmentally friendly use period: unlimited = EFUP-e No hazardous substances above threshold values
------------	---

Phoenix Contact 2024 © - all rights reserved
<https://www.phoenixcontact.com>

Phoenix Contact USA
586 Fulling Mill Road
Middletown, PA 17057, United States
(+717) 944-1300
info@phoenixcon.com