

UCS 145-125-H-CCD 9005 - Universal housings



2203451

<https://www.phoenixcontact.com/us/products/2203451>

Please be informed that the data shown in this PDF document is generated from our online catalog. Please find the complete data in the user documentation. Our general terms of use for downloads are valid.



Complete housing for PCBs, fixed to the corner inlays, includes housing half shells, side panels closed, corner inlays with PCB attachment, screws for housing and PCB attachment, black housing with turquoise blue corner inlays

Your advantages

- High degree of application flexibility, thanks to the modular housing design
- Flexible PCB attachment, adapts to virtually all form factors
- Practical customization options
- Reduced logistics outlay, thanks to components which are compatible with one another

Commercial data

Item number	2203451
Packing unit	1 pc
Minimum order quantity	1 pc
Sales key	AC03
Product key	ACFCAA
GTIN	4055626403380
Weight per piece (including packing)	439.3 g
Weight per piece (excluding packing)	242.26 g
Customs tariff number	84879090
Country of origin	DE

UCS 145-125-H-CCD 9005 - Universal housings



2203451

<https://www.phoenixcontact.com/us/products/2203451>

Technical data

Notes

General	The housing can be opened a maximum of 10 times.
General	Attach the adhesive pads: Make sure that the surface of the housing is clean, dry, and free of grease. Temperature range: +18°C ... +30°C / Closing pressure force: 60 N / Closing pressure time: 3 s

Product properties

Product type	Complete housing
Housing series	UCS
Product family	UCS 145-125-H
Type	Tall design (CCD)
Housing type	Universal housings
Ventilation openings present	no

Dimensions

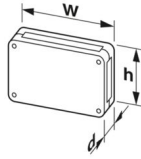
Dimensional drawing	
Width	145 mm
Height	125 mm
Depth	67 mm
Dimensions	120 mm x 100 mm (Maximum circuit board dimensions)

PCB design

PCB thickness	0.8 mm ... 3 mm
---------------	-----------------

Material specifications

Color (Housing)	black (RAL 9005)
Color (Corner inlay)	turquoise green (RAL 5018)
Flammability rating according to UL 94	V0
CTI according to IEC 60112	225
Insulating material	PC
Surface characteristics	untreated
Housing material	PC

Environmental and real-life conditions

Power dissipation single housing for 20 °C

Ambient temperature	20 °C
Reduction factor	1

UCS 145-125-H-CCD 9005 - Universal housings



2203451

<https://www.phoenixcontact.com/us/products/2203451>

Mounting position	vertical
Power dissipation	13.5 W

Power dissipation single housing for 30 °C

Ambient temperature	30 °C
Reduction factor	0.84
Mounting position	vertical
Power dissipation	11.3 W

Power dissipation single housing for 40 °C

Ambient temperature	40 °C
Reduction factor	0.66
Mounting position	vertical
Power dissipation	9 W

Power dissipation single housing for 50 °C

Ambient temperature	50 °C
Reduction factor	0.54
Mounting position	vertical
Power dissipation	7.3 W

Power dissipation single housing for 60 °C

Ambient temperature	60 °C
Reduction factor	0.4
Mounting position	vertical
Power dissipation	5.5 W

Vibration test

Specification	IEC 60068-2-6:2007-12
Frequency	10 - 150 - 10 Hz
Sweep speed	1 octave/min
Amplitude	0.15 mm (10 Hz ... 58.1 Hz)
Acceleration	2g (58.1 Hz ... 150 Hz)
Test duration per axis	2.5 h
Test directions	X-, Y- and Z-axis

Glow-wire test

Specification	IEC 60695-2-11:2014-02
Temperature	850 °C
Time of exposure	30 s

Thermal stability / ball thrust test

Specification	IEC 60695-10-2:2014-02
Temperature	125 °C
Test duration	1 h
Force	20 N

Mechanical strength / tumbling barrel

UCS 145-125-H-CCD 9005 - Universal housings



2203451

<https://www.phoenixcontact.com/us/products/2203451>

Specification	IEC 60068-2-31:2008-05
Height of fall	50 cm
Frequency	50

Shocks

Specification	IEC 60068-2-27:2008-02
Pulse shape	Half-sine
Acceleration	15g
Shock duration	11 ms
Number of shocks per direction	3
Test directions	X-, Y- and Z-axis (pos. and neg.)

Test for substances that would hinder coating with paint or varnish

Specification	VW PV 3.10.7:2005-02
Result	Test passed

Degree of protection (IP code)

Specification	IEC 60529:1989-11 + AMD 1:1999-11 + AMD 2:2013-08
Result, degree of protection, IP code	IP40

Ambient conditions

Max. IP code to attain	IP40
Ambient temperature (operation)	-40 °C ... 105 °C (depending on power dissipation)
Ambient temperature (storage/transport)	-40 °C ... 55 °C
Ambient temperature (assembly)	-5 °C ... 100 °C
Relative humidity (storage/transport)	80 %

PCB data

Number of PCB holders	1
Type of PCB mount	Bolt mounting
Total PCB surface	12000 mm ²
Thickness of the PCB	0.8 mm ... 3 mm
Note on PCB holders	This product is prepared for a printed-circuit board. Additional printed-circuit boards can be mounted using adhesive pads (accessories).

Mounting

Mounting type	Screw mounting
Mounting position	any
Tightening torque / speed	Screw connection between housing halves: 1.2 Nm-1.4 Nm / 500 rpm-1000 rpm Mounting of PCB on corner feeder: 0.4 Nm-0.5 Nm / 500 rpm-1000 rpm

Packaging specifications

Type of packaging	Box packaging
-------------------	---------------

UCS 145-125-H-CCD 9005 - Universal housings



2203451

<https://www.phoenixcontact.com/us/products/2203451>

Classifications

ECLASS

ECLASS-11.0	27182702
ECLASS-13.0	27190603

ETIM

ETIM 9.0	EC001031
----------	----------

UNSPSC

UNSPSC 21.0	31261500
-------------	----------

UCS 145-125-H-CCD 9005 - Universal housings



2203451

<https://www.phoenixcontact.com/us/products/2203451>

Environmental product compliance

China RoHS	Environmentally friendly use period: unlimited = EFUP-e
	No hazardous substances above threshold values

Phoenix Contact 2024 © - all rights reserved
<https://www.phoenixcontact.com>

Phoenix Contact USA
586 Fulling Mill Road
Middletown, PA 17057, United States
(+717) 944-1300
info@phoenixcon.com