

EV-T2SF-EM - Fixing frame

1627637

<https://www.phoenixcontact.com/us/products/1627637>

Please be informed that the data shown in this PDF document is generated from our online catalog. Please find the complete data in the user documentation. Our general terms of use for downloads are valid.

CHARX connect basic, Fixing frame, Accessories, for attaching to infrastructure charging sockets, Type 2, IEC 62196-2, Front mounting, housing: black, Without logo



Product description

Fixing frame for Infrastructure Socket Outlet

Your advantages

- Developed and produced in accordance with the IATF 16949 automotive standard and ISO 9001
- Individual branding, thanks to the use your own logo
- Reliable protection of your socket outlet from weather and vandalism

Commercial data

Item number	1627637
Packing unit	1 pc
Minimum order quantity	1 pc
Sales key	EM01
Product key	XWBAFC
Catalog page	Page 46 (C-7-2019)
GTIN	4055626346106
Weight per piece (including packing)	40.467 g
Weight per piece (excluding packing)	38.9 g
Customs tariff number	39269097
Country of origin	PL

EV-T2SF-EM - Fixing frame

1627637

<https://www.phoenixcontact.com/us/products/1627637>

Technical data

Product properties

Product type	Fixing frame
Product family	CHARX connect basic
Application	for attaching to infrastructure charging sockets
Type	Accessories
Affixed logo	Without logo
Charging standard	Type 2
Charging mode	Mode 3, Case B

Dimensions

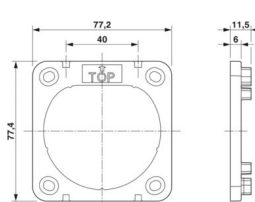
Width	77.2 mm
Height	77.4 mm
Depth	11.5 mm
Dimensional drawing	
Bore dimensions	60 mm x 60 mm

Material specifications

Color (Housing)	black (9005)
Material (Housing)	Plastic

Environmental and real-life conditions

Ambient conditions

Ambient temperature (operation)	-30 °C ... 50 °C
Ambient temperature (storage/transport)	-40 °C ... 80 °C

Standards and regulations

Standards

Standards/regulations	IEC 62196-2
-----------------------	-------------

Mounting

Mounting type Panel-mount frame	Front mounting (rear screw connection)
Mounting hole diameter	< 7.00 mm (Elongated hole, for spacing see hole pattern)
Screws included in the scope of delivery	M5x20 cylinder head screws

EV-T2SF-EM - Fixing frame



1627637

<https://www.phoenixcontact.com/us/products/1627637>

Classifications

ECLASS

ECLASS-11.0	27144792
ECLASS-12.0	27144792
ECLASS-13.0	27144792

ETIM

ETIM 9.0	EC002884
----------	----------

UNSPSC

UNSPSC 21.0	39121500
-------------	----------

EV-T2SF-EM - Fixing frame



1627637

<https://www.phoenixcontact.com/us/products/1627637>

Environmental product compliance

China RoHS	Environmentally friendly use period: unlimited = EFUP-e No hazardous substances above threshold values
------------	---

Phoenix Contact 2024 © - all rights reserved
<https://www.phoenixcontact.com>

Phoenix Contact USA
586 Fulling Mill Road
Middletown, PA 17057, United States
(+717) 944-1300
info@phoenixcon.com