

# HC-CIF-B10-HFWL-PL - DIN rail mounting frame



1424335

<https://www.phoenixcontact.com/us/products/1424335>

Please be informed that the data shown in this PDF document is generated from our online catalog. Please find the complete data in the user documentation. Our general terms of use for downloads are valid.

DIN rail mounting frame, design: B10, for contact inserts, Top frame



## Commercial data

Item number	1424335
Packing unit	1 pc
Minimum order quantity	1 pc
Sales key	BF60
Product key	BF7AHB
Catalog page	Page 684 (C-2-2019)
GTIN	4055626370736
Weight per piece (including packing)	43.24 g
Weight per piece (excluding packing)	43.24 g
Customs tariff number	85389099
Country of origin	CN

# HC-CIF-B10-HFWL-PL - DIN rail mounting frame



1424335

<https://www.phoenixcontact.com/us/products/1424335>

## Technical data

### Notes

General	for B10, BB18, DD42, HV3 contact inserts and B10 module frame
General	Protection against electric shock must be ensured by the user. The continuity of the PE connection must be verified and satisfied by the user. The PE connection must be implemented equilaterally.

### Product properties

Type	B10
Product type	DIN rail mounting frame
Housing type	DIN rail mounting frame
Protective cover	no
Series	HC-CIF-PL
Pg screw connection	none

### Dimensions

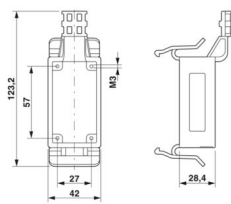
Dimensional drawing	
Width	42 mm
Height	61 mm
Length	125 mm

### Material specifications

Material	PC
Flammability rating according to UL 94	V0

### Mechanical properties

#### Mechanical data

Locking type	Clip
--------------	------

### Environmental and real-life conditions

#### Ambient conditions

Ambient temperature (operation)	-40 °C ... 125 °C
---------------------------------	-------------------

### Mounting

Assembly instructions	To ensure correct use, installation in an IP-protected space is required
-----------------------	--

# HC-CIF-B10-HFWL-PL - DIN rail mounting frame



1424335

<https://www.phoenixcontact.com/us/products/1424335>

## Classifications

### ECLASS

ECLASS-11.0	27440210
ECLASS-12.0	27440210
ECLASS-13.0	27440210

### ETIM

ETIM 9.0	EC002310
----------	----------

### UNSPSC

UNSPSC 21.0	39121400
-------------	----------

# HC-CIF-B10-HFWL-PL - DIN rail mounting frame



1424335

<https://www.phoenixcontact.com/us/products/1424335>

## Environmental product compliance

China RoHS	Environmentally friendly use period: unlimited = EFUP-e
	No hazardous substances above threshold values

Phoenix Contact 2024 © - all rights reserved  
<https://www.phoenixcontact.com>

Phoenix Contact USA  
586 Fulling Mill Road  
Middletown, PA 17057, United States  
(+717) 944-1300  
[info@phoenixcon.com](mailto:info@phoenixcon.com)