

# RSCWE 6-3/10 - Test terminal strip



3969926

<https://www.phoenixcontact.com/us/products/3969926>

Please be informed that the data shown in this PDF document is generated from our online catalog. Please find the complete data in the user documentation. Our general terms of use for downloads are valid.



Test terminal strip, nom. voltage: 400 V, nominal current: 24 A, number of connections: 20, number of positions: 10, connection method: Ring cable lug, 1 level, Rated cross section: 6 mm<sup>2</sup>, mounting type: Wall mounting, color: gray

## Your advantages

- Cost-effective, thanks to the tailored, modular design and use of standardized CLIPLINE complete accessories
- Space saving, thanks to compact, modular test terminal strips
- Maximum safety with leading and automatic transformer short circuit
- The integrated, robust switch contact is designed for the most stringent demands, and the use of high-quality materials ensures the transmission of signal currents, even after multiple actuations

## Commercial data

Item number	3969926
Packing unit	1 pc
Minimum order quantity	1 pc
Sales key	BE06
Product key	BE6113
Catalog page	Page 636 (C-1-2019)
GTIN	4055626127736
Weight per piece (including packing)	436.4 g
Weight per piece (excluding packing)	436.4 g
Customs tariff number	85369010
Country of origin	PL

## Technical data

### Product properties

Product type	Test terminal strip
Number of positions	10
Pitch	8.2 mm
Number of connections	20
Number of rows	1
Potentials	10

### Insulation characteristics

Overvoltage category	III
----------------------	-----

### Electrical properties

Rated surge voltage	4 kV
Maximum power dissipation for nominal condition	1.31 W
Test surge voltage	5 kV

### Connection data

Number of connections per level	20
Nominal cross section	6 mm <sup>2</sup>

#### 1 level

Screw thread	No 8 UNC
Tightening torque	1.5 ... 1.8 Nm
Internal cylindrical gage	A5
Connection in acc. with standard	IEC 60947-7-1
Conductor cross section flexible	0.5 mm <sup>2</sup> ... 10 mm <sup>2</sup>
Conductor cross section, flexible [AWG]	24 ... 8 (converted acc. to IEC)
2 conductors with same cross section, solid	0.5 mm <sup>2</sup> ... 6 mm <sup>2</sup>
2 conductors with same cross section, flexible	0.5 mm <sup>2</sup> ... 6 mm <sup>2</sup>
Nominal current	24 A
Maximum load current	30 A (with 10 mm <sup>2</sup> conductor cross section)
Nominal voltage	400 V AC/DC
Nominal cross section	6 mm <sup>2</sup>

#### Cable lug connection DIN 46234:1980-03

Connection in acc. with standard	DIN 46234:1980-03
Cross section	0.5 mm <sup>2</sup> ... 10 mm <sup>2</sup>
Cross section range AWG	(converted acc. to IEC)
Hole diameter	4.3 mm
Width	8 mm
Bolt diameter	4.1 mm
Connection in acc. with standard	DIN 46237:1970-07
Cross section	0.5 mm <sup>2</sup> ... 10 mm <sup>2</sup>

# RSCWE 6-3/10 - Test terminal strip

3969926

<https://www.phoenixcontact.com/us/products/3969926>

Cross section range AWG	(converted acc. to IEC)
Hole diameter	4.3 mm
Width	8 mm
Bolt diameter	4.1 mm
Identification color of ring cable lugs : red	1 mm <sup>2</sup>
Identification color of ring cable lugs : blue	2.5 mm <sup>2</sup>
Identification color of ring cable lugs : yellow	6 mm <sup>2</sup>

## Dimensions

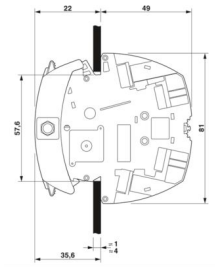
Dimensional drawing	
Width	114.1 mm
Height	81 mm
Depth	70.1 mm
Pitch	8.2 mm
Plate thickness	1 mm ... 4 mm

## Material specifications

Color	gray
Flammability rating according to UL 94	V0
Insulating material group	I
Insulating material	PA
Static insulating material application in cold	-60 °C
Temperature index of insulation material (DIN EN 60216-1 (VDE 0304-21))	125 °C
Relative insulation material temperature index (Elec., UL 746 B)	130 °C
Fire protection for rail vehicles (DIN EN 45545-2) R22	HL 1 - HL 3
Fire protection for rail vehicles (DIN EN 45545-2) R23	HL 1 - HL 3
Fire protection for rail vehicles (DIN EN 45545-2) R24	HL 1 - HL 3
Fire protection for rail vehicles (DIN EN 45545-2) R26	HL 1 - HL 3
Calorimetric heat release NFPA 130 (ASTM E 1354)	27,5 MJ/kg
Surface flammability NFPA 130 (ASTM E 162)	passed
Specific optical density of smoke NFPA 130 (ASTM E 662)	passed
Smoke gas toxicity NFPA 130 (SMP 800C)	passed

## Electrical tests

### Surge voltage test

Test voltage setpoint	4.8 kV
-----------------------	--------

# RSCWE 6-3/10 - Test terminal strip



3969926

<https://www.phoenixcontact.com/us/products/3969926>

Result	Test passed
--------	-------------

## Temperature-rise test

Requirement temperature-rise test	Increase in temperature $\leq 45$ K
Result	Test passed
Short-time withstand current 4 mm <sup>2</sup>	300 A
	500 A
	150 A
	1250 A
Result	Test passed

## Power-frequency withstand voltage

Test voltage setpoint	1.89 kV
Result	Test passed

## Mechanical properties

### General

Terminal block mounting	0.8 Nm ... 1 Nm
-------------------------	-----------------

### Mechanical data

Open side panel	No
-----------------	----

## Mechanical tests

### Mechanical strength

Result	Test passed
--------	-------------

### Attachment on the carrier

Test force setpoint	5 N
Result	Test passed

## Environmental and real-life conditions

### Needle-flame test

Time of exposure	30 s
Result	Test passed

### Oscillation/broadband noise

Specification	DIN EN 50155 (VDE 0115-200):2008-03
Spectrum	Service life test category 2, bogie-mounted
Frequency	$f_1 = 5$ Hz to $f_2 = 250$ Hz
ASD level	6.12 (m/s <sup>2</sup> )/Hz
Acceleration	3.12g
Test duration per axis	5 h
Test directions	X-, Y- and Z-axis
Result	Test passed

### Shocks

# RSCWE 6-3/10 - Test terminal strip



3969926

<https://www.phoenixcontact.com/us/products/3969926>

Specification	DIN EN 50155 (VDE 0115-200):2008-03
Pulse shape	Half-sine
Acceleration	30g
Shock duration	18 ms
Number of shocks per direction	3
Test directions	X-, Y- and Z-axis (pos. and neg.)
Result	Test passed

## Ambient conditions

Ambient temperature (storage/transport)	-25 °C ... 60 °C (for a short time, not exceeding 24 h, -60 °C to +70 °C)
Ambient temperature (assembly)	-5 °C ... 70 °C
Ambient temperature (actuation)	-5 °C ... 70 °C
Permissible humidity (storage/transport)	30 % ... 70 %

## Standards and regulations

Connection in acc. with standard	IEC 60947-7-1
----------------------------------	---------------

## Mounting

Mounting type	Wall mounting
Plate thickness	1 mm ... 4 mm
Terminal block mounting	0.8 Nm ... 1 Nm

# RSCWE 6-3/10 - Test terminal strip



3969926

<https://www.phoenixcontact.com/us/products/3969926>

## Classifications

### ECLASS

ECLASS-11.0	27141126
ECLASS-12.0	27141126
ECLASS-13.0	27250190

### ETIM

ETIM 9.0	EC002848
----------	----------

### UNSPSC

UNSPSC 21.0	39121400
-------------	----------

# RSCWE 6-3/10 - Test terminal strip



3969926

<https://www.phoenixcontact.com/us/products/3969926>

## Environmental product compliance

China RoHS	Environmentally friendly use period: unlimited = EFUP-e No hazardous substances above threshold values
------------	-----------------------------------------------------------------------------------------------------------

Phoenix Contact 2024 © - all rights reserved  
<https://www.phoenixcontact.com>

Phoenix Contact USA  
586 Fulling Mill Road  
Middletown, PA 17057, United States  
(+717) 944-1300  
[info@phoenixcon.com](mailto:info@phoenixcon.com)