

EV-T2AC-PARK - Charging connector holder



1624148

<https://www.phoenixcontact.com/us/products/1624148>

Please be informed that the data shown in this PDF document is generated from our online catalog. Please find the complete data in the user documentation. Our general terms of use for downloads are valid.



CHARX connect, Charging connector holder, Accessories, for vehicle charging connectors on charging stations (EVSE), Type 2, IEC 62196-2, Front mounting, housing: black, PHOENIX CONTACT logo

Product description

Retainer for Vehicle Connector as parking position at charging stations for E-Mobility (EVSE)

Your advantages

- Developed and produced in accordance with the IATF 16949 automotive standard and ISO 9001
- Individual branding, thanks to the use your own logo

Commercial data

Item number	1624148
Packing unit	1 pc
Minimum order quantity	1 pc
Sales key	EM01
Product key	XWBAJC
Catalog page	Page 45 (C-7-2019)
GTIN	4055626242828
Weight per piece (including packing)	137.4 g
Weight per piece (excluding packing)	132.7 g
Customs tariff number	39269097
Country of origin	DE

EV-T2AC-PARK - Charging connector holder



1624148

<https://www.phoenixcontact.com/us/products/1624148>

Technical data

Product properties

Product type	Charging connector holder
Product family	CHARX connect
Application	for vehicle charging connectors on charging stations (EVSE)
Type	Accessories
Affixed logo	PHOENIX CONTACT logo
Charging standard	Type 2
Charging mode	Mode 3

Dimensions

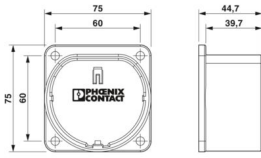
Width	75 mm
Height	75 mm
Depth	44.7 mm
Dimensional drawing	
Bore dimensions	60 mm x 60 mm

Material specifications

Color (Housing)	black (9005)
Material (Housing)	Plastic
Flammability rating according to UL 94	V0 ()

Mechanical properties

Securing	With locking clips for locking contour
Removal	Lifting and removal

Environmental and real-life conditions

Ambient conditions

Degree of protection	IP54 (plugged in)
Ambient temperature (operation)	-30 °C ... 50 °C
Ambient temperature (storage/transport)	-40 °C ... 80 °C

Standards and regulations

Standards

Standards/regulations	IEC 62196-2
-----------------------	-------------

Mounting

EV-T2AC-PARK - Charging connector holder



1624148

<https://www.phoenixcontact.com/us/products/1624148>

Mounting type Charging connector holder	Front mounting (0° ... 45° frontal inclination possible)
Mounting hole diameter	6.00 mm (ø)

EV-T2AC-PARK - Charging connector holder



1624148

<https://www.phoenixcontact.com/us/products/1624148>

Classifications

ECLASS

ECLASS-11.0	27144792
ECLASS-12.0	27144792
ECLASS-13.0	27144792

ETIM

ETIM 9.0	EC002884
----------	----------

UNSPSC

UNSPSC 21.0	39121500
-------------	----------

EV-T2AC-PARK - Charging connector holder



1624148

<https://www.phoenixcontact.com/us/products/1624148>

Environmental product compliance

China RoHS	Environmentally friendly use period: unlimited = EFUP-e No hazardous substances above threshold values
------------	---

Phoenix Contact 2024 © - all rights reserved
<https://www.phoenixcontact.com>

Phoenix Contact USA
586 Fulling Mill Road
Middletown, PA 17057, United States
(+717) 944-1300
info@phoenixcon.com