

# CUC-DST-GZNI-S/DSSC9 - D-SUB sleeve housings



1419722

<https://www.phoenixcontact.com/us/products/1419722>

Please be informed that the data shown in this PDF document is generated from our online catalog. Please find the complete data in the user documentation. Our general terms of use for downloads are valid.

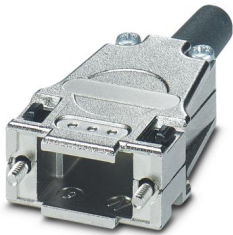

D-SUB sleeve housings, degree of protection: IP20, material: Zinc die-cast, cable outlet: straight, housing size: 1, color: Bare metallic

## Your advantages

- Easy to mount thanks to preassembled locking screws
- Angled conductor entry
- Antimagnetic plastic housing

## Commercial data

Item number	1419722
Packing unit	1 pc
Minimum order quantity	1 pc
Sales key	AB19
Product key	ABNCAE
GTIN	4055626188010
Weight per piece (including packing)	45.4 g
Weight per piece (excluding packing)	45 g
Customs tariff number	85389099
Country of origin	DE

# CUC-DST-GZNI-S/DSSC9 - D-SUB sleeve housings



1419722

<https://www.phoenixcontact.com/us/products/1419722>

## Technical data

### Product properties

Type	D-SUB
Product type	Sleeve housings
No. of cable outlets	1
Cable outlet	straight

### Connection data

Screw thread	4-40 UNC
--------------	----------

### Dimensions

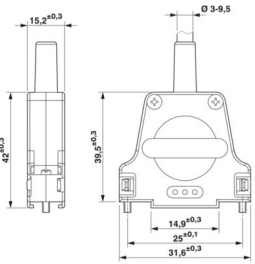
Dimensional drawing	
Width	31.6 mm
Height	15.2 mm
Depth	64.9 mm

### Material specifications

Color	Bare metallic
Flammability rating according to UL 94	V0
Housing surface material	nickel-plated
Housing material	Zinc die-cast

### Cable/line

External cable diameter ( )	3 mm ... 9.5 mm (Without bending protection)
-----------------------------	--

### Environmental and real-life conditions

#### Ambient conditions

Degree of protection	IP20
Ambient temperature (operation)	-35 °C ... 100 °C

### Mounting

Mounting type	Screw locking mechanism
---------------	-------------------------

# CUC-DST-GZNI-S/DSSC9 - D-SUB sleeve housings



1419722

<https://www.phoenixcontact.com/us/products/1419722>

## Classifications

### ECLASS

ECLASS-11.0	27440202
ECLASS-12.0	27440202
ECLASS-13.0	27440202

### ETIM

ETIM 9.0	EC000437
----------	----------

### UNSPSC

UNSPSC 21.0	31261500
-------------	----------

# CUC-DST-GZNI-S/DSSC9 - D-SUB sleeve housings



1419722

<https://www.phoenixcontact.com/us/products/1419722>

## Environmental product compliance

China RoHS	Environmentally friendly use period: unlimited = EFUP-e
	No hazardous substances above threshold values

Phoenix Contact 2024 © - all rights reserved  
<https://www.phoenixcontact.com>

Phoenix Contact USA  
586 Fulling Mill Road  
Middletown, PA 17057, United States  
(+717) 944-1300  
[info@phoenixcon.com](mailto:info@phoenixcon.com)