

MG-INC-M25-M67L-PTES-LG - Membrane screw connection



1415188

<https://www.phoenixcontact.com/us/products/1415188>

Please be informed that the data shown in this PDF document is generated from our online catalog. Please find the complete data in the user documentation. Our general terms of use for downloads are valid.



Membrane screw connection, material for screw connection: Polypropylene, external cable diameter 9 mm ... 17 mm, shielding: no, connecting thread: M25, color: light grey

Commercial data

Item number	1415188
Packing unit	20 pc
Minimum order quantity	20 pc
Sales key	BF68
Product key	BF7DFX
Catalog page	Page 693 (C-2-2019)
GTIN	4055626038025
Weight per piece (including packing)	6.1 g
Weight per piece (excluding packing)	5.722 g
Customs tariff number	39269097
Country of origin	DE

MG-INC-M25-M67L-PTES-LG - Membrane screw connection



1415188

<https://www.phoenixcontact.com/us/products/1415188>

Technical data

Mounting

Assembly instructions	for 0.8 mm ... 3.5 mm wall thickness, 25 mm ... 25.7 mm bore hole
-----------------------	---

Product properties

Product type	Full screw connection
Manufacturer	WISKA
Manufacturer Designation	CLIXX 25
Shielded	no

Dimensions

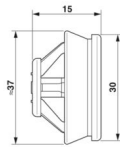
Dimensional drawing	
Length	15 mm
Length of the connecting thread	8 mm
Length without connecting thread	7 mm
Diameter	25 mm
Connecting thread diameter	25 mm
Hole diameter	25 mm ... 25.7 mm
Hexagon angular dimension	40 mm
Thread type connection side	M25

Material specifications

Color	light grey (RAL 7035)
Seal material	TPE
Material for screw connection	Polypropylene

Cable/line

External cable diameter ()	9 mm ... 17 mm
-----------------------------	----------------

Environmental and real-life conditions

Ambient conditions

Degree of protection	IP66
	IP67
Ambient temperature (operation)	-40 °C ... 65 °C

MG-INC-M25-M67L-PTES-LG - Membrane screw connection



1415188

<https://www.phoenixcontact.com/us/products/1415188>

Classifications

ECLASS

ECLASS-11.0	27144433
ECLASS-13.0	27140890

ETIM

ETIM 9.0	EC000441
----------	----------

UNSPSC

UNSPSC 21.0	39121300
-------------	----------

MG-INC-M25-M67L-PTES-LG - Membrane screw connection



1415188

<https://www.phoenixcontact.com/us/products/1415188>

Environmental product compliance

China RoHS	Environmentally friendly use period: unlimited = EFUP-e
	No hazardous substances above threshold values

Phoenix Contact 2024 © - all rights reserved
<https://www.phoenixcontact.com>

Phoenix Contact USA
586 Fulling Mill Road
Middletown, PA 17057, United States
(+717) 944-1300
info@phoenixcon.com