

Wall fixing bracket, for pressure switch

Part no. W-MCS
Article no. 050665
Catalog No. MCSX-W

Delivery program

Product range			Accessories
Basic function			Wall fixing bracket
			Article no. when ordered separately
For use with			MCS, MCSN

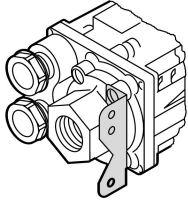

Notes

Wall mounting bracket can be rotated to right or left by 90°

Design verification as per IEC/EN 61439

Technical data for design verification			
Operating ambient temperature min.		°C	-25
Operating ambient temperature max.		°C	70

Technical data ETIM 6.0

Low-voltage industrial components (EG000017) / Accessories for low-voltage switch technology (EC002498)			
Electric engineering, automation, process control engineering / Low-voltage switch technology / Low-voltage switch technology (accessories) / Component for low-voltage switch technology (accessories) (ecl@ss8.1-27-37-92-01 [AKN570010])			
Type of accessory			-

Approvals

Product Standards			CSA-CC22.2 No. 14
CSA File No.			12528
CSA Class No.			3211-06
North America Certification			CSA certified

Dimensions

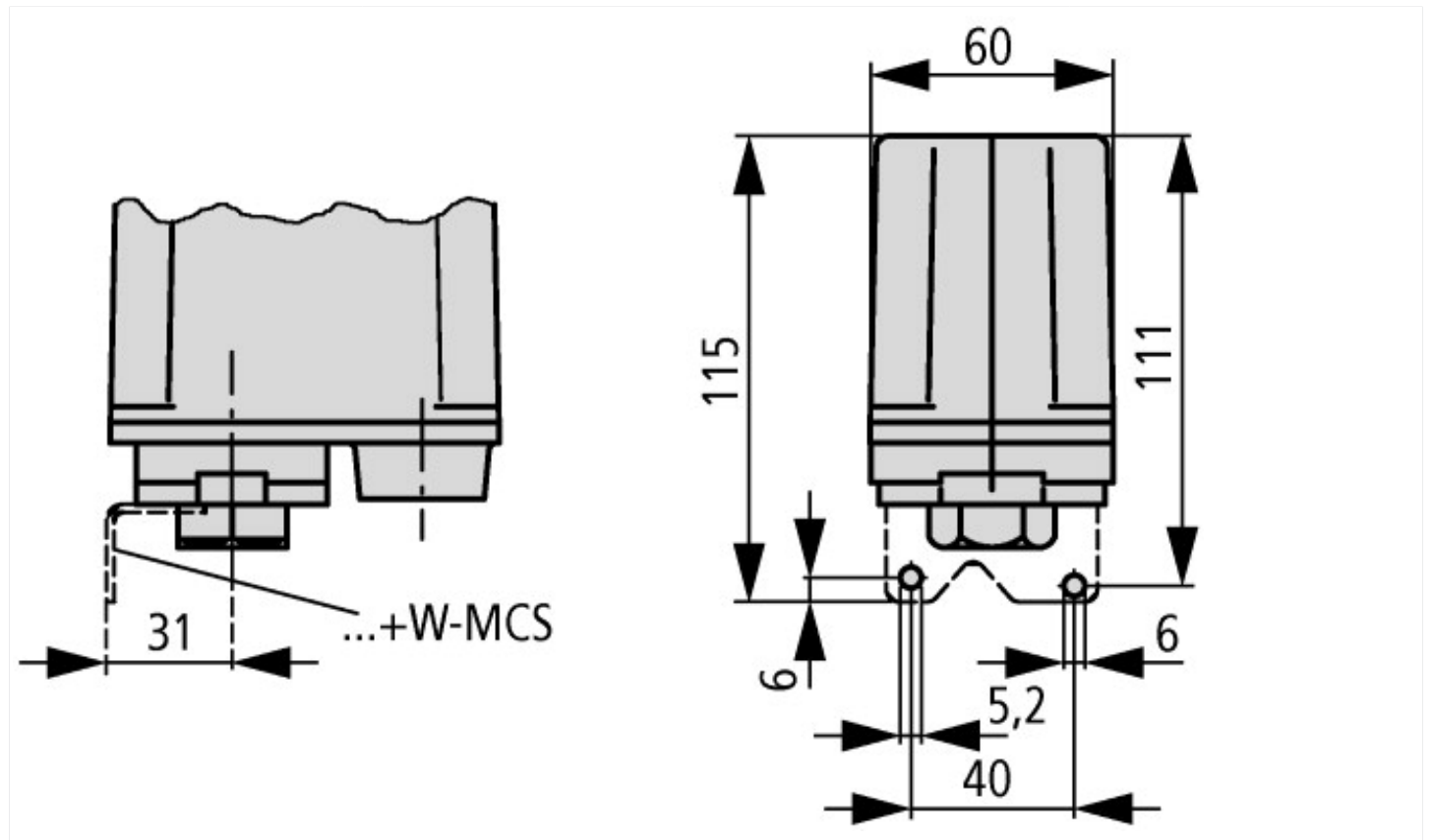

Additional product information (links)

IL05212001Z (AWA1320-0132) Pressure switch

IL05212001Z (AWA1320-0132) Pressure switch ftp://ftp.moeller.net/DOCUMENTATION/AWA_INSTRUCTIONS/IL05212001Z2016_02.pdf