



Its own control transformer, 1p, 500VA, prim.208-600V/ seco.2x115V

Part no. UT10,5-115
Article no. 206926
Catalog No. UT10P5-AI

Delivery program

| | | | |
|--|--|-----|---|
| Product range | | | Single-phase UT1 multi-winding transformers |
| Rated input voltage | | V | 208 – 600 |
| Rated output voltage | | V | 2 x 115 |
| Rated power | | kVA | 0.5 |
| Cu factor 1,30 | | | |
| Notes | | | |
| The transformers UT1 are suitable for use in control circuits to IEC/EN 60204 or VDE 0113. | | | |
| Transformer-protective circuit-breaker →#088907 | | | |

Technical data

General

| | | | |
|---------------------|--|--|--|
| Standards | | | |
| Built and tested to | | | (universal) control, isolating and safety transformers to VDE 0550 IEC/EN 61558-2-2/2-4/2-6 VDE 0570 Part 2-2/2-6 (safety transformer) VDE 0570 Part 2-4 (isolating transformer) |
| Suitable for use to | | | IEC/EN 60204-1, ÖVE-EN 13 VDE 0113, VDE 0100 Part 410 |
| Ambient temperature | | | -25 - 40 |

Characteristics

| | | | |
|--------------------------|--|------|---------|
| Terminations | | | ● |
| Insulation class | | | B |
| Rated frequency | | Hz | 50 - 60 |
| Primary tapping | | | ± 20 % |
| Degree of Protection | | | IP00 |
| Separate windings | | | ● |
| Fully vacuum-impregnated | | | ● |
| Reinforced insulation | | | ● |
| Rated duty factor | | % DF | 100 |

Electrical characteristics

| | | | |
|----------------------|--|----|---|
| Note | | | The following applies for the no-load loss, short-circuit loss (copper losses), short-circuit voltage and efficiency values: all details relate to a temperature of 20 °C |
| Total weight | | kg | 6.8 |
| No-load losses | | W | 26 |
| Short-circuit losses | | W | 23 |
| Shortcircuit voltage | | % | 3.5 |
| Efficiency | | | 0.918 |

Design verification as per IEC/EN 61439

| | | | |
|--|------------|----|-----|
| Technical data for design verification | | | |
| Rated operational current for specified heat dissipation | I_n | A | 0 |
| Heat dissipation per pole, current-dependent | P_{vid} | W | 0 |
| Equipment heat dissipation, current-dependent | P_{vid} | W | 0 |
| Static heat dissipation, non-current-dependent | P_{vs} | W | 49 |
| Heat dissipation capacity | P_{diss} | W | 0 |
| Operating ambient temperature min. | | °C | -25 |
| Operating ambient temperature max. | | °C | 40 |
| IEC/EN 61439 design verification | | | |
| 10.2 Strength of materials and parts | | | |

| | | |
|--|--|--|
| 10.2.2 Corrosion resistance | | Meets the product standard's requirements. |
| 10.2.3.1 Verification of thermal stability of enclosures | | Meets the product standard's requirements. |
| 10.2.3.2 Verification of resistance of insulating materials to normal heat | | Meets the product standard's requirements. |
| 10.2.3.3 Verification of resistance of insulating materials to abnormal heat and fire due to internal electric effects | | Meets the product standard's requirements. |
| 10.2.4 Resistance to ultra-violet (UV) radiation | | Meets the product standard's requirements. |
| 10.2.5 Lifting | | Does not apply, since the entire switchgear needs to be evaluated. |
| 10.2.6 Mechanical impact | | Does not apply, since the entire switchgear needs to be evaluated. |
| 10.2.7 Inscriptions | | Meets the product standard's requirements. |
| 10.3 Degree of protection of ASSEMBLIES | | Does not apply, since the entire switchgear needs to be evaluated. |
| 10.4 Clearances and creepage distances | | Meets the product standard's requirements. |
| 10.5 Protection against electric shock | | Does not apply, since the entire switchgear needs to be evaluated. |
| 10.6 Incorporation of switching devices and components | | Does not apply, since the entire switchgear needs to be evaluated. |
| 10.7 Internal electrical circuits and connections | | Is the panel builder's responsibility. |
| 10.8 Connections for external conductors | | Is the panel builder's responsibility. |
| 10.9 Insulation properties | | |
| 10.9.2 Power-frequency electric strength | | Is the panel builder's responsibility. |
| 10.9.3 Impulse withstand voltage | | Is the panel builder's responsibility. |
| 10.9.4 Testing of enclosures made of insulating material | | Is the panel builder's responsibility. |
| 10.10 Temperature rise | | The panel builder is responsible for the temperature rise calculation. Eaton will provide heat dissipation data for the devices. |
| 10.11 Short-circuit rating | | Is the panel builder's responsibility. The specifications for the switchgear must be observed. |
| 10.12 Electromagnetic compatibility | | Is the panel builder's responsibility. The specifications for the switchgear must be observed. |
| 10.13 Mechanical function | | The device meets the requirements, provided the information in the instruction leaflet (IL) is observed. |

Technical data ETIM 6.0

| | | |
|--|----|-----------|
| Low-voltage industrial components (EG000017) / One-phase control transformer (EC002486) | | |
| Electric engineering, automation, process control engineering / Transformer, converter, coil / Control transformer / One-phase control transformer (ecl@ss8.1-27-03-13-02 [AAB620012]) | | |
| Built as safety transformer | | Yes |
| Built as isolating transformer | | Yes |
| Built as energy saving transformer | | No |
| Primary voltage 1 | V | 208 - 600 |
| Primary voltage 2 | V | 0 - 0 |
| Primary voltage 3 | V | 0 - 0 |
| Primary voltage 4 | V | 0 - 0 |
| Primary voltage 5 | V | 0 - 0 |
| Primary voltage 6 | V | 0 - 0 |
| Primary voltage 7 | V | 0 - 0 |
| Primary voltage 8 | V | 0 - 0 |
| Primary voltage 9 | V | 0 - 0 |
| Primary voltage 10 | V | 0 - 0 |
| Secondary voltage 1 | V | 115 - 115 |
| Secondary voltage 2 | V | 115 - 115 |
| Secondary voltage 3 | V | 0 - 0 |
| Secondary voltage 4 | V | 0 - 0 |
| Secondary voltage 5 | V | 0 - 0 |
| Secondary voltage 6 | V | 0 - 0 |
| Secondary voltage 7 | V | 0 - 0 |
| Secondary voltage 8 | V | 0 - 0 |
| Secondary voltage 9 | V | 0 - 0 |
| Secondary voltage 10 | V | 0 - 0 |
| Rated apparent power | VA | 500 |
| Type of insulation material acc. IEC 85 | | B |
| Short-circuit-proof | | No |

| | | |
|--------------------------------|----|------|
| Relative short circuit voltage | % | 3.5 |
| Width | mm | 121 |
| Height | mm | 133 |
| Depth | mm | 120 |
| Degree of protection (IP) | | IP00 |
| Ring core | | No |
| Suitable for mounting on PCB | | No |
| Modular version | | No |

Approvals

| | | |
|--------------------------------------|--|---|
| Product Standards | | UL 506; UL5085-1; UL 5085-2; CSA-C22.2 No. 66; CSA-C22.2 No. 66.1-06; CSA-C22.2 No. 66.2-06; IEC/EN 61558-2-2; CE marking |
| UL File No. | | E167225 |
| UL Category Control No. | | XPTQ2, XPTQ8 |
| CSA File No. | | UL report applies to both US and Canada |
| CSA Class No. | | - |
| North America Certification | | UL recognized, certified by UL for use in Canada |
| Specially designed for North America | | No |
| Suitable for | | Branch circuits |
| Max. Voltage Rating | | 600 V AC |
| Degree of Protection | | IEC: IP00, UL/CSA Type: - |

Dimensions

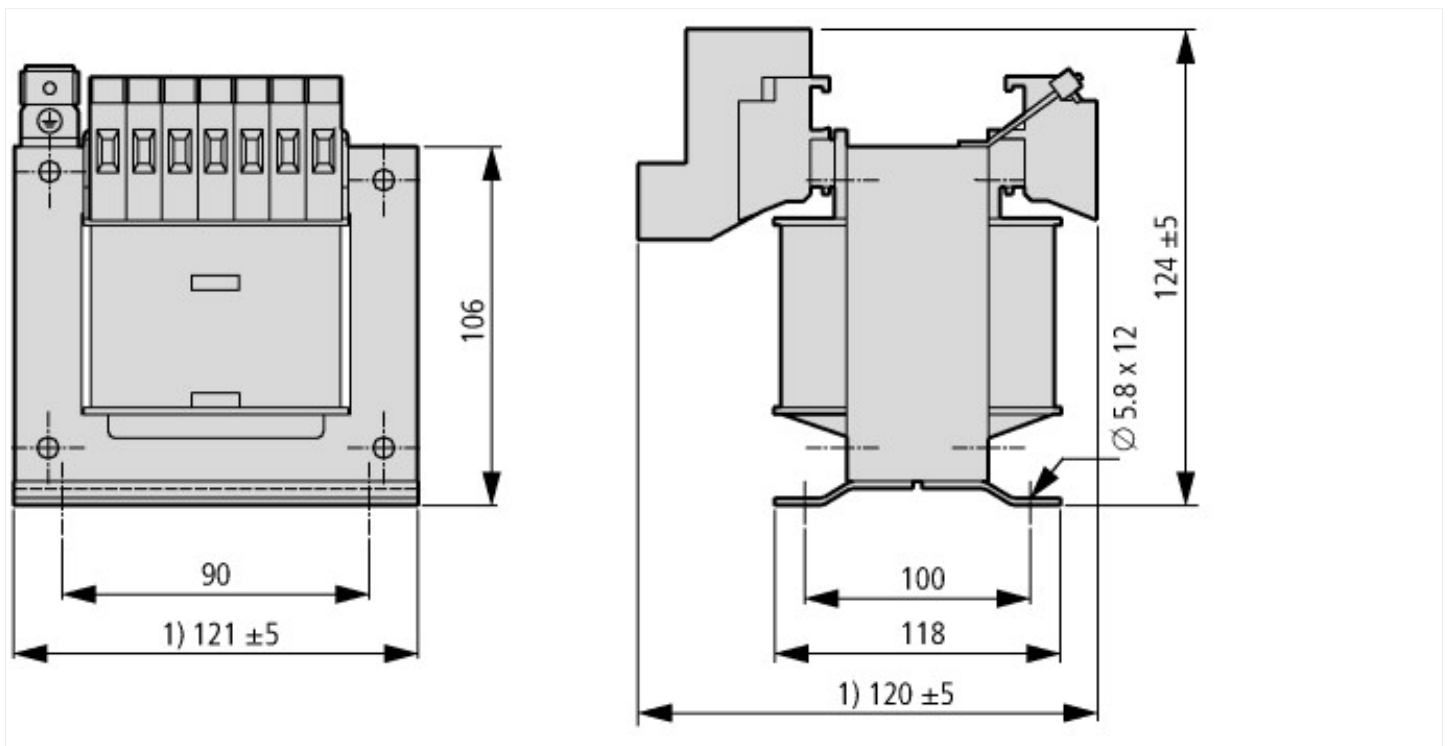

U_s = Secondary voltage

- ① Maximum space requirement
- ② With UT10,1 Earth connection at bottom