



Changeoverswitches, Contacts: 10, 100 A, front plate: 1-0-2, 60 °, maintained, flush mounting

Part no. T5-5-8361/E
Article no. 095280



Similar to illustration

Delivery program

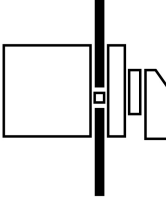
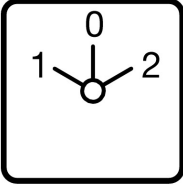
Product range			Control switches																																																																																				
Part group reference			T5																																																																																				
Basic function			Changeoverswitches with black thumb grip and front plate																																																																																				
Contacts			10																																																																																				
Degree of Protection			Front IP65																																																																																				
Design			flush mounting																																																																																				
																																																																																							
Contact sequence			<table border="1"> <tr> <td></td> <td>1</td> <td>0</td> <td>2</td> </tr> <tr> <td>1</td> <td>o</td> <td>X</td> <td></td> </tr> <tr> <td>2</td> <td>o</td> <td></td> <td>X</td> </tr> <tr> <td>3</td> <td>o</td> <td></td> <td></td> </tr> <tr> <td>4</td> <td>o</td> <td></td> <td>X</td> </tr> <tr> <td>5</td> <td>o</td> <td>X</td> <td></td> </tr> <tr> <td>6</td> <td>o</td> <td></td> <td></td> </tr> <tr> <td>7</td> <td>o</td> <td></td> <td>X</td> </tr> <tr> <td>8</td> <td>o</td> <td></td> <td></td> </tr> <tr> <td>9</td> <td>o</td> <td>X</td> <td></td> </tr> <tr> <td>10</td> <td>o</td> <td></td> <td>X</td> </tr> <tr> <td>11</td> <td>o</td> <td></td> <td></td> </tr> <tr> <td>12</td> <td>o</td> <td></td> <td>X</td> </tr> <tr> <td>13</td> <td>o</td> <td>X</td> <td></td> </tr> <tr> <td>14</td> <td>o</td> <td></td> <td></td> </tr> <tr> <td>15</td> <td>o</td> <td></td> <td>X</td> </tr> <tr> <td>16</td> <td>o</td> <td></td> <td></td> </tr> <tr> <td>17</td> <td>o</td> <td>X</td> <td></td> </tr> <tr> <td>18</td> <td>o</td> <td></td> <td>X</td> </tr> <tr> <td>19</td> <td>o</td> <td></td> <td></td> </tr> <tr> <td>20</td> <td>o</td> <td></td> <td>X</td> </tr> </table>		1	0	2	1	o	X		2	o		X	3	o			4	o		X	5	o	X		6	o			7	o		X	8	o			9	o	X		10	o		X	11	o			12	o		X	13	o	X		14	o			15	o		X	16	o			17	o	X		18	o		X	19	o			20	o		X
	1	0	2																																																																																				
1	o	X																																																																																					
2	o		X																																																																																				
3	o																																																																																						
4	o		X																																																																																				
5	o	X																																																																																					
6	o																																																																																						
7	o		X																																																																																				
8	o																																																																																						
9	o	X																																																																																					
10	o		X																																																																																				
11	o																																																																																						
12	o		X																																																																																				
13	o	X																																																																																					
14	o																																																																																						
15	o		X																																																																																				
16	o																																																																																						
17	o	X																																																																																					
18	o		X																																																																																				
19	o																																																																																						
20	o		X																																																																																				
Switching angle		°	60																																																																																				
Switching performance			maintained With 0 (Off) position																																																																																				
Front plate no.			 FS 684																																																																																				
front plate			1-0-2																																																																																				
Motor rating AC-23A, 50 - 60 Hz																																																																																							
400 V	P	kW	55																																																																																				
Rated uninterrupted current	I _u	A	100																																																																																				
Number of contact units		contact unit(s)	5																																																																																				

Technical data

General

Standards			IEC/EN 60947, VDE 0660, IEC/EN 60204 Switch-disconnector according to IEC/EN 60947-3
Climatic proofing			Damp heat, constant, to IEC 60068-2-78 Damp heat, cyclic, to IEC 60068-2-30
Ambient temperature			
Open		°C	-25 - +50
Enclosed		°C	-25 - +40
Overvoltage category/pollution degree			III/3
Rated impulse withstand voltage	U_{imp}	V AC	6000
Mechanical shock resistance		g	15
Mounting position			As required
Protection against direct contact when actuated from front (EN 50274)			Finger and back-of-hand proof

Contacts

Electrical characteristics			
Rated operational voltage	U_e	V AC	690
Rated uninterrupted current	I_u	A	100
Note on rated uninterrupted current I_u			Rated uninterrupted current I_u is specified for max. cross-section.
Load rating with intermittent operation, class 12			
AB 25 % DF		$\times I_e$	2
AB 40 % DF		$\times I_e$	1.6
AB 60 % DF		$\times I_e$	1.3
Short-circuit rating			
Fuse		A gG/gL	100
Rated short-time withstand current (1 s current)	I_{cw}	A_{rms}	1700
Note on rated short-time withstand current I_{cw}			Current for a time of 1 second
Rated conditional short-circuit current	I_q	kA	2

Switching capacity

cos φ rated making capacity as per IEC 60947-3		A	950
Rated breaking capacity cos φ to IEC 60947-3		A	
230 V		A	760
400/415 V		A	740
500 V		A	590
690 V		A	420
Safe isolation to EN 61140			
between the contacts		V AC	440
Current heat loss per contact at I_e		W	7.5
Current heat loss per auxiliary circuit at I_e (AC-15/230 V)		CO	7.5
Lifespan, mechanical	Operations	$\times 10^6$	> 0.5
Maximum operating frequency	Operations/h		1200
AC			
AC-3			
Rating, motor load switch	P	kW	
220 V 230 V	P	kW	22
230 V Star-delta	P	kW	30
400 V 415 V	P	kW	30
400 V Star-delta	P	kW	45
500 V	P	kW	30
500 V Star-delta	P	kW	45
690 V	P	kW	15
690 V Star-delta	P	kW	22
Rated operational current motor load switch			
230 V	I_e	A	71
230 V star-delta	I_e	A	100
400V 415 V	I_e	A	55

400 V star-delta	I _e	A	95.3
500 V	I _e	A	44
500 V star-delta	I _e	A	76.2
690 V	I _e	A	17
690 V star-delta	I _e	A	29.4
AC-21A			
Rated operational current switch			
440 V	I _e	A	100
AC-23A			
Motor rating AC-23A, 50 - 60 Hz			
230 V	P	kW	30
400 V 415 V	P	kW	55
500 V	P	kW	37
690 V	P	kW	30
Rated operational current motor load switch			
230 V	I _e	A	100
400 V 415 V	I _e	A	100
500 V	I _e	A	55
690 V	I _e	A	32
DC			
DC-1, Load-break switches L/R = 1 ms			
Rated operational current			
	I _e	A	80
Voltage per contact pair in series			
		V	60
Control circuit reliability at 24 V DC, 10 mA			
	Fault probability	H _F	< 10 ⁻⁵ , < 1 fault in 100000 operations

Terminal capacities

Solid or stranded		mm ²	1 x (2,5 - 35) 2 x (2,5 - 16)
Flexible with ferrules to DIN 46228		mm ²	1 x (1 - 25) 2 x (1.5 - 10)
Terminal screw			M6
Max. tightening torque		Nm	4

Technical safety parameters:

Notes			B10 _d values as per EN ISO 13849-1, table C1
--------------	--	--	---

Rating data for approved types

Terminal capacity			
Terminal screw			M6

Design verification as per IEC/EN 61439

Technical data for design verification			
Rated operational current for specified heat dissipation	I _n	A	100
Heat dissipation per pole, current-dependent	P _{vid}	W	7.5
Equipment heat dissipation, current-dependent	P _{vid}	W	0
Static heat dissipation, non-current-dependent	P _{vs}	W	0
Heat dissipation capacity	P _{diss}	W	0
Operating ambient temperature min.		°C	-25
Operating ambient temperature max.		°C	50
IEC/EN 61439 design verification			
10.2 Strength of materials and parts			
10.2.2 Corrosion resistance			
			Meets the product standard's requirements.
10.2.3.1 Verification of thermal stability of enclosures			
			Meets the product standard's requirements.
10.2.3.2 Verification of resistance of insulating materials to normal heat			
			Meets the product standard's requirements.
10.2.3.3 Verification of resistance of insulating materials to abnormal heat and fire due to internal electric effects			
			Meets the product standard's requirements.
10.2.4 Resistance to ultra-violet (UV) radiation			
			Please enquire
10.2.5 Lifting			
			Does not apply, since the entire switchgear needs to be evaluated.

10.2.6 Mechanical impact		Does not apply, since the entire switchgear needs to be evaluated.
10.2.7 Inscriptions		Meets the product standard's requirements.
10.3 Degree of protection of ASSEMBLIES		Does not apply, since the entire switchgear needs to be evaluated.
10.4 Clearances and creepage distances		Meets the product standard's requirements.
10.5 Protection against electric shock		Does not apply, since the entire switchgear needs to be evaluated.
10.6 Incorporation of switching devices and components		Does not apply, since the entire switchgear needs to be evaluated.
10.7 Internal electrical circuits and connections		Is the panel builder's responsibility.
10.8 Connections for external conductors		Is the panel builder's responsibility.
10.9 Insulation properties		
10.9.2 Power-frequency electric strength		Is the panel builder's responsibility.
10.9.3 Impulse withstand voltage		Is the panel builder's responsibility.
10.9.4 Testing of enclosures made of insulating material		Is the panel builder's responsibility.
10.10 Temperature rise		The panel builder is responsible for the temperature rise calculation. Eaton will provide heat dissipation data for the devices.
10.11 Short-circuit rating		Is the panel builder's responsibility. The specifications for the switchgear must be observed.
10.12 Electromagnetic compatibility		Is the panel builder's responsibility. The specifications for the switchgear must be observed.
10.13 Mechanical function		The device meets the requirements, provided the information in the instruction leaflet (IL) is observed.

Technical data ETIM 6.0

Low-voltage industrial components (EG000017) / Off-load switch (EC001105)		
Electric engineering, automation, process control engineering / Low-voltage switch technology / Off-load switch, circuit breaker, control switch / Changeover switch (ecl@ss8.1-27-37-14-05 [AKF062010])		
Model		Reverser
Number of poles		5
With 0 (off) position		Yes
With retraction in 0-position		No
Rated permanent current I _u	A	100
Rated operation current I _e at AC-3, 400 V	A	55
Rated operation power at AC-3, 400 V	kW	30
Degree of protection (IP), front side		IP65
Number of auxiliary contacts as normally closed contact		0
Number of auxiliary contacts as normally open contact		0
Number of auxiliary contacts as change-over contact		0
Suitable for ground mounting		No
Suitable for front mounting 4-hole		Yes
Suitable for distribution board installation		No
Suitable for intermediate mounting		No
Complete device in housing		No
Type of control element		Toggle
Type of electrical connection of main circuit		Screw connection

Dimensions

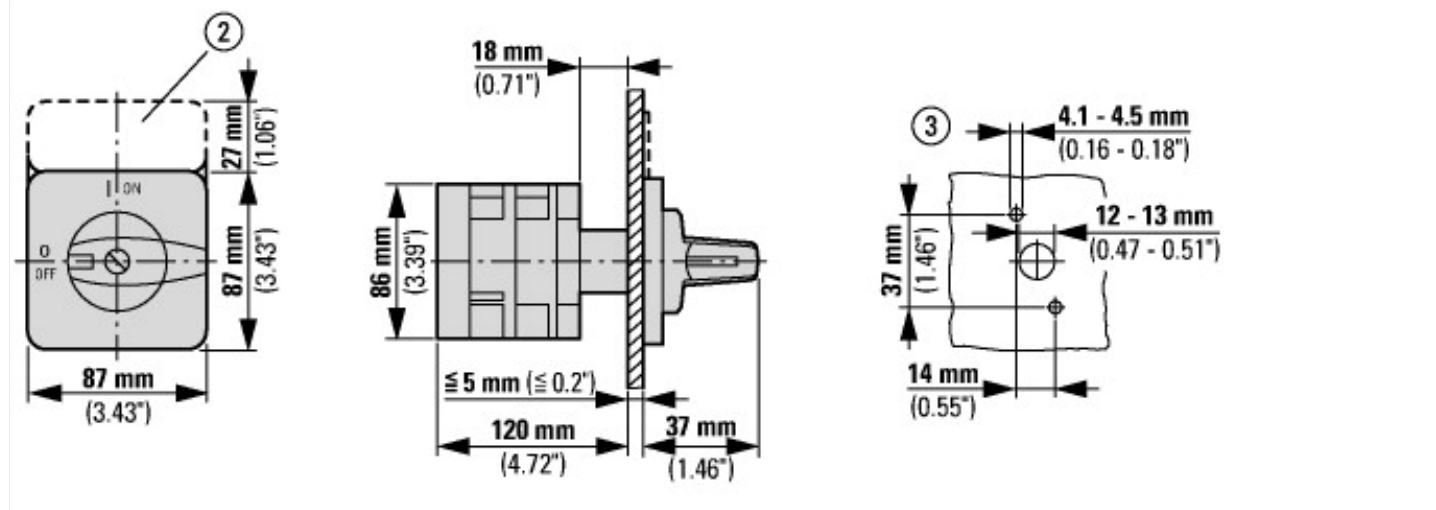

② ZFS... Label mount not included as standard

③ Drilling dimensions door

Cam switches T5B and T5 are of identical design, only their contacts are different

Additional product information (links)

IL03801009Z (AWA1150-1692) Cam switches: switch-disconnectors

IL03801009Z (AWA1150-1692) Cam switches: switch-disconnectors	ftp://ftp.moeller.net/DOCUMENTATION/AWA_INSTRUCTIONS/IL03801009Z2016_07.pdf
Display flip catalog page.	http://ecat.moeller.net/flip-cat/?edition=K115A&startpage=135
Technical overview cam switch, switch-disconnector	http://de.ecat.moeller.net/flip-cat/?edition=HPLTEv1&startpage=4.2
System overview cam switch T	http://de.ecat.moeller.net/flip-cat/?edition=HPLTEv1&startpage=4.4
System overview switch-disconnector P	http://de.ecat.moeller.net/flip-cat/?edition=HPLTEv1&startpage=4.6
Key to part numbers Cam switch	http://de.ecat.moeller.net/flip-cat/?edition=HPLTEv1&startpage=4.8
Key to part numbers Switch-disconnector	http://de.ecat.moeller.net/flip-cat/?edition=HPLTEv1&startpage=4.8
Switches for ATEX	http://www.coopercrouse-hinds.eu/en/products/25-ex-safety-and-main-current-switches.html