



Control transformer, 8, 3kVA, 1p, non-standard voltage

Part no. STZ8,3(*/*)
Article no. 201062
Catalog No. -

Delivery program

Product range		Single-phase control transformers ST...
Basic function		Single-phase control, isolating and safety transformers STI, STZ
Rated input voltage	V	50 – 950 ± 5 %
Rated output voltage	V	12 – 1000
Rated power	kVA	8.3
Short-time rating	kVA	21
Cu factor 14,00		

Notes

- Transformers with the rated output voltages $\frac{\equiv}{\equiv}$ 50 V can be used as safety transformers to IEC/EN 61558.

When ordering, the part no. must include the following details:

STZ0.06(*/*)

1. Wildcard $\frac{\equiv}{\equiv}$ Nominal input voltage

2nd Wildcard $\frac{\equiv}{\equiv}$ Nominal output voltage

Ordering example

- desired part no. STZ0.06
- Desired rated input voltage 230 V
- Desired rated output voltage 12 V

The correct part no. is

STZ0.06(230/12)

Additional tapings → 931897

Notes

- Transformers with the rated output voltages $\frac{\equiv}{\equiv}$ 50 V can be used as safety transformers to IEC/EN 61558.

Technical data

General

Standards		
Built and tested to		IEC/EN 61558-2-2/2-4/2-6 VDE 0570 Part 2-2 VDE 0570 Part 2-6 (safety transformers) VDE 0570 Part 2-4 (isolating transformer)
Suitable for use to		IEC/EN 60204-1, ÖVE-EN 13 VDE 0113, VDE 0100 Part 410
Ambient temperature		-25 - 40

Characteristics

Terminations		● (< 63 A)
Connection lugs		● (< 63 A)
Insulation class		B
Rated frequency	Hz	50 - 60
Primary tapping		± 5 %
Degree of Protection		IP00
Separate windings		●
Fully vacuum-impregnated		●
Reinforced insulation		●
Rated duty factor	% DF	100

Electrical characteristics

Note		The following applies for the no-load loss, short-circuit loss (copper losses), short-circuit voltage and efficiency values: all details relate to a temperature of 20 °C
------	--	---

Total weight	kg	55
No-load losses	W	65
Short-circuit losses	W	200
Shortcircuit voltage	%	4
Efficiency		0.97

Design verification as per IEC/EN 61439

Technical data for design verification			
Rated operational current for specified heat dissipation	I_n	A	0
Heat dissipation per pole, current-dependent	P_{vid}	W	0
Equipment heat dissipation, current-dependent	P_{vid}	W	0
Static heat dissipation, non-current-dependent	P_{vs}	W	265
Heat dissipation capacity	P_{diss}	W	0
Operating ambient temperature min.		°C	-25
Operating ambient temperature max.		°C	40
IEC/EN 61439 design verification			
10.2 Strength of materials and parts			
10.2.2 Corrosion resistance			
			Meets the product standard's requirements.
10.2.3.1 Verification of thermal stability of enclosures			
			Meets the product standard's requirements.
10.2.3.2 Verification of resistance of insulating materials to normal heat			
			Meets the product standard's requirements.
10.2.3.3 Verification of resistance of insulating materials to abnormal heat and fire due to internal electric effects			
			Meets the product standard's requirements.
10.2.4 Resistance to ultra-violet (UV) radiation			
			Meets the product standard's requirements.
10.2.5 Lifting			
			Does not apply, since the entire switchgear needs to be evaluated.
10.2.6 Mechanical impact			
			Does not apply, since the entire switchgear needs to be evaluated.
10.2.7 Inscriptions			
			Meets the product standard's requirements.
10.3 Degree of protection of ASSEMBLIES			
			Does not apply, since the entire switchgear needs to be evaluated.
10.4 Clearances and creepage distances			
			Meets the product standard's requirements.
10.5 Protection against electric shock			
			Does not apply, since the entire switchgear needs to be evaluated.
10.6 Incorporation of switching devices and components			
			Does not apply, since the entire switchgear needs to be evaluated.
10.7 Internal electrical circuits and connections			
			Is the panel builder's responsibility.
10.8 Connections for external conductors			
			Is the panel builder's responsibility.
10.9 Insulation properties			
10.9.2 Power-frequency electric strength			
			Is the panel builder's responsibility.
10.9.3 Impulse withstand voltage			
			Is the panel builder's responsibility.
10.9.4 Testing of enclosures made of insulating material			
			Is the panel builder's responsibility.
10.10 Temperature rise			
			The panel builder is responsible for the temperature rise calculation. Eaton will provide heat dissipation data for the devices.
10.11 Short-circuit rating			
			Is the panel builder's responsibility. The specifications for the switchgear must be observed.
10.12 Electromagnetic compatibility			
			Is the panel builder's responsibility. The specifications for the switchgear must be observed.
10.13 Mechanical function			
			The device meets the requirements, provided the information in the instruction leaflet (IL) is observed.

Technical data ETIM 6.0

Low-voltage industrial components (EG000017) / One-phase control transformer (EC002486)			
Electric engineering, automation, process control engineering / Transformer, converter, coil / Control transformer / One-phase control transformer (ecl@ss8.1-27-03-13-02 [AAB620012])			
Built as safety transformer			Yes
Built as isolating transformer			Yes
Built as energy saving transformer			No
Primary voltage 1	V		50 - 950
Primary voltage 2	V		50 - 950
Primary voltage 3	V		50 - 950
Primary voltage 4	V		50 - 950
Primary voltage 5	V		50 - 950
Primary voltage 6	V		50 - 950

Primary voltage 7	V	0 - 0
Primary voltage 8	V	0 - 0
Primary voltage 9	V	0 - 0
Primary voltage 10	V	0 - 0
Secondary voltage 1	V	12 - 1000
Secondary voltage 2	V	12 - 1000
Secondary voltage 3	V	12 - 1000
Secondary voltage 4	V	12 - 1000
Secondary voltage 5	V	12 - 1000
Secondary voltage 6	V	12 - 1000
Secondary voltage 7	V	0 - 0
Secondary voltage 8	V	0 - 0
Secondary voltage 9	V	0 - 0
Secondary voltage 10	V	0 - 0
Rated apparent power	VA	8300
Type of insulation material acc. IEC 85		B
Short-circuit-proof		No
Relative short circuit voltage	%	4
Width	mm	260
Height	mm	295
Depth	mm	244
Degree of protection (IP)		IP00
Ring core		No
Suitable for mounting on PCB		No
Modular version		No

Approvals

Product Standards		IEC/EN 61558-2-2; CE marking
UL File No.		-
UL Category Control No.		XPTQ2, XPTQ8
CSA File No.		-
CSA Class No.		-
North America Certification		-
Specially designed for North America		No
Suitable for		Branch circuits
Max. Voltage Rating		600 V AC
Degree of Protection		IEC: IP00, UL/CSA Type: -

Dimensions

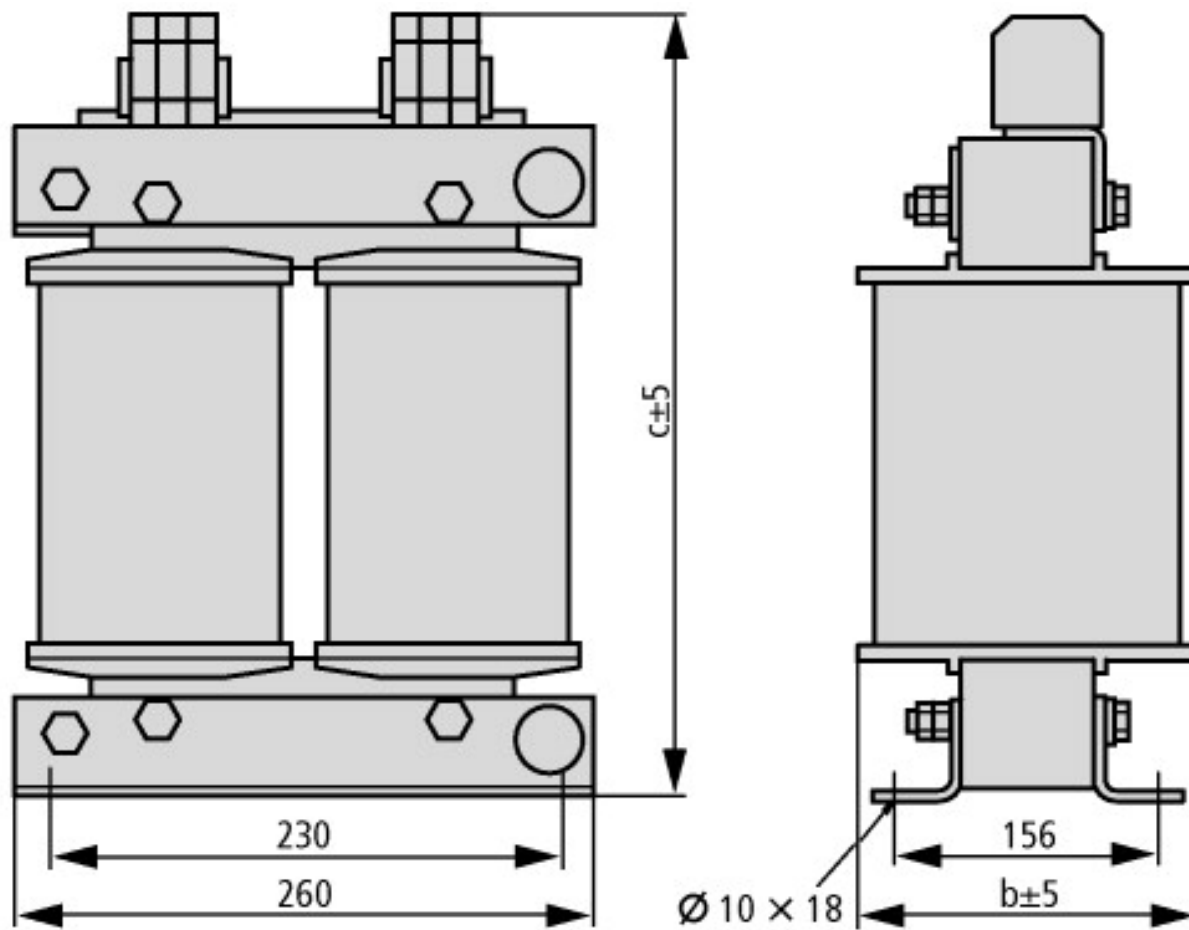

	b	c
12 V	–	–
24 V	230	374
42 V	230	374
110 V	244	374
230 V	244	374

- ① Connection lugs
- ② with STI/STZ0,06 ... 0,16 earth connection at bottom
- ③ The higher rated voltage is valid