



## Circuit-breaker, 4p, 100A

Part no. **NZMH2-4-VE100**  
 Article no. **265941**

Similar to illustration

## Delivery program

|                     |  |  |  |
|---------------------|--|--|--|
| Product range       |  |  | Circuit-breaker  |
| Protective function |  |  | Systems, cable, selectivity and generator protection   |
| Standard/Approval   |  |  | IEC  |
| Installation type   |  |  | Fixed  |
| Release system      |  |  | Electronic release   |
| Construction size   |  |  | NZM2   |
| Description         |  |  | R.m.s. value measurement and "thermal memory"<br>adjustable time delay setting to overcome current peaks tr: 2 – 20 s at 6 x I <sub>r</sub> also infinity (without overload releases)<br>Adjustable delay time tsd: Steps: 0, 20, 60, 100, 200, 300, 500, 750, 1000 ms<br>i <sup>2</sup> t constant function: fixed OFF<br>Set value in neutral conductor is synchronous with set value I <sub>r</sub> of main pole. |
| Number of poles     |  |  | 4 pole   |
| Standard equipment  |  |  | Screw connection   |





## Switching capacity

|                 |                 |    |     |
|-----------------|-----------------|----|-----|
| 400/415 V 50 Hz | I <sub>cu</sub> | kA | 150 |
|-----------------|-----------------|----|-----|

## Rated current = rated uninterrupted current

|   |                                 |     |     |
|---|---------------------------------|-----|-----|
| Rated current = rated uninterrupted current | I <sub>n</sub> = I <sub>u</sub> | A   | 100 |
| Neutral conductor                           | % of phase conductor            | CSA | 100 |

## Setting range

|  |  |   |              |
|--|--|---|--------------|
| Overload trip  |  |   |              |
|               | I <sub>r</sub>                         | A | 50 - 100     |
| Main pole<br> | I <sub>r</sub>                         | A | 50 - 100     |
| Short-circuit releases   |  |   |              |
|               |  |   |              |
| Non-delayed  | I <sub>i</sub> = I <sub>n</sub> x ...  |   | 1200 A fixed |
|               |  |   |              |
| Delayed  | I <sub>sd</sub> = I <sub>r</sub> x ... |   | 2 - 10       |
|               |  |   |              |

## Technical data

### General

|   |  |    |  |
|---|--|----|--|
| Standards   |  |    | IEC/EN 60947   |
| Protection against direct contact   |  |    | Finger and back of hand proof to VDE 0106 Part 100                             |
| Climatic proofing   |  |    | Damp heat, constant, to IEC 60068-2-78<br>Damp heat, cyclic, to IEC 60068-2-30 |
| Ambient temperature   |  |    |  |
| Ambient temperature, storage  |  | °C | - 40 - + 70  |
| Operation   |  | °C | -25 - +70  |
| Mechanical shock resistance (10 ms half-sinusoidal shock) according to IEC 60068-2-27 |  | g  | 20 (half-sinusoidal shock 20 ms)   |

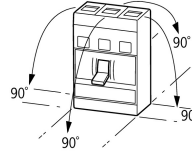
|  |      |  |  |
|--|------|--|--|
| Safe isolation to EN 61140                   |      |  |  |
| Between auxiliary contacts and main contacts | V AC |  | 500  |
| between the auxiliary contacts               | V AC |  | 300  |
| Weight                                       | kg   |  | 3.5  |
| Mounting position                            |      |  | Vertical and 90° in all directions<br> <ul style="list-style-type: none"> <li>With residual-current release XFI:               <ul style="list-style-type: none"> <li>- NZM1, N1, NZM2, N2: vertical and 90° in all directions</li> <li>with plug-in adapter elements                   <ul style="list-style-type: none"> <li>- NZM1, N1, NZM2, N2: vertical, 90° right/left</li> </ul> </li> <li>with withdrawable unit:                   <ul style="list-style-type: none"> <li>- NZM3, N3: vertical, 90 ° left</li> <li>- NZM4, N4: vertical</li> </ul> </li> <li>with remote operator:                   <ul style="list-style-type: none"> <li>- NZM2, N(S)2, NZM3, N(S)3, NZM4, N(S)4: vertical and 90° in all directions</li> </ul> </li> </ul> </li> </ul> |
| Direction of incoming supply                 |      |  | as required  |
| Degree of protection                         |      |  |  |
| Device                                       |      |  | In the operating controls area: IP20 (basic degree of protection)  |
| Enclosures                                   |      |  | With insulating surround: IP40<br>With door coupling rotary handle: IP66   |
| Terminations                                 |      |  | Tunnel terminal: IP10<br>Phase isolator and strip terminal: IP00   |
| Other technical data (sheet catalogue)       |      |  | Weight<br>Temperature dependency, Derating<br>Effective power loss   |

### Circuit-breakers

|   |             |      |   |
|---|-------------|------|---|
| Rated current = rated uninterrupted current | $I_n = I_u$ | A    | 100   |
| Rated surge voltage invariability           | $U_{imp}$   |      |   |
| Main contacts                               |             | V    | 8000  |
| Auxiliary contacts                          |             | V    | 6000  |
| Rated operational voltage                   | $U_e$       | V AC | 690   |
| Overvoltage category/pollution degree       |             |      | III/3   |
| Rated insulation voltage                    | $U_i$       | V    | 1000  |
| Use in unearthed supply systems             |             | V    |  690 |

### Switching capacity

|   |          |    |   |
|---|----------|----|---|
| Rated short-circuit making capacity             | $I_{cm}$ |    |   |
| 240 V   | $I_{cm}$ | kA | 330   |
| 400/415 V                                       | $I_{cm}$ | kA | 330   |
| 440 V 50/60 Hz                                  | $I_{cm}$ | kA | 286   |
| 525 V 50/60 Hz                                  | $I_{cm}$ | kA | 105   |
| 690 V 50/60 H                                   | $I_c$    | kA | 40  |
| Rated short-circuit breaking capacity $I_{cn}$  | $I_{cn}$ |    |   |
| $I_{cu}$ to IEC/EN 60947 test cycle O-t-CO      | $I_{cu}$ | kA |   |
| 240 V 50/60 Hz                                  | $I_{cu}$ | kA | 150   |
| 400/415 V 50/60 Hz                              | $I_{cu}$ | kA | 150   |
| 440 V 50/60 Hz                                  | $I_{cu}$ | kA | 130   |
| 525 V 50/60 Hz                                  | $I_{cu}$ | kA | 50  |
| $I_{cs}$ to IEC/EN 60947 test cycle O-t-CO-t-CO | $I_{cs}$ | kA |   |
| 240 V 50/60 Hz                                  | $I_{cs}$ | kA | 150   |
| 400/415 V 50/60 Hz                              | $I_{cs}$ | kA | 150   |
| 440 V 50/60 Hz                                  | $I_{cs}$ | kA | 130   |
| 525 V 50/60 Hz                                  | $I_{cs}$ | kA | 37.5  |
| 690 V 50/60 Hz                                  | $I_{cs}$ | kA | 5   |
|   |          |    | Maximum back-up fuse, if the expected short-circuit currents at the installation location exceed the switching capacity of the circuit-breaker. |
| Rated short-time withstand current              |          |    |   |
| t = 0.3 s                                       | $I_{cw}$ | kA | 1.9   |
| t = 1 s   | $I_{cw}$ | kA | 1.9   |

|   |            |       |       |
|---|------------|-------|-------|
| Utilization category to IEC/EN 60947-2                                      |            |       | A     |
| Rated making and breaking capacity  |            |       |       |
| Rated operational current   | $I_e$      | A     |       |
| AC-1  |            |       |       |
| 380 V 400 V   | $I_e$      | A     | 100   |
| 415 V   | $I_e$      | A     | 300   |
| 690 V   | $I_e$      | A     | 100   |
| AC--3   |            |       |       |
| 380 V 400 V   | $I_e$      | A     | 100   |
| 415 V   | $I_e$      | A     | 100   |
| 660 V 690 V   | $I_e$      | A     | 100   |
| Lifespan, mechanical(of which max. 50 % trip by shunt/undervoltage release) | Operations |       | 20000 |
| Lifespan, electrical  |            |       |       |
| AC-1  |            |       |       |
| 400 V 50/60 Hz  | Operations |       | 10000 |
| 415 V 50/60 Hz  | Operations |       | 10000 |
| 690 V 50/60 Hz  | Operations |       | 7500  |
| AC--3   |            |       |       |
| 400 V 50/60 Hz  | Operations |       | 6500  |
| 415 V 50/60 Hz  | Operations |       | 6500  |
| 690 V 50/60 Hz  | Operations |       | 5000  |
| Max. operating frequency  |            | Ops/h | 120   |
| Total downtime in a short-circuit   |            | ms    | < 10  |

### Terminal capacity

|   |      |                 |   |
|---|------|-----------------|---|
| Standard equipment  |      |                 | Screw connection  |
| Optional accessories                                      |      |                 | Box terminal<br>Tunnel terminal<br>connection on rear   |
| Round copper conductor                                    |      |                 |   |
| Box terminal  |      |                 |   |
| Solid   |      | mm <sup>2</sup> | 1 x (10 - 16)<br>2 x (6-16)   |
| Stranded  |      | mm <sup>2</sup> | 1 x (25 - 185)<br>2 x (25-70)   |
| Tunnel terminal   |      |                 |   |
| Solid   |      | mm <sup>2</sup> | 1 x 16  |
| Stranded  |      | mm <sup>2</sup> |   |
| Stranded  |      | mm <sup>2</sup> | 1 x (25 - 185)  |
| Bolt terminal and rear-side connection                    |      |                 |   |
| Direct on the switch                                      |      |                 |   |
| Solid   |      | mm <sup>2</sup> | 1 x (10 - 16)<br>2 x (10 - 16)  |
| Stranded  |      | mm <sup>2</sup> | 1 x (25 - 185)<br>2 x (25 - 70)   |
| Al conductors, Cu cable                                   |      |                 |   |
| Solid   |      | mm <sup>2</sup> | 1 x 16  |
| Stranded  |      | mm <sup>2</sup> |   |
| Stranded  |      | mm <sup>2</sup> | 1 x (25 - 185) <sup>2)</sup>  |
|   |      |                 | <sup>2)</sup> Up to 240 mm <sup>2</sup> can be connected depending on the cable manufacturer. |
| Bolt terminal and rear-side connection                    |      |                 |   |
| Flat copper strip, with holes                             | min. | mm              | 2 x 16 x 0.8  |
| Flat copper strip, with holes                             | max. | mm              | 10 x 24 x 0.8   |
| Cu strip (number of segments x width x segment thickness) |      |                 |   |
| Box terminal  |      |                 |   |
|   | min. | mm              | 2 x 9 x 0.8   |

|  |      |                 |                                      |
|--|------|-----------------|--------------------------------------|
|  | max. | mm              | 10 x 16 x 0.8<br>(2x) 8 x 15.5 x 0,8 |
| Bolt terminal and rear-side connection |      |                 |                                      |
| Flat copper strip, with holes          | min. | mm              | 2 x 16 x 0.8                         |
| Flat copper strip, with holes          | max. | mm              | 10 x 24 x 0.8                        |
| Copper busbar (width x thickness)      | mm   |                 |                                      |
| Bolt terminal and rear-side connection |      |                 |                                      |
| Screw connection                       |      |                 | M8                                   |
| Direct on the switch                   |      |                 |                                      |
|  | min. | mm              | 16 x 5                               |
|  | max. | mm              | 24 x 8                               |
| Control cables                         |      |                 |                                      |
|  |      | mm <sup>2</sup> | 1 x (0.75 - 2.5)<br>2 x (0.75 - 1.5) |

## Design verification as per IEC/EN 61439

|  |                  |    |  |
|--|------------------|----|--|
| Technical data for design verification   |                  |    |  |
| Rated operational current for specified heat dissipation   | I <sub>n</sub>   | A  | 100  |
| Equipment heat dissipation, current-dependent  | P <sub>vid</sub> | W  | 8.25   |
| Operating ambient temperature min.   |                  | °C | -25  |
| Operating ambient temperature max.   |                  | °C | 70   |
| IEC/EN 61439 design verification   |                  |    |  |
| 10.2 Strength of materials and parts   |                  |    |  |
| 10.2.2 Corrosion resistance  |                  |    | Meets the product standard's requirements.   |
| 10.2.3.1 Verification of thermal stability of enclosures   |                  |    | Meets the product standard's requirements.   |
| 10.2.3.2 Verification of resistance of insulating materials to normal heat   |                  |    | Meets the product standard's requirements.   |
| 10.2.3.3 Verification of resistance of insulating materials to abnormal heat and fire due to internal electric effects |                  |    | Meets the product standard's requirements.   |
| 10.2.4 Resistance to ultra-violet (UV) radiation   |                  |    | Meets the product standard's requirements.   |
| 10.2.5 Lifting   |                  |    | Does not apply, since the entire switchgear needs to be evaluated.   |
| 10.2.6 Mechanical impact   |                  |    | Does not apply, since the entire switchgear needs to be evaluated.   |
| 10.2.7 Inscriptions  |                  |    | Meets the product standard's requirements.   |
| 10.3 Degree of protection of ASSEMBLIES  |                  |    | Does not apply, since the entire switchgear needs to be evaluated.   |
| 10.4 Clearances and creepage distances   |                  |    | Meets the product standard's requirements.   |
| 10.5 Protection against electric shock   |                  |    | Does not apply, since the entire switchgear needs to be evaluated.   |
| 10.6 Incorporation of switching devices and components   |                  |    | Does not apply, since the entire switchgear needs to be evaluated.   |
| 10.7 Internal electrical circuits and connections  |                  |    | Is the panel builder's responsibility.   |
| 10.8 Connections for external conductors   |                  |    | Is the panel builder's responsibility.   |
| 10.9 Insulation properties   |                  |    |  |
| 10.9.2 Power-frequency electric strength   |                  |    | Is the panel builder's responsibility.   |
| 10.9.3 Impulse withstand voltage   |                  |    | Is the panel builder's responsibility.   |
| 10.9.4 Testing of enclosures made of insulating material   |                  |    | Is the panel builder's responsibility.   |
| 10.10 Temperature rise   |                  |    | The panel builder is responsible for the temperature rise calculation. Eaton will provide heat dissipation data for the devices. |
| 10.11 Short-circuit rating   |                  |    | Is the panel builder's responsibility. The specifications for the switchgear must be observed.                                   |
| 10.12 Electromagnetic compatibility  |                  |    | Is the panel builder's responsibility. The specifications for the switchgear must be observed.                                   |
| 10.13 Mechanical function  |                  |    | The device meets the requirements, provided the information in the instruction leaflet (IL) is observed.                         |

## Technical data ETIM 6.0

|  |    |           |
|--|----|-----------|
| Low-voltage industrial components (EG000017) / Power circuit-breaker for trafo/generator/installation prot. (EC000228)   |    |           |
| Electric engineering, automation, process control engineering / Low-voltage switch technology / Circuit breaker (LV < 1 kV) / Circuit breaker for power transformer, generator and system protection (ecl@ss8.1-27-37-04-09 [AJZ716010]) |    |           |
| Rated permanent current I <sub>u</sub>   | A  | 100       |
| Rated voltage  | V  | 690 - 690 |
| Rated short-circuit breaking capacity I <sub>cu</sub> at 400 V, 50 Hz  | kA | 150       |

|   |   |  |
|---|---|--|
| Overload release current setting                          | A | 50 - 100                                 |
| Adjustment range short-term delayed short-circuit release | A | 100 - 1000                               |
| Adjustment range undelayed short-circuit release          | A | 1200 - 1200                              |
| Integrated earth fault protection                         |   | No                                       |
| Type of electrical connection of main circuit             |   | Screw connection                         |
| Device construction                                       |   | Built-in device fixed built-in technique |
| Suitable for DIN rail (top hat rail) mounting             |   | No                                       |
| DIN rail (top hat rail) mounting optional                 |   | Yes                                      |
| Number of auxiliary contacts as normally closed contact   |   | 0  |
| Number of auxiliary contacts as normally open contact     |   | 0  |
| Number of auxiliary contacts as change-over contact       |   | 0  |
| Switched-off indicator available                          |   | No                                       |
| With under voltage release                                |   | No                                       |
| Number of poles   |   | 4  |
| Position of connection for main current circuit           |   | Front side                               |
| Type of control element                                   |   | Rocker lever                             |
| Complete device with protection unit                      |   | Yes                                      |
| Motor drive integrated                                    |   | No                                       |
| Motor drive optional                                      |   | Yes                                      |
| Degree of protection (IP)                                 |   | IP20                                     |

# Characteristics

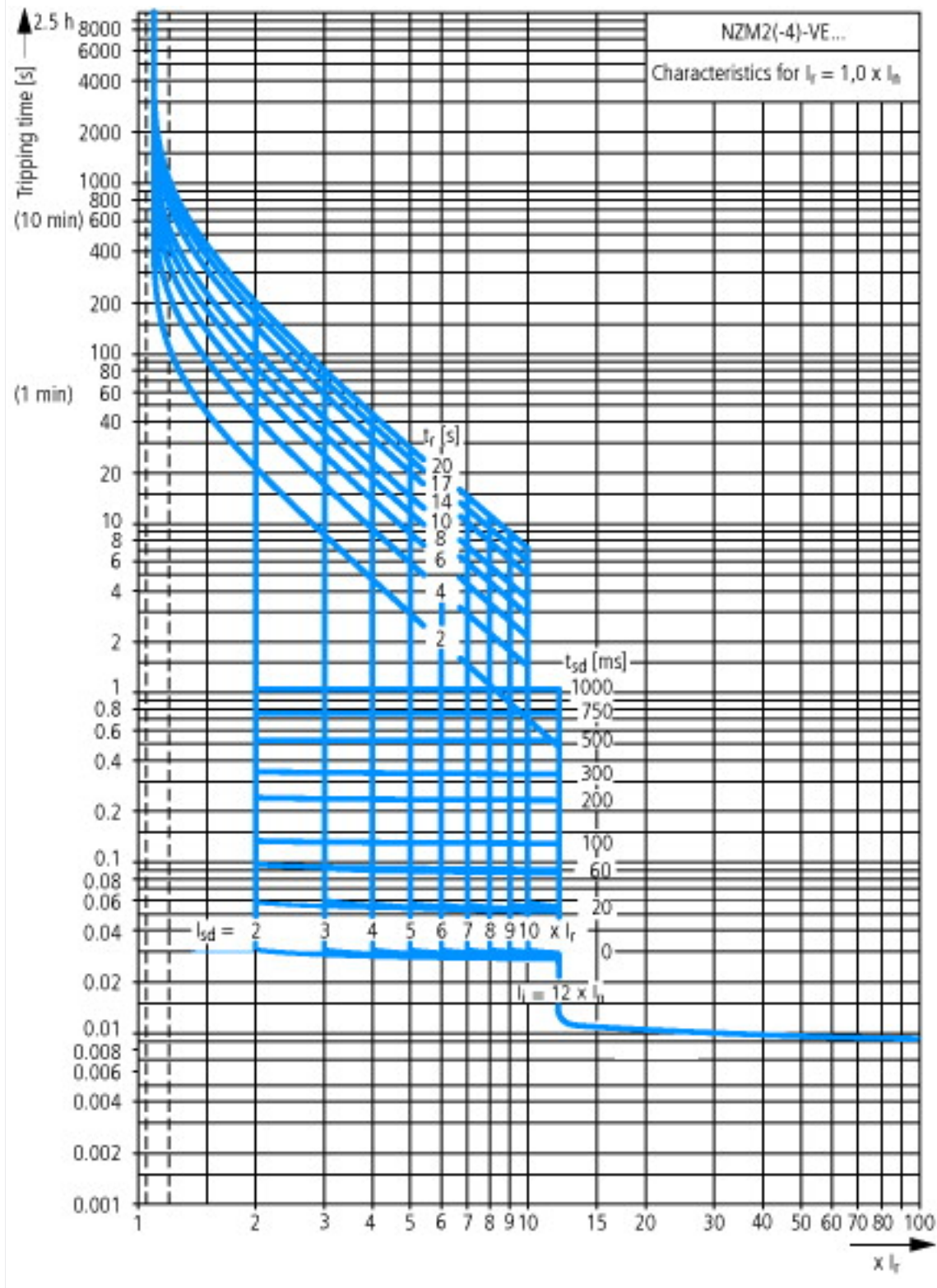

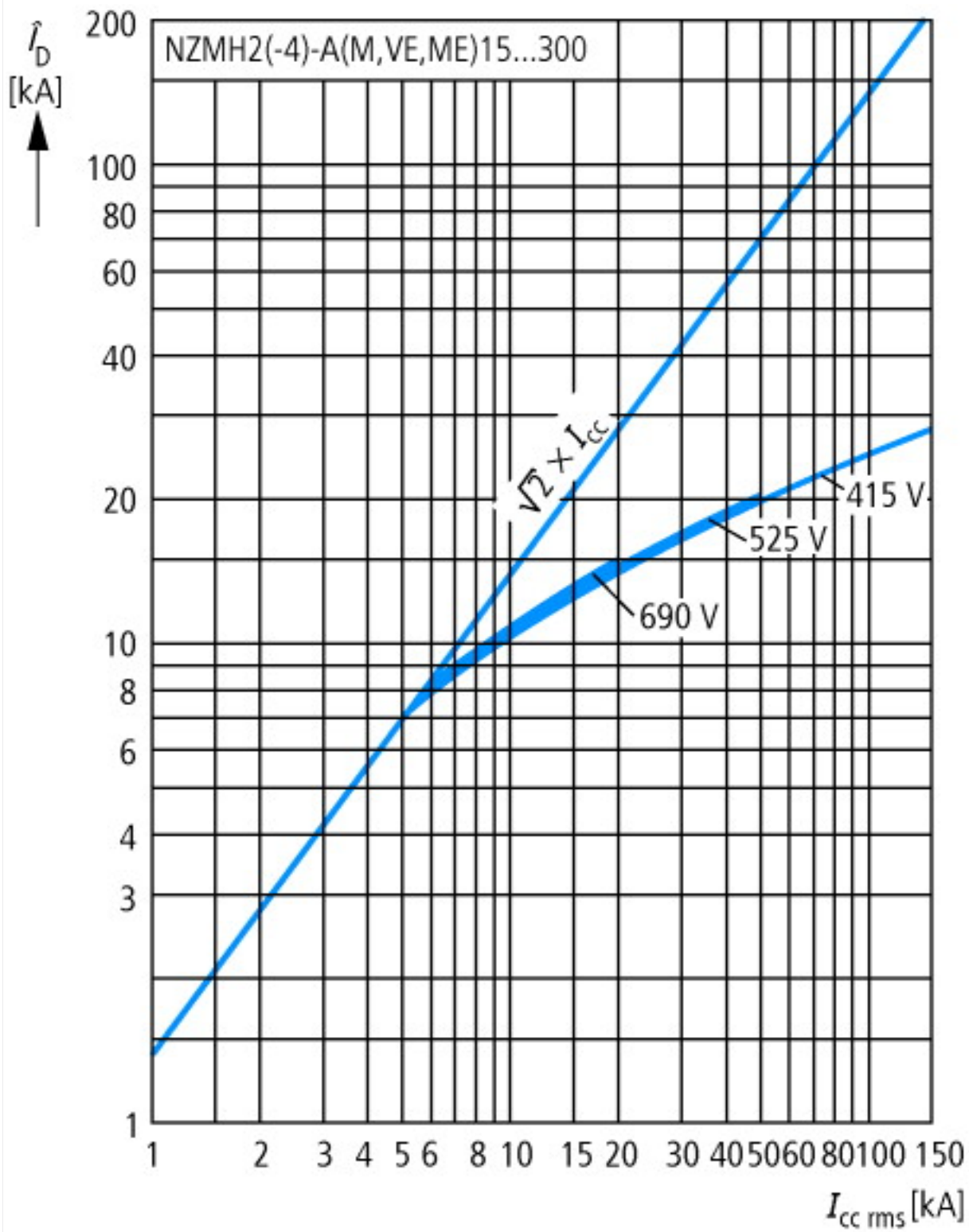

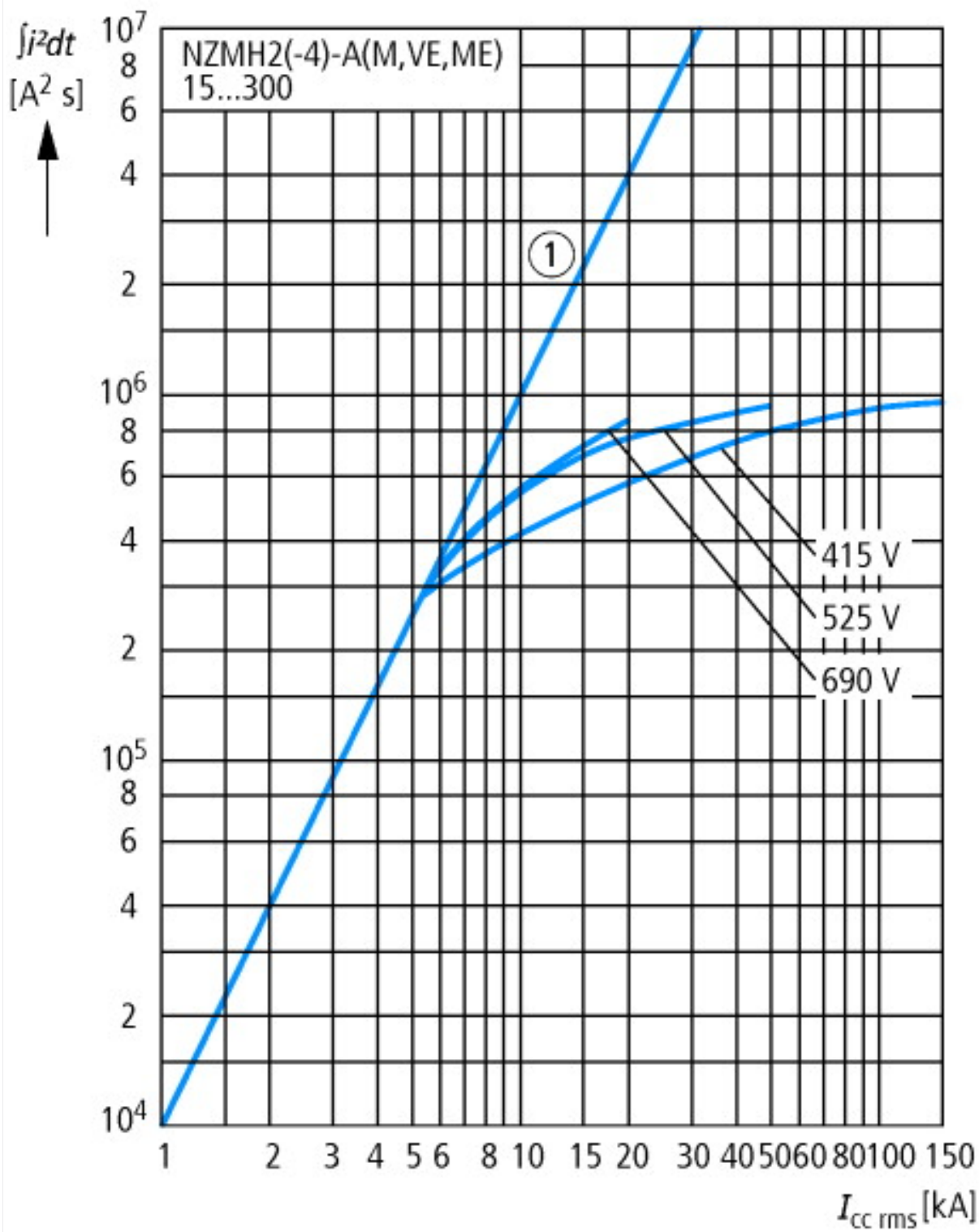



## Dimensions

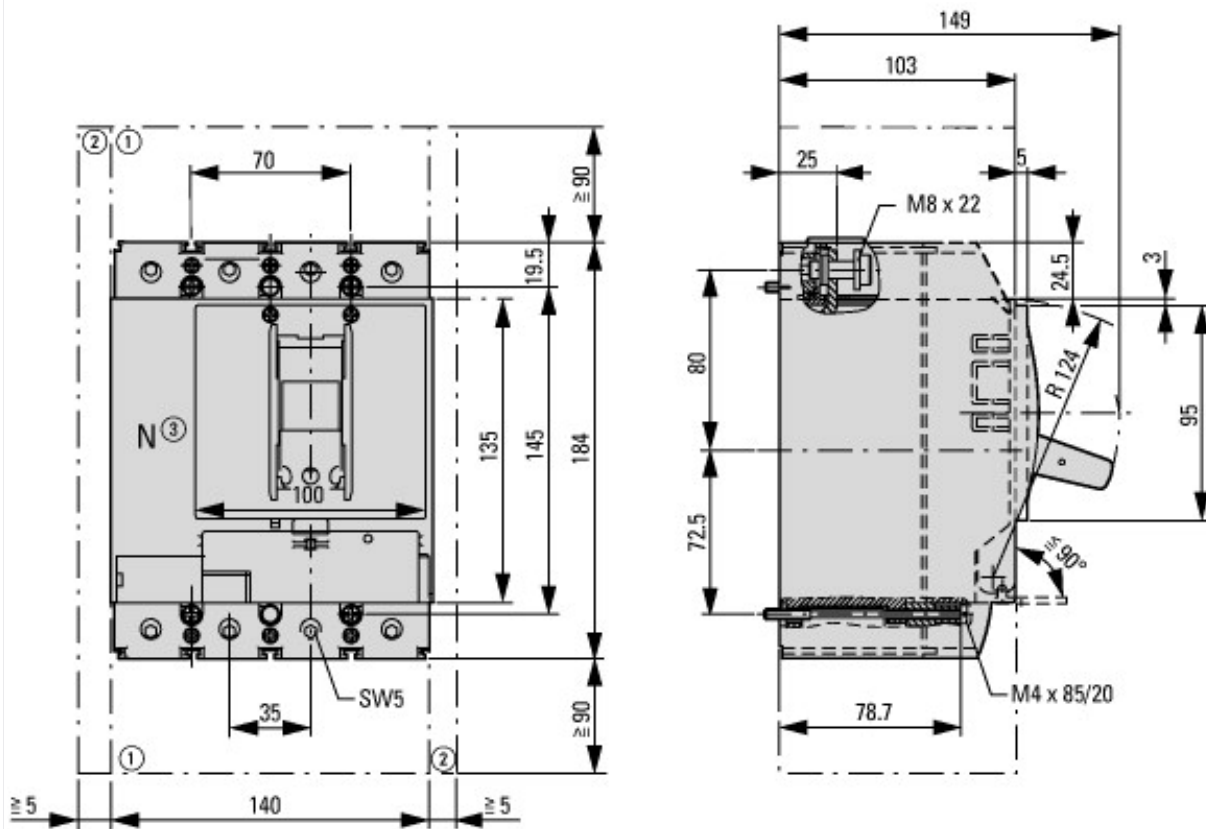

- ① Blow out area, minimum clearance to adjacent parts
- ② Minimum clearance to adjacent parts

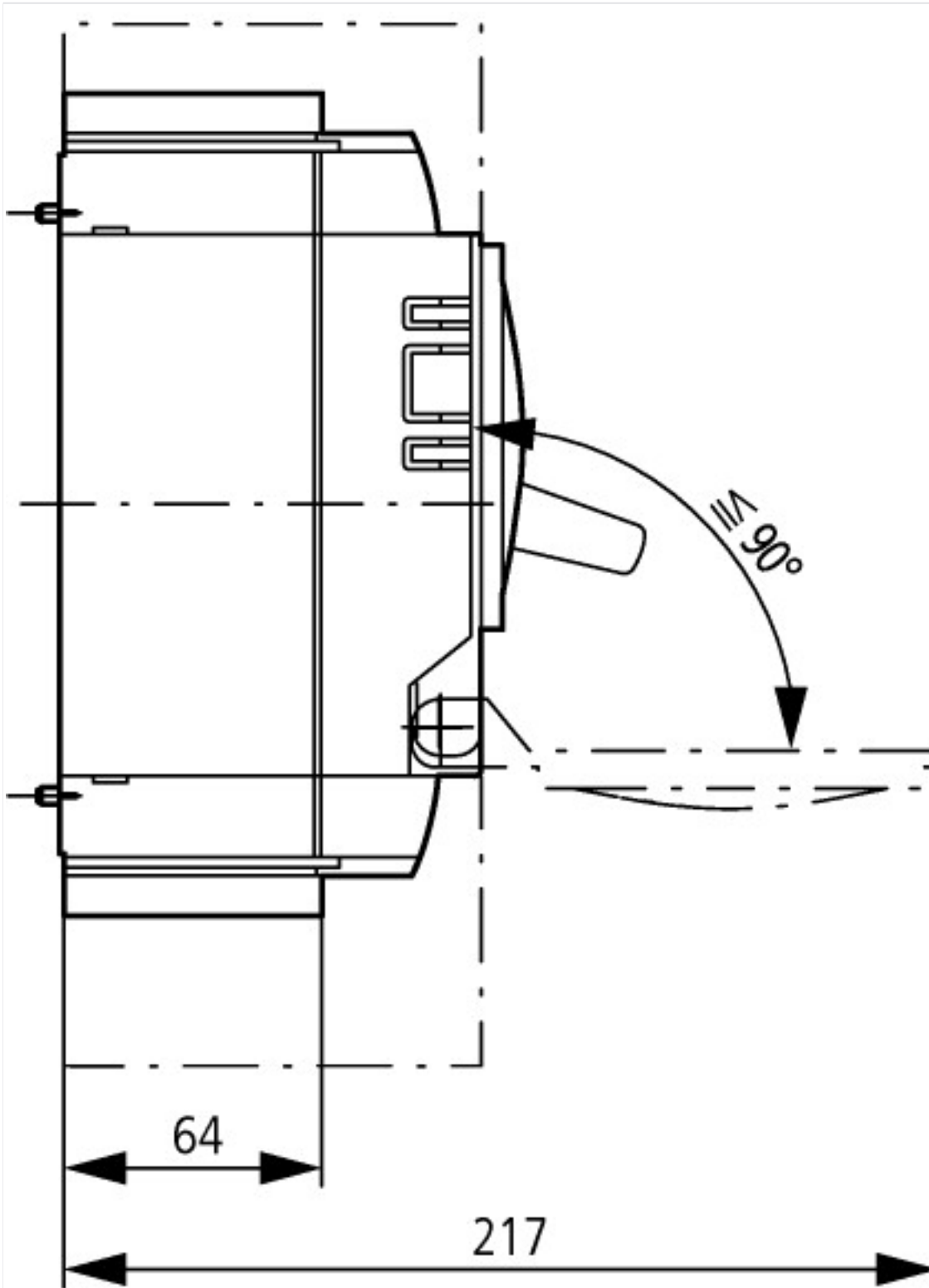

### Additional product information (links)

#### IL01206006Z (AWA1230-1916) Circuit-Breaker, basic unit

IL01206006Z (AWA1230-1916) Circuit-Breaker, basic unit [ftp://ftp.moeller.net/DOCUMENTATION/AWA\\_INSTRUCTIONS/IL01206006Z2015\\_11.pdf](ftp://ftp.moeller.net/DOCUMENTATION/AWA_INSTRUCTIONS/IL01206006Z2015_11.pdf)

Weight <http://ecat.moeller.net/flip-cat/?edition=HPLEN&startpage=17.171>

Temperature dependency, Derating <http://ecat.moeller.net/flip-cat/?edition=HPLEN&startpage=17.172>

Effective power loss <http://ecat.moeller.net/flip-cat/?edition=HPLEN&startpage=17.174>

CurveSelect characteristics program <http://www.eaton.eu/DE/Europe/Electrical/CustomerSupport/ConfigurationTools/CharacteristicsProgram/index.htm>

Eaton configurator <http://www.eaton.eu/DE/Europe/Electrical/CustomerSupport/ConfigurationTools/ConfiguratorCircuitBreaker/index.htm>