



Measuring and communication module, 300A, 4p

Part no. NZM2-4-XMC-MB
Article no. 129965

Delivery program

Product range			Accessories
Accessories			Measuring modules
Accessories			Accessories, diagnostics & communication
Description			<p>For measuring current, voltage, power and energy.</p> <p>The module has three built-in current transformers and three voltage taps, which are contacted with self-tapping screws, which penetrate the the cable insulation.</p> <p>Power supply 24 VDC</p> <p>Two SO pulse outputs</p> <p>Modbus interface (Slave)</p> <p>The total energy consumption value is permanently stored in the module.</p> <p>Display device NZM-XMC-DISP can be connected for local indication of the readings.</p>
Number of poles			4 pole
For use with			NZM 2  300 A
Rated operating frequency			AC 50/60 Hz
Standard/Approval			IEC
Construction size			NZM2
Notes			
The minimum clearances relative to the NZM circuit-breaker need to be maintained for installation.			
The module can be installed on the input or outgoer side and can be set up using the Eaton Modbus Configurator(www.eaton.eu).			

Technical data

General

Dimensions (W x H x D)		mm	251 x 132 x 91
Weight		kg	0.975

Environmental conditions

Operating temperature		°C	-15 - +55
Relative humidity, non-condensing (IEC/EN 60068-2-30)		%	5 - 95
Ambient temperature			
Storage	9	°C	-40 - 80
Suitable for height			2000
Degree of Protection			IP20

Power supply module

Supply voltage	U _s		24 V DC
Max. supply current		mA	200
Type of conductor			Phoenix Contact GMVSTBR 2.5-2-ST-7.62

Power supply

Rated operational voltage	U _e	V AC	72 - 600
Surge voltage		kV	8
Max. voltage		V AC	600
Impedance	R	kΩ	1
Frequency		Hz	45 - 65
Accuracy			0.95 % measurement + 0.05 % FS
Overvoltage category			Category IV - 600 V

Max. current

Rated operational current	I _e	A AC	1 - 300
Max. current	I _{max}	A	30
Frequency			45 - 200

Power monitoring PM

Accuracy			0.95 % measurement + 0.05 % FS
Output type			NPN-isolated transistor
Transistor voltage			80 / 0.4
Transistor current			50 / 10
Potential isolation			3
Switching Frequency		Hz	4
Pulse duration		ms	500 / 20
Power pulse rate		Pulse/ kWh	1

Digital outputs

Rated voltage	U _e	V	350
at state "1"	I _e	A	120

SBI interface RS485

Potential isolation			3
---------------------	--	--	---

Design verification as per IEC/EN 61439

IEC/EN 61439 design verification			
10.2 Strength of materials and parts			
10.2.2 Corrosion resistance			Meets the product standard's requirements.
10.2.3.1 Verification of thermal stability of enclosures			Meets the product standard's requirements.
10.2.3.2 Verification of resistance of insulating materials to normal heat			Meets the product standard's requirements.
10.2.3.3 Verification of resistance of insulating materials to abnormal heat and fire due to internal electric effects			Meets the product standard's requirements.
10.2.4 Resistance to ultra-violet (UV) radiation			Meets the product standard's requirements.
10.2.5 Lifting			Does not apply, since the entire switchgear needs to be evaluated.
10.2.6 Mechanical impact			Does not apply, since the entire switchgear needs to be evaluated.
10.2.7 Inscriptions			Meets the product standard's requirements.
10.3 Degree of protection of ASSEMBLIES			Does not apply, since the entire switchgear needs to be evaluated.
10.4 Clearances and creepage distances			Meets the product standard's requirements.
10.5 Protection against electric shock			Does not apply, since the entire switchgear needs to be evaluated.
10.6 Incorporation of switching devices and components			Does not apply, since the entire switchgear needs to be evaluated.
10.7 Internal electrical circuits and connections			Is the panel builder's responsibility.
10.8 Connections for external conductors			Is the panel builder's responsibility.
10.9 Insulation properties			
10.9.2 Power-frequency electric strength			Is the panel builder's responsibility.
10.9.3 Impulse withstand voltage			Is the panel builder's responsibility.
10.9.4 Testing of enclosures made of insulating material			Is the panel builder's responsibility.
10.10 Temperature rise			The panel builder is responsible for the temperature rise calculation. Eaton will provide heat dissipation data for the devices.
10.11 Short-circuit rating			Is the panel builder's responsibility. The specifications for the switchgear must be observed.
10.12 Electromagnetic compatibility			Is the panel builder's responsibility. The specifications for the switchgear must be observed.
10.13 Mechanical function			The device meets the requirements, provided the information in the instruction leaflet (IL) is observed.

Technical data ETIM 6.0

PLC's (EG000024) / Fieldbus, decentr. periphery - communication module (EC001604)			
Electric engineering, automation, process control engineering / Control / Field bus, decentralized peripheral / Field bus, decentralized peripheral - communications module (ecl@ss8.1-27-24-26-08 [BAA073010])			
Supply voltage AC 50 Hz		V	0 - 0
Supply voltage AC 60 Hz		V	0 - 0
Supply voltage DC		V	24 - 24
Voltage type of supply voltage			DC
Supporting protocol for TCP/IP			No
Supporting protocol for PROFIBUS			No
Supporting protocol for CAN			No

Supporting protocol for INTERBUS		No
Supporting protocol for ASI		No
Supporting protocol for KNX		No
Supporting protocol for MODBUS		Yes
Supporting protocol for Data-Highway		No
Supporting protocol for DeviceNet		No
Supporting protocol for SUCONET		No
Supporting protocol for LON		No
Supporting protocol for SERCOS		No
Supporting protocol for PROFINET IO		No
Supporting protocol for PROFINET CBA		No
Supporting protocol for Foundation Fieldbus		No
Supporting protocol for EtherNet/IP		No
Supporting protocol for AS-Interface Safety at Work		No
Supporting protocol for DeviceNet Safety		No
Supporting protocol for INTERBUS-Safety		No
Supporting protocol for PROFIsafe		No
Supporting protocol for SafetyBUS p		No
Supporting protocol for other bus systems		No
Radio standard Bluetooth		No
Radio standard WLAN 802.11		No
Radio standard GPRS		No
Radio standard GSM		No
Radio standard UMTS		No
IO link master		No
System accessory		Yes
Degree of protection (IP)		IP20
With potential separation		Yes
Fieldbus connection over separate bus coupler possible		Yes
Rail mounting possible		No
Wall mounting/direct mounting		Yes
Front build in possible		No
Rack-assembly possible		No
Suitable for safety functions		No
Category according to EN 954-1		-
SIL according to IEC 61508		None
Performance level acc. to EN ISO 13849-1		None
Appendant operation agent (Ex ia)		No
Appendant operation agent (Ex ib)		No
Explosion safety category for gas		None
Explosion safety category for dust		None
Width	mm	250
Height	mm	132
Depth	mm	91

Dimensions

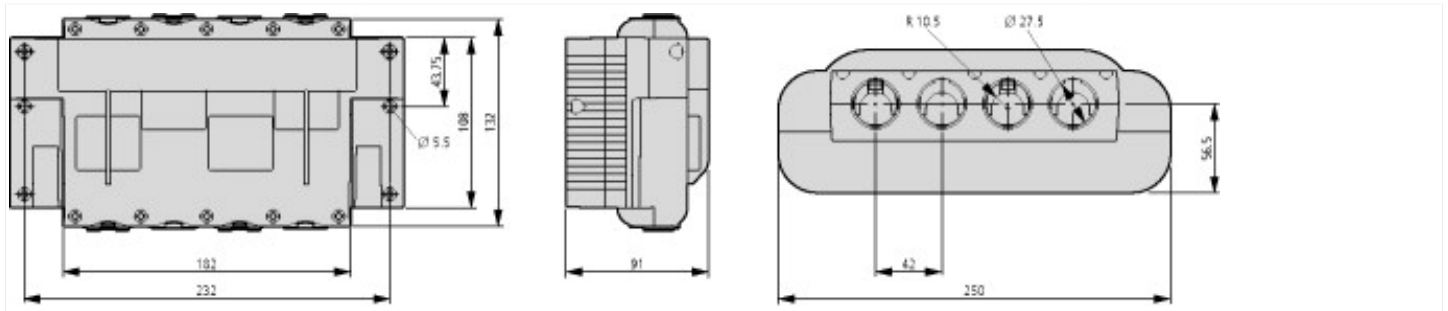

Additional product information (links)

12/13 IL01219006Z (replaces AWA1230-2617)	
12/13 IL01219006Z (replaces AWA1230-2617)	ftp://ftp.moeller.net/DOCUMENTATION/AWA_INSTRUCTIONS/IL01219006Z2013_12.pdf
05/13 MN01219001Z (replaces AWB1230-1630en)	
05/13 MN01219001Z (ersetzt AWB1230-1630de) - Deutsch	ftp://ftp.moeller.net/DOCUMENTATION/AWB_MANUALS/MN01219001Z_DE.pdf
05/13 MN01219001Z (replaces AWB1230-1630en) - English	ftp://ftp.moeller.net/DOCUMENTATION/AWB_MANUALS/MN01219001Z_EN.pdf