



Central processing unit/power supply unit, 24 V DC, expandable, without easyNet, double memory like MFD-CP 8

Part no. MFD-CP10-ME
Article no. 133801

Delivery program

Product range		Multi-function-display MFD-Titan
Basic function		Power supply unit/CPU modules
Subrange		CPU modules
Supply voltage		24 V DC
easyNet/easyLink		ohne easyNet
Description		can be combined with display/operating unit MFD-80-.. and I/O module Expandable: Digital/analog inputs/outputs and AS-Interface, PROFIBUS-DP, CANopen®, DeviceNet bus systems Bussystem easyNet optional on board Program and screen memory Delivery with user program possible with MFD-COMBINATION product (Article no. 201801)
Description		double program and screen memory like MFD-CP8...
Connection type		Spring-cage terminals
Degree of Protection		IP20

Technical data

General

Standards		EN 61000-6-1/-2/-3/-4, IEC 60068-2-6, IEC 60068-2-27
Dimensions (W x H x D)	mm	107.5 x 90 x 30
Weight	kg	0.145
Mounting		Fitted on the fixing shaft of the display or on top-hat rail according to IEC/EN 60715, 35 mm deep (without display)

Terminal capacities

Solid	mm ²	0.2/4 (AWG 24 - 12)
Flexible with ferrule	mm ²	0.2/2.5 (AWG 24 - 12)
Standard screwdriver	mm	3.5 x 0.6

Climatic environmental conditions

Operating ambient temperature	°C	-25 to 55, cold as per IEC 60068-2-1, heat as per IEC 60068-2-2
Condensation		Take appropriate measures to prevent condensation
Storage	°C	- 40 - 70
Relative humidity, non-condensing (IEC/EN 60068-2-30)	%	5 - 95
Air pressure (operation)	hPa	795 - 1080

Ambient conditions, mechanical

Protection type (IEC/EN 60529, EN50178, VBG 4)		IP20
Vibrations (IEC/EN 60068-2-6)	Hz	
Constant amplitude 0.15 mm	Hz	10 - 57
Constant acceleration 2 g	Hz	57 - 150
Mechanical shock resistance (IEC/EN 60068-2-27) semi-sinusoidal 15 g/11 ms	Impacts	18
Drop to IEC/EN 60068-2-31	Drop height	mm
Free fall, packaged (IEC/EN 60068-2-32)	m	1
Mounting position		Vertical or horizontal

Electromagnetic compatibility (EMC)

Electrostatic discharge (IEC/EN 61000-4-2, Level 3, ESD)	kV	
Air discharge	kV	8
Contact discharge	kV	6
Electromagnetic fields (RFI) to IEC EN 61000-4-3	V/m	10
Radio interference suppression		EN 55011 Class B, EN 55022 Class B
Burst Impulse (IEC/EN 61000-4-4, Level 3)		
Supply cable	kV	2
Signal lines	kV	2
Power pulses (surge) (IEC/EN 61000-4-5)	kV	2 (supply cables, symmetrical)

power pulses (surge) (IEC/EN 61000-4-5, level 2)	kV	2 (supply cables symmetrical, MFD-AC-CP8..)
Immunity to line-conducted interference to (IEC/EN 61000-4-6)	V	10

Insulation resistance

Clearance in air and creepage distances		EN 50178, UL 508, CSA C22.2, No. 142
Insulation resistance		EN 50178

Back-up of real-time clock

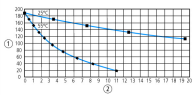
Back-up of real-time clock			
			<p>① Backup time (hours) with fully charged double layer capacitor</p> <p>② Service life (years)</p>
Accuracy of the real-time clock	s/day	Normally ±5 s/day (±0.5 h/year)	

Repetition accuracy of timing relays

Accuracy of timing relays (of values)	%	± 0.02
Resolution		
Range "S"	ms	5
Range "M:S"	s	1
Range "H:M"	min	1

Retentive memory

Write cycles of the retentive memory		10 ¹⁰ (read/write cycles)
--------------------------------------	--	--------------------------------------

Power supply

Rated operational voltage	U _e	V	24 DC (-15/+20 %)
Admissible range		V DC	20.4 - 28.8
Residual ripple		%	 5
Input current			
at 24 V DC		mA	Normally 200
Voltage dips		ms	10
Power loss			
Heat dissipation at 24 V DC		W	3.4
Note on heat dissipation			Current consumption at 24 V DC

Network easyNet

Stations	Number	max. 8
Data transfer rate/distance		1000 kBit/s, 6 m 500 Kbit/s, 25 m 250 Kbit/s, 40 m 125 kBit/s, 125 m 50 Kbit/s, 300 m 20 Kbit/s, 700 m 10 Kbit/s, 1000 m
Distance	m	5
Potential isolation		
From power supply		yes
From the inputs		yes
From the outputs		yes
to PC interface, memory card, easyNet, easyLink		yes
Bus termination (first and last station)		yes
Connection technique		RJ45, 8-pole

Design verification as per IEC/EN 61439

Technical data for design verification			
Rated operational current for specified heat dissipation	I _n	A	0
Heat dissipation per pole, current-dependent	P _{vid}	W	0
Equipment heat dissipation, current-dependent	P _{vid}	W	0
Static heat dissipation, non-current-dependent	P _{vs}	W	3.4
Heat dissipation capacity	P _{diss}	W	0
Operating ambient temperature min.		°C	-25
Operating ambient temperature max.		°C	55
IEC/EN 61439 design verification			

10.2 Strength of materials and parts		
10.2.2 Corrosion resistance		Meets the product standard's requirements.
10.2.3.1 Verification of thermal stability of enclosures		Meets the product standard's requirements.
10.2.3.2 Verification of resistance of insulating materials to normal heat		Meets the product standard's requirements.
10.2.3.3 Verification of resistance of insulating materials to abnormal heat and fire due to internal electric effects		Meets the product standard's requirements.
10.2.4 Resistance to ultra-violet (UV) radiation		Meets the product standard's requirements.
10.2.5 Lifting		Does not apply, since the entire switchgear needs to be evaluated.
10.2.6 Mechanical impact		Does not apply, since the entire switchgear needs to be evaluated.
10.2.7 Inscriptions		Meets the product standard's requirements.
10.3 Degree of protection of ASSEMBLIES		Meets the product standard's requirements.
10.4 Clearances and creepage distances		Meets the product standard's requirements.
10.5 Protection against electric shock		Does not apply, since the entire switchgear needs to be evaluated.
10.6 Incorporation of switching devices and components		Does not apply, since the entire switchgear needs to be evaluated.
10.7 Internal electrical circuits and connections		Is the panel builder's responsibility.
10.8 Connections for external conductors		Is the panel builder's responsibility.
10.9 Insulation properties		
10.9.2 Power-frequency electric strength		Is the panel builder's responsibility.
10.9.3 Impulse withstand voltage		Is the panel builder's responsibility.
10.9.4 Testing of enclosures made of insulating material		Is the panel builder's responsibility.
10.10 Temperature rise		The panel builder is responsible for the temperature rise calculation. Eaton will provide heat dissipation data for the devices.
10.11 Short-circuit rating		Is the panel builder's responsibility.
10.12 Electromagnetic compatibility		Is the panel builder's responsibility.
10.13 Mechanical function		The device meets the requirements, provided the information in the instruction leaflet (IL) is observed.

Technical data ETIM 6.0

PLC's (EG000024) / Graphic panel (EC001412)		
Electric engineering, automation, process control engineering / Control / Operate and Observe (HMI) / Graphic panel (HMI) (ecl@ss8.1-27-24-23-02 [BAA722010])		
Supply voltage AC 50 Hz	V	0 - 0
Supply voltage AC 60 Hz	V	0 - 0
Supply voltage DC	V	20.4 - 28.8
Voltage type of supply voltage		DC
Number of HW-interfaces industrial Ethernet		0
Number of HW-interfaces PROFINET		0
Number of HW-interfaces RS-232		0
Number of HW-interfaces RS-422		0
Number of HW-interfaces RS-485		0
Number of HW-interfaces serial TTY		0
Number of HW-interfaces USB		0
Number of HW-interfaces parallel		0
Number of HW-interfaces Wireless		0
Number of HW-interfaces other		3
With SW interfaces		Yes
Supporting protocol for TCP/IP		No
Supporting protocol for PROFIBUS		No
Supporting protocol for CAN		No
Supporting protocol for INTERBUS		No
Supporting protocol for ASI		No
Supporting protocol for KNX		No
Supporting protocol for MODBUS		No
Supporting protocol for Data-Highway		No
Supporting protocol for DeviceNet		No
Supporting protocol for SUCONET		No
Supporting protocol for LON		No

Supporting protocol for PROFINET IO		No
Supporting protocol for PROFINET CBA		No
Supporting protocol for SERCOS		No
Supporting protocol for Foundation Fieldbus		No
Supporting protocol for EtherNet/IP		No
Supporting protocol for AS-Interface Safety at Work		No
Supporting protocol for DeviceNet Safety		No
Supporting protocol for INTERBUS-Safety		No
Supporting protocol for PROFIsafe		No
Supporting protocol for SafetyBUS p		No
Supporting protocol for other bus systems		No
Radio standard Bluetooth		No
Radio standard WLAN 802.11		No
Radio standard GPRS		No
Radio standard GSM		No
Radio standard UMTS		No
IO link master		No
Type of display		-
With colour display		No
Number of colours of the display		0
Number of grey-scales/blue-scales of display		0
Screen diagonal	inch	0
Number of pixels, horizontal		0
Number of pixels, vertical		0
Useful project memory/user memory	kByte	64
With numeric keyboard		No
With alpha numeric keyboard		No
Number of function buttons, programmable		9
Number of buttons with LED		0
Number of system buttons		0
With touch screen		No
With message indication		Yes
With message system (incl. buffer and confirmation)		No
Process value representation (output) possible		Yes
Process default value (input) possible		Yes
With recipes		No
Number of password levels		1
Printer output available		No
Number of online languages		256
Additional software components, loadable		Yes
Degree of protection (IP), front side		IP20
Operation temperature	°C	-25 - 55
Rail mounting possible		Yes
Wall mounting/direct mounting		No
Suitable for safety functions		No
Width of the front	mm	0
Height of the front	mm	0
Built-in depth	mm	25

Approvals

Product Standards		IEC/EN see Technical Data; UL 508; CSA C22.2 No. 142-M1987; CSA C22.2 No. 213-M1987; CE marking
UL File No.		E135462
UL Category Control No.		NRAQ
CSA File No.		012528
CSA Class No.		2252-01 + 2258-02

Dimensions

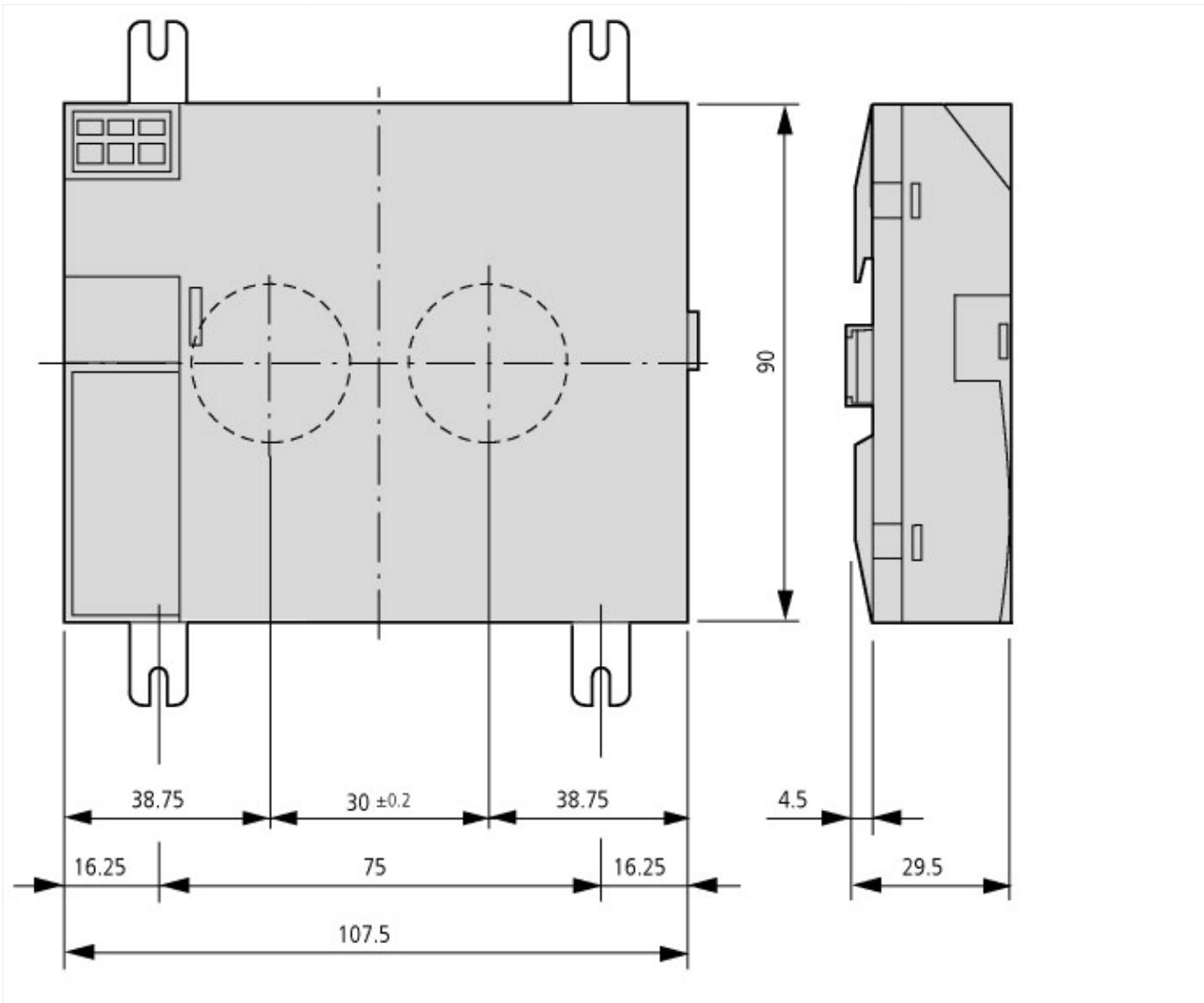

Additional product information (links)

Instruction leaflet "Multi-function display, easy control relays" IL05013014Z (AWA2528-2019)

Instruction leaflet "Multi-function display, easy control relays" IL05013014Z (AWA2528-2019) ftp://ftp.moeller.net/DOCUMENTATION/AWA_INSTRUCTIONS/IL05013014Z2010_11.pdf

Instruction leaflet "power supply unit, communication module" IL05013018Z (AWA2528-2175)

Instruction leaflet "power supply unit, communication module" IL05013018Z (AWA2528-2175) ftp://ftp.moeller.net/DOCUMENTATION/AWA_INSTRUCTIONS/IL05013018Z.pdf

Manual "MFD-Titan multi-function display" MN05002001Z (AWB2528-1480)

Manual "MFD-Titan multi-function display" MN05002001Z (AWB2528-1480) - Deutsch ftp://ftp.moeller.net/DOCUMENTATION/AWB_MANUALS/MN05002001Z_DE.pdf

Manual "MFD-Titan multi-function display" MN05002001Z (AWB2528-1480) - English ftp://ftp.moeller.net/DOCUMENTATION/AWB_MANUALS/MN05002001Z_EN.pdf

Labeleditor (Beschriftungssoftware) <http://downloadcenter.moeller.net/de/software.f6023a63-5acb-42c7-a51c-ccf99091cace>