



Retroreflective sensing sensor, Sn=2m, 4L, 10-30VDC, NPN, PNP, M18, insulated material, M12

Part no. LSO-R18P-B2000-PD
Article no. 281986
Catalog No. -

Delivery program

Basic function			Optical proximity switches
Part group reference			LSO
Product range			Reflected-light barrier
Description			For combination with light-barrier reflector
Operating range	S_d	mm	2000
Style		mm	M18 x 1
Housing			Insulated material
Terminal connection			Plug-in connection M12 x 1
Maximum load current	I_e	mA	150

Technical data

General

Standards			IEC/EN 60947-5-2
Ambient temperature			40 - +70
Degree of Protection			IP67

Characteristics

Range		mm	2000
Rated operating voltage	U_e	V DC	10 - 30
Maximum load current	I_e	mA	< 150
Operating current in the switched state at 24 V DC	I_b	mA	25
Max. operating frequency (resistive load)	f	Hz	160
Overcurrent release		mA	220
Readiness delay	t_v	ms	100
Switching state display		LED	Yellow
Alarm display		LED	Yellow, flashing
Operating voltage display		LED	red
Fault display		LED	Green, flashing
Short-circuit and reverse polarity protection			●
Output function			Programmable
Style			
Threaded barrel		mm	M18 x 1
Connection options			
Cable, open			●
Connector M12, "A"-keyed			●
Enclosure material			
Plastic			PBT
Metal			Stainless steel 1.4301
Enclosure nut tightening torque			
Plastic		Nm	5
Metal		Nm	25

Notes

Switching range S_d [mm] with LSO

The switching range is defined conform to IEC/EN 60947-5-2. It relates to reflected-light beams on a white paper card with a 90 % degree of reflection and

- 100 mm edge length with $S_d < 400$ mm
- 200 mm edge length with $S_d \begin{matrix} \text{---} \\ \text{---} \\ \text{---} \\ \text{---} \\ \text{---} \end{matrix} 400$ mm

Correction factor with LSO as an optical sensor:

Paper, matt white, 200 g/m² 1.0 x S_d

Metal, gloss 1.2...1.6 x S_d

Aluminium, black anodized 1.1...1.8 x S_d

Expanded polystyrene, white 1 x S_d

Cotton, white 0.6 x S_d

PVC, grey 0.5 x S_d

Wood, untreated 0.4 x S_d

Carton, black, gloss 0.3 x S_d

Carton, black, matt 0.1 x S_d

Short-circuit protection monitored

DC-operated proximity switches are proof against short-circuit. The device is not damaged by the effects of a short-circuit. No matter how long its duration. Once the fault has been cleared, the switch is immediately ready for operation again.

Design verification as per IEC/EN 61439

Technical data for design verification			
Operating ambient temperature min.		°C	40
Operating ambient temperature max.		°C	70

Technical data ETIM 6.0

Sensors (EG000026) / Reflection light barrier (EC002717)			
Electric engineering, automation, process control engineering / Binary sensor technology, safety-related sensor technology / Optoelectronic sensor / Reflection light barrier (ecl@ss8.1-27-27-09-02 [AKP251010])			
Pre failure notice			No
With time function			No
Rated switching distance		mm	2000
Max. switching distance		mm	2000
Max. output current		mA	150
Reflector included			No
Analogue output 0 V ... 10 V			No
Analogue output 0 mA ... 20 mA			No
Analogue output 4 mA ... 20 mA			No
Analogue output -10 V ... +10 V			No
With other analog output			No
Setting procedure			Manual adjustment
With communication interface analog			No
With communication interface AS-Interface			No
With communication interface CANOpen			No
With communication interface DeviceNet			No
With communication interface Ethernet			No
With communication interface INTERBUS			No
With communication interface PROFIBUS			No
With communication interface RS-232			No
With communication interface RS-422			No
With communication interface RS-485			No
With communication interface SSD			No
With communication interface SSI			No
Number of semiconductor outputs with signalling function			0
Number of contact energized outputs with signalling function			0
Number of protected semiconductor outputs			0
Number of protected contact energized outputs			0
Type of interface for safety communication			-
Type of electric connection			Connector M12
Type of switching output			PNP
Type of switch function			Programmable/configurable

Operation agent-safety class		-
Explosion safety category for gas		None
Explosion safety category for dust		None
Construction type housing		Cylinder, screw-thread
Width sensor	mm	0
Diameter sensor	mm	0
Height of sensor	mm	0
Length of sensor	mm	59
Switch function		-
Material of optical surface		Plastic
Material housing		Plastic
Max. output current at protected output	mA	0
Min. reflector distance	mm	0
Ambient temperature	°C	-40 - 70
Time of reaction	ms	100
Transmission range of the safety field	m	0
Switching frequency	Hz	160
Type of safety acc. IEC 61496-1		-
Switching voltage of OSSD at state "high"	V	0
Rated control supply voltage Us at AC 50HZ	V	0 - 0
Rated control supply voltage Us at AC 60HZ	V	0 - 0
Rated control supply voltage Us at DC	V	24 - 24
Voltage type		DC
With monitoring function downstream switching devices		No
Laser protection class		None
Wavelength of the sensor	nm	0
Type of light		Infrared light
Light dot	mm ²	0
With restart blockage		No
Suitable for safety functions		No
Degree of protection (IP)		IP67

Dimensions

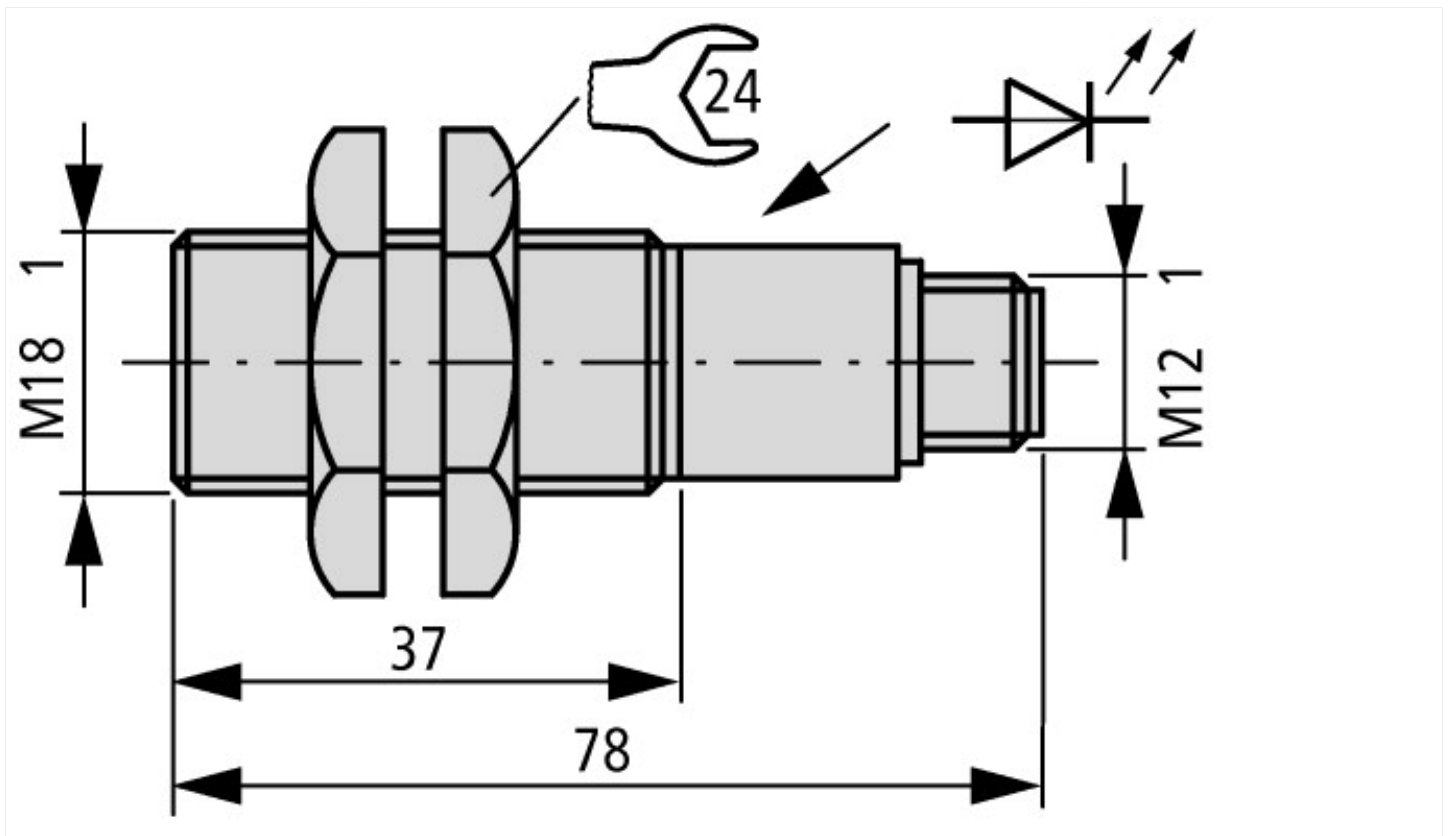

Additional product information (links)

AWA1360-2158 Optical Proximity Switches

AWA1360-2158 Optical Proximity Switches

ftp://ftp.moeller.net/DOCUMENTATION/AWA_INSTRUCTIONS/21580404.pdf