



Neutral terminal

Part no. K-CI-K5
Article no. 218488

Delivery program

Product range			CI-K small enclosures
Basic function			Basic enclosures
Accessories			Insulated individual terminals
Product range			Accessories
Basic function			Neutral terminals
Part group reference			T5 P3
Rated uninterrupted current	I_u	A	150
Rated operational voltage	U_e	V	690
For use with			For connection of a 5th conductor CI-K5 T5-.../15, CI-K5-T5-... P3-.../15
Description			With PE, N adhesive labels For snap-fitting onto mounting rail
Terminal capacity		mm ²	2 x 50 mm ² Round solid copper conductor, 2.5 - 50 mm ² Round stranded copper conductor, 2.5 - 50 mm ² Round flexible copper conductor with ferrule, 2.5 - 35 mm ² Cu ribbon cable, 3 x 9 x 0.8 mm
For use with			Nockenschalter T, Lasttrennschalter P Nockenschalter T Lasttrennschalter P CI-K5
mechanical values			Stripping length 50 mm ² , 16 mm Screw heads internal hex, 5 mm

Design verification as per IEC/EN 61439

Technical data for design verification			
Rated operational current for specified heat dissipation	I_n	A	100
Heat dissipation per pole, current-dependent	P_{vid}	W	7.5
Equipment heat dissipation, current-dependent	P_{vid}	W	0
Static heat dissipation, non-current-dependent	P_{vs}	W	0
Heat dissipation capacity	P_{diss}	W	0
Operating ambient temperature min.		°C	-25
Operating ambient temperature max.		°C	70
IEC/EN 61439 design verification			
10.2 Strength of materials and parts			
10.2.2 Corrosion resistance			
10.2.3.1 Verification of thermal stability of enclosures			Meets the product standard's requirements.
10.2.3.2 Verification of resistance of insulating materials to normal heat			Meets the product standard's requirements.
10.2.3.3 Verification of resistance of insulating materials to abnormal heat and fire due to internal electric effects			Meets the product standard's requirements.
10.2.4 Resistance to ultra-violet (UV) radiation			Meets the product standard's requirements.
10.2.5 Lifting			Does not apply, since the entire switchgear needs to be evaluated.
10.2.6 Mechanical impact			Does not apply, since the entire switchgear needs to be evaluated.
10.2.7 Inscriptions			Meets the product standard's requirements.
10.3 Degree of protection of ASSEMBLIES			Does not apply, since the entire switchgear needs to be evaluated.

10.4 Clearances and creepage distances		Meets the product standard's requirements.
10.5 Protection against electric shock		Does not apply, since the entire switchgear needs to be evaluated.
10.6 Incorporation of switching devices and components		Does not apply, since the entire switchgear needs to be evaluated.
10.7 Internal electrical circuits and connections		Is the panel builder's responsibility.
10.8 Connections for external conductors		Is the panel builder's responsibility.
10.9 Insulation properties		
10.9.2 Power-frequency electric strength		Is the panel builder's responsibility.
10.9.3 Impulse withstand voltage		Is the panel builder's responsibility.
10.9.4 Testing of enclosures made of insulating material		Is the panel builder's responsibility.
10.10 Temperature rise		The panel builder is responsible for the temperature rise calculation. Eaton will provide heat dissipation data for the devices.
10.11 Short-circuit rating		Is the panel builder's responsibility. The specifications for the switchgear must be observed.
10.12 Electromagnetic compatibility		Is the panel builder's responsibility. The specifications for the switchgear must be observed.
10.13 Mechanical function		The device meets the requirements, provided the information in the instruction leaflet (IL) is observed.

Technical data ETIM 6.0

Low-voltage industrial components (EG000017) / Accessories for low-voltage switch technology (EC002498)

Electric engineering, automation, process control engineering / Low-voltage switch technology / Low-voltage switch technology (accessories) / Component for low-voltage switch technology (accessories) (ecl@ss8.1-27-37-92-01 [AKN570010])

Type of accessory

Connector

Approvals

North America Certification

UL/CSA certification not required

Dimensions

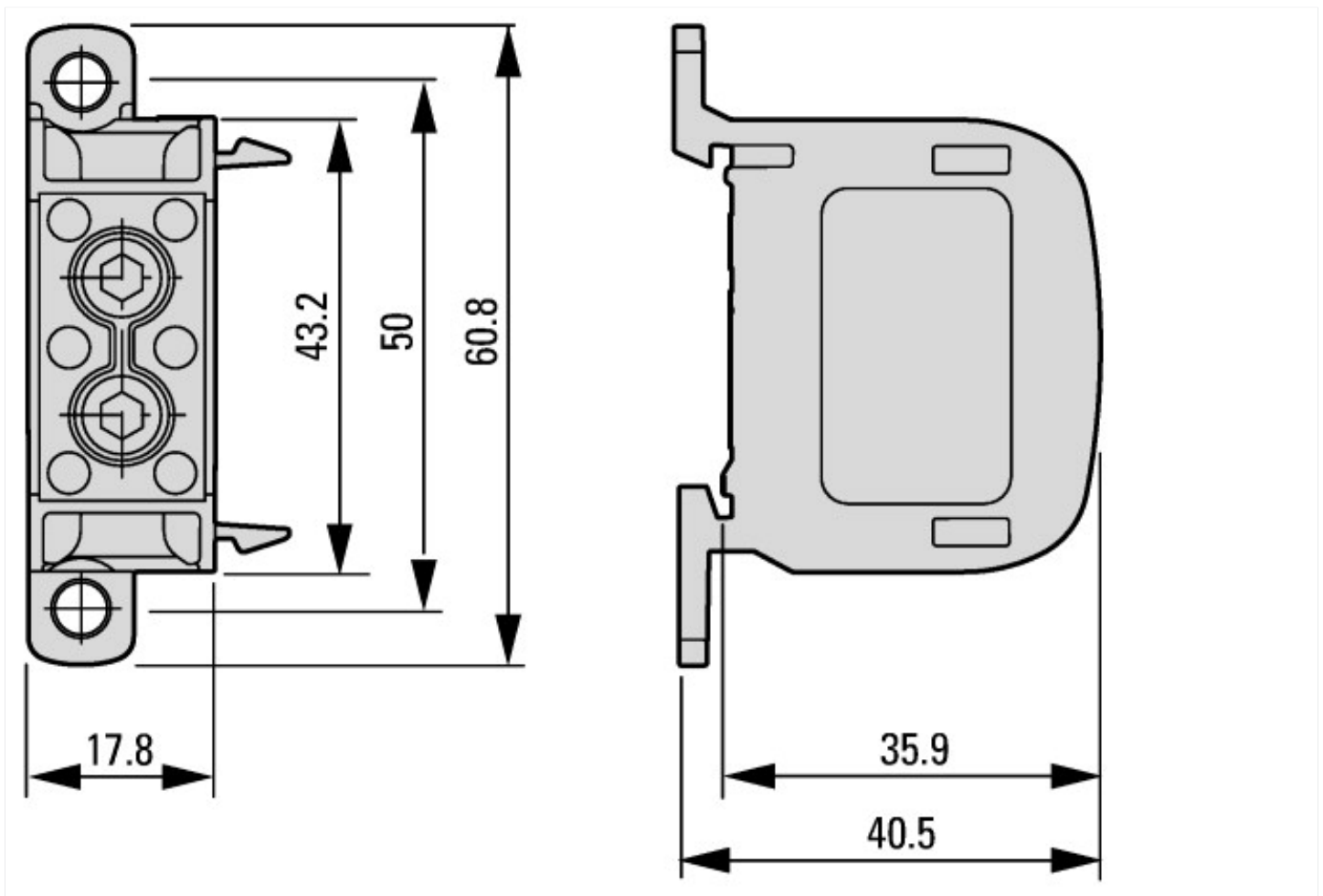

Additional product information (links)

Technical overview cam switch, switch-disconnector

<http://de.ecat.moeller.net/flip-cat/?edition=HPLTEv1&startpage=4.2>

System overview cam switch T	http://de.ecat.moeller.net/flip-cat?edition=HPLTEv1&startpage=4.4
System overview switch-disconnector P	http://de.ecat.moeller.net/flip-cat?edition=HPLTEv1&startpage=4.6
Key to part numbers Cam switch	http://de.ecat.moeller.net/flip-cat?edition=HPLTEv1&startpage=4.8
Key to part numbers Switch-disconnector	http://de.ecat.moeller.net/flip-cat?edition=HPLTEv1&startpage=4.8
Switches for ATEX	http://www.coopercrouse-hinds.eu/en/products/25-ex-safety-and-main-current-switches.html