



Timing relay, 1W, 0.05s-100h, multi-function, 24-240VAC 50/60Hz, 24-48VDC

Part no. ETR2-69
Article no. 262689
Catalog No. ETR2-69

Delivery program

Product range				ETR2 timing relays
Basic function				Timer relays
Function				Multi-functional On-delayed Off-delayed Fleeting contact on energization Fleeting contact on de-energization Flashing, pulse initiating Flashing, pause initiating Pulse forming
				Adjustable timing functions
Number of changeover contacts				1
Time range				0.05 s - 100 h
Time range				0.05 - 1 s 1.5 - 30 s 5 - 100 s 1.5 - 30 min 5 - 100 min 0.5 - 10 h 5 - 100 h
Rated operational current				
AC-15				
220 V 230 V 240 V	I_e	A		4
230 V (N/O)	I_e	A		3
230 V (NC)	I_e	A		3
Voltage range	U_{LN}	V		24 - 240 V AC, 50/60 Hz 24 - 48 V DC
Width		mm		17.5

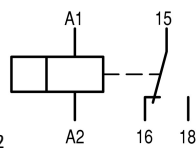

Terminal marking according to EN 50042

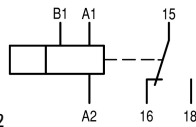

Terminal marking according to EN 50042

Technical data

Technical data in sheet catalogue

Other technical data (sheet catalogue)				Timing relays
--	--	--	--	---------------

Design verification as per IEC/EN 61439

Technical data for design verification				
Heat dissipation capacity	P_{diss}	W		0
Operating ambient temperature min.		°C		-25
Operating ambient temperature max.		°C		60
IEC/EN 61439 design verification				
10.2 Strength of materials and parts				
10.2.2 Corrosion resistance				
				Meets the product standard's requirements.

10.2.3.1 Verification of thermal stability of enclosures		Meets the product standard's requirements.
10.2.3.2 Verification of resistance of insulating materials to normal heat		Meets the product standard's requirements.
10.2.3.3 Verification of resistance of insulating materials to abnormal heat and fire due to internal electric effects		Meets the product standard's requirements.
10.2.4 Resistance to ultra-violet (UV) radiation		Meets the product standard's requirements.
10.2.5 Lifting		Does not apply, since the entire switchgear needs to be evaluated.
10.2.6 Mechanical impact		Does not apply, since the entire switchgear needs to be evaluated.
10.2.7 Inscriptions		Meets the product standard's requirements.
10.3 Degree of protection of ASSEMBLIES		Does not apply, since the entire switchgear needs to be evaluated.
10.4 Clearances and creepage distances		Meets the product standard's requirements.
10.5 Protection against electric shock		Does not apply, since the entire switchgear needs to be evaluated.
10.6 Incorporation of switching devices and components		Does not apply, since the entire switchgear needs to be evaluated.
10.7 Internal electrical circuits and connections		Is the panel builder's responsibility.
10.8 Connections for external conductors		Is the panel builder's responsibility.
10.9 Insulation properties		
10.9.2 Power-frequency electric strength		Is the panel builder's responsibility.
10.9.3 Impulse withstand voltage		Is the panel builder's responsibility.
10.9.4 Testing of enclosures made of insulating material		Is the panel builder's responsibility.
10.10 Temperature rise		The panel builder is responsible for the temperature rise calculation. Eaton will provide heat dissipation data for the devices.
10.11 Short-circuit rating		Is the panel builder's responsibility. The specifications for the switchgear must be observed.
10.12 Electromagnetic compatibility		Is the panel builder's responsibility. The specifications for the switchgear must be observed.
10.13 Mechanical function		The device meets the requirements, provided the information in the instruction leaflet (IL) is observed.

Technical data ETIM 6.0

Relays (EG000019) / Timer relay (EC001439)

Electric engineering, automation, process control engineering / Low-voltage switch technology / Relay and socket / Timed relay (ec@ss8.1-27-37-16-05 [AKF092010])

Type of electric connection		Screw connection
Function delay-on energization		Yes
Function delay on de-energization		Yes
Function floating contact on energization		Yes
Function floating contact on de-energization		Yes
Function star-delta		No
Function pulse shaping		Yes
Function flashing, starting with pause, fixed time		Yes
Function flashing, starting with pulse, fixed time		Yes
Clock function, starting with pause, variable		No
Clock function, starting with pulse, variable		No
With plug-in socket		No
Remote operation possible		No
Suitable only for remote control		No
Pluggable on auxiliary contact block		No
Rated control supply voltage U_s at AC 50HZ	V	24 - 240
Rated control supply voltage U_s at AC 60HZ	V	24 - 240
Rated control supply voltage U_s at DC	V	24 - 240
Voltage type for actuating		AC/DC
Time range	s	0.05 - 360000
Number of outputs, undelayed, normally closed contact		0
Number of outputs, undelayed, normally open contact		0
Number of outputs, undelayed, change-over contact		0
Number of outputs, delayed, normally closed contact		0
Number of outputs, delayed, normally open contact		0
Number of outputs, delayed, change-over contact		1
Outputs, reversible delayed/undelayed		Yes

With semiconductor output		No
Width	mm	18
Height	mm	70
Depth	mm	63

Approvals

Product Standards		IEC/EN 61812-1; IEC/EN 60947-5-1; UL 508; CSA-22.2 No. 14; CE marking
UL File No.		E29184
UL Category Control No.		NKCR, NKCR7
CSA File No.		UL report valid
CSA Class No.		3211-03
North America Certification		UL listed, certified by UL for use in Canada
Degree of Protection		IEC: IP20, UL/CSA Type: -

Characteristics

Flow diagram for timing functions

LED legend

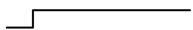

Time not running, contact 15 – 18 closed

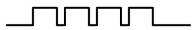

Time running, contact 15 – 18 closed

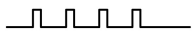

Time running, contact 15 – 18 not closed

① A2/A1 linked

② A2/A1 not linked

11 On-delayed

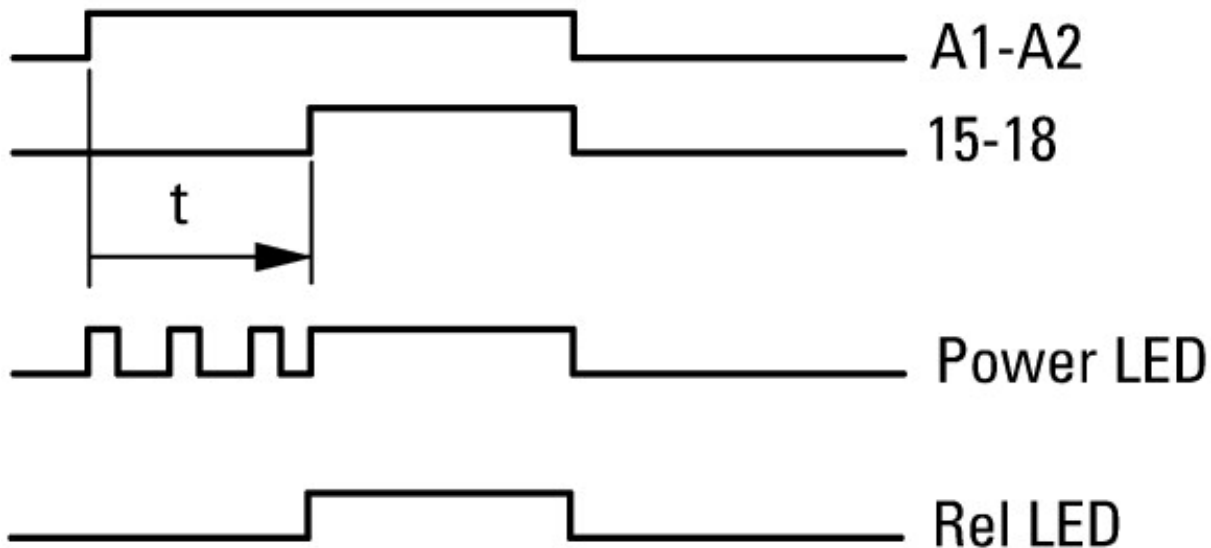

21 Fleeting contact on energization

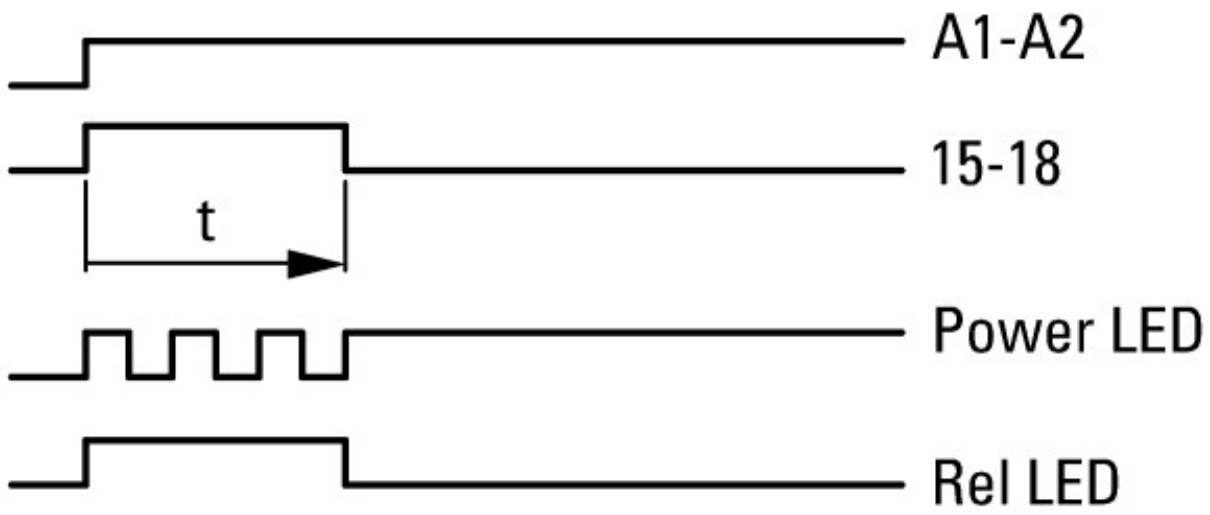

42 Flashing, pulse initiating

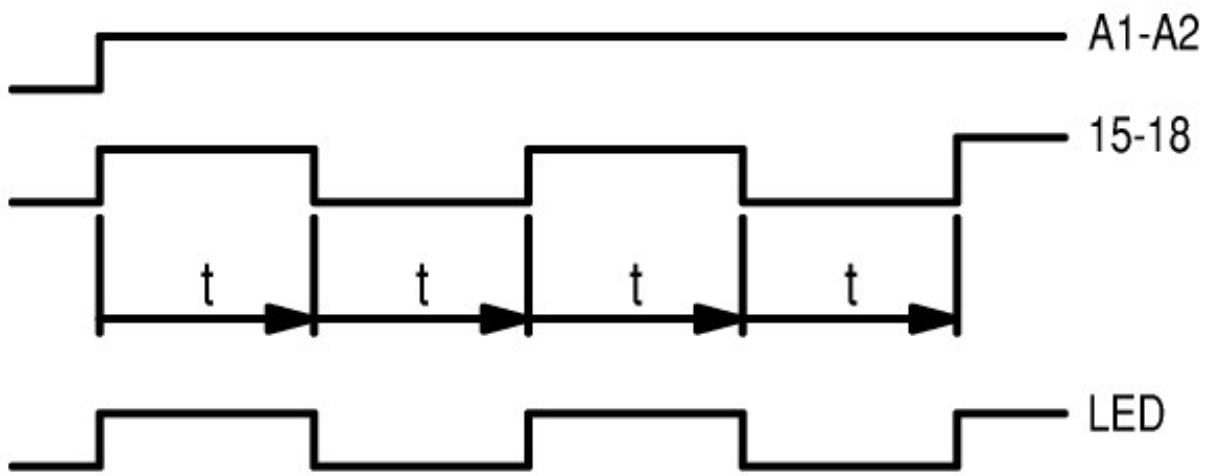

43 Flashing, pause initiating

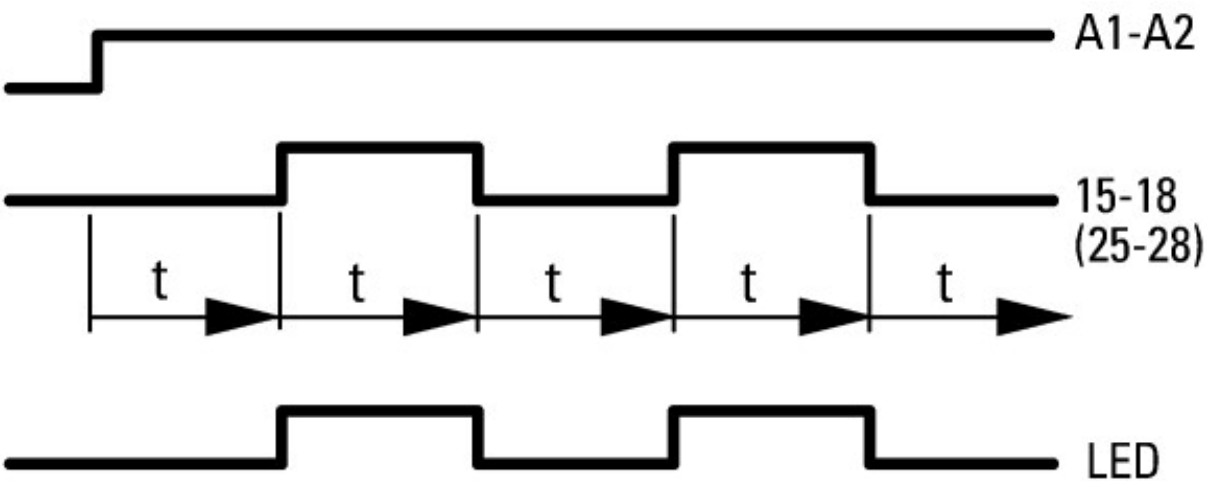

Dimensions

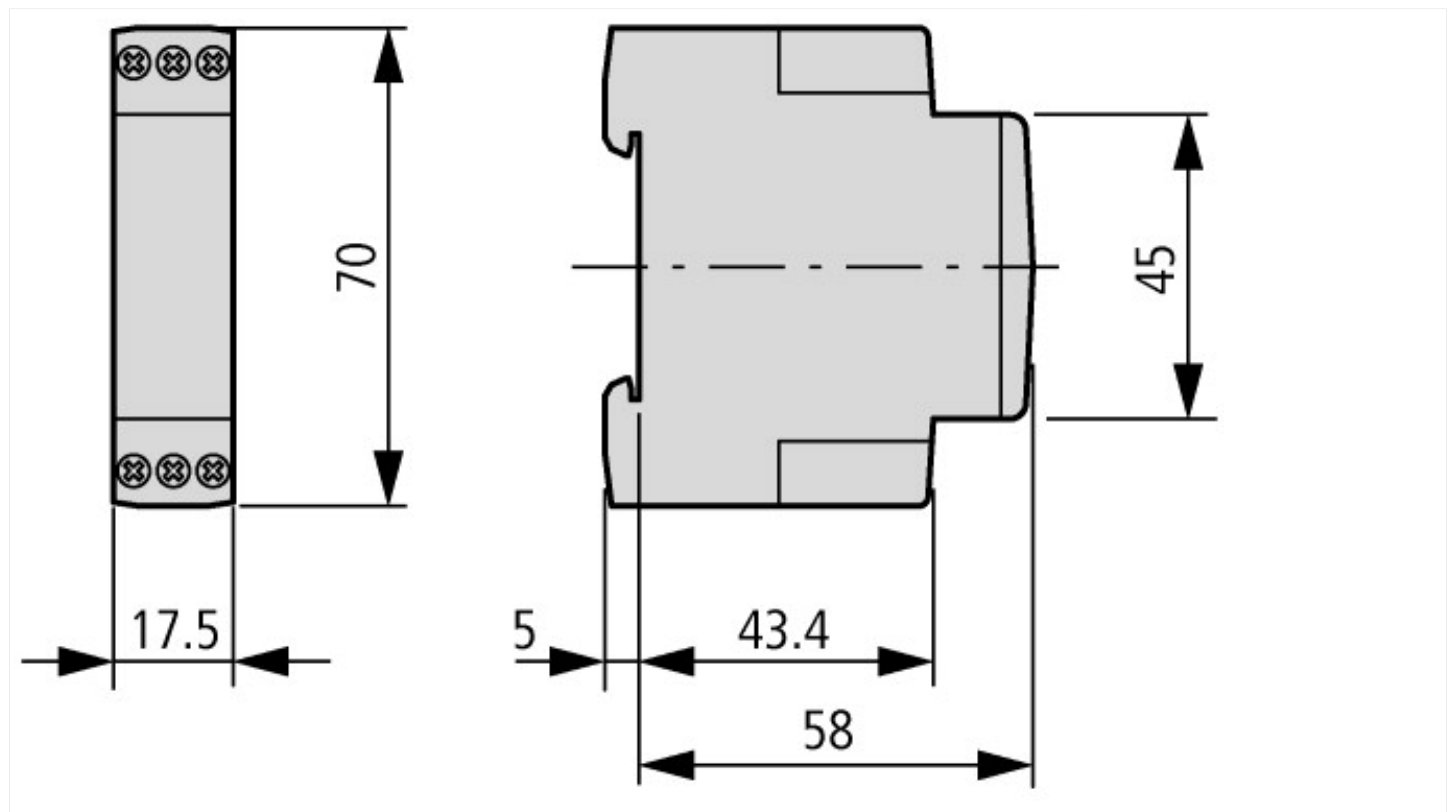

Additional product information (links)

IL04910005Z (AWA2527-2372) Solid-state timing relay

IL04910005Z (AWA2527-2372) Solid-state timing relay ftp://ftp.moeller.net/DOCUMENTATION/AWA_INSTRUCTIONS/IL04910005Z2016_02.pdf

Terminal marking	http://ecat.moeller.net/flip-cat/?edition=HPLEN&startpage=11.7
Timing functions	http://ecat.moeller.net/flip-cat/?edition=HPLEN&startpage=11.8
Load limit curves	http://ecat.moeller.net/flip-cat/?edition=HPLEN&startpage=11.10
Timing relays	http://ecat.moeller.net/flip-cat/?edition=HPLEN&startpage=11.13