



Safety relay, 24 V DC, 14DI, 4DO-Trans, 1DO relay, display, easyNet

Part no. **ES4P-221-DMXX1**
Article no. **111016**

Delivery program

Product range			Control relays for safety applications
Basic function			easy800 with safety function blocks
Features			
Safety functions			Stopping in the event of an emergency Protective door OSSD input ESPE with muting function Two-hand control Highest speed monitoring Zero speed monitoring Safety timing relay Mode selection Enabling switch Feedback circuit
Display & keypad			-
Mounting width		mm	107.5
Technical safety parameters:			
Values according to EN ISO 13849-1			
Performance level	according to EN ISO 13849-1		PL e
Category	according to EN ISO 13849-1		Kat. 4
Safety integrity level claim limit	in accordance with 62061		SILCL 3
Probability of failure per hour	PFH _d	x 10 ⁻¹⁰	23
Safety integrity level	In accordance with IEC 61508		SIL 3
Real time clock			✓
Supply voltage	U _s		24 V DC
Networking			easyNet/easyLink
Safety/standard circuit diagram			✓/✓
Instructions			
Expandable: standard inputs/outputs and standard bus systems			
individual laser inscription with ES4-COMBINATION possible →#2011790			
Inputs (safety)			14
Outputs (safety)			
6 A relay			1 (redundant)
Transistor			4
Test signal			4

Technical data

General			
Standards			EN ISO 13849-1 EN 50156-1 EN 50178 EN 50581_x EN 61000-6-2 EN 61000-6-3 IEC 61508 IEC 62061
Dimensions (W x H x D)		mm	107.5 (6 TE) x 90 x 72
Weight		kg	0.35
Mounting			Top-hat rail IEC/EN 60715, 35 mm or screw fixing using fixing brackets ZB4-101-GF1 (accessories)

Times

Inputs			
Max. duration of external test pulse		ms	1
Semi-conductor output			
Off test pulse		ms	< 1
Off-delay		ms	< 1

Terminal capacities

Solid		mm ²	0.2/4 (AWG 22 - 12)
Flexible with ferrule		mm ²	0.2/2.5 (AWG 22 - 12)
Standard screwdriver		mm	3.5 x 0.8
Max. tightening torque		Nm	0.6

Climatic environmental conditions

Operating ambient temperature		°C	-25 to + 55 cold as per IEC 60068-2-1 heat as per IEC 60068-2-2 Damp heat – constant to IEC 60068-2-78 – cyclical to IEC 60068-2-30
Condensation			Take appropriate measures to prevent condensation
Ambient temperature			
Storage	θ	°C	-40 - +70
relative humidity		%	5 - 95 in accordance with IEC 60068-2-30, IEC 60068-2-78 Non-condensing
Air pressure (operation)		hPa	795 - 1080

Ambient conditions, mechanical

Degree of protection			IP20 (IEC/EN 60529, EN50178, VBG 4)
Constant amplitude 0.15 mm			
constant amplitude		Hz	10 - 57 (0.15 mm)
constant acceleration		Hz	57 - 150 (2g)
Vibrations	3,5 mm / 1 g	Hz	In accordance with IEC 60068-2-6
Mechanical shock resistance		g	18 shocks Sinusoidal 15 g/11 ms according to IEC 60068-2-27
Drop to	Drop height	mm	50 (IEC/EN 60068-2-31)
Free fall, packaged		m	0,3 (IEC/EN 61131-2)

Electromagnetic compatibility (EMC)

Electromagnetic compatibility			As per IEC 62061, increased EMC requirements for safety-relevant functions
Overvoltage category/pollution degree			III/2
Electrostatic discharge (ESD)			
applied standard			according to IEC EN 61000-4-2
Air discharge		kV	15
Contact discharge		kV	8
Electromagnetic fields (RFI)		V/m	30 to IEC EN 61000-4-3
Radio interference suppression			EN 55011 Class B, EN 55022 Class B
Burst		kV	according to IEC/EN 61000-4-4 Supply cables: 4 Signal cables: 4
power pulses (Surge)			2 kV (supply cables, symmetrical) 4 kV (semi-conductor outputs, symmetrical) In accordance with IEC 62061
Immunity to line-conducted interference		V	20, in accordance with IEC/EN 61000-4-6

Insulation resistance

Clearance in air and creepage distances			EN 50178, UL 508, CSA C22.2, No. 142, EN 60664-1:2003
Insulation resistance			EN 50178

Back-up of real-time clock

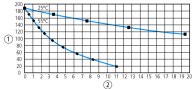
Back-up of real-time clock			
			<p>① Backup time (hours) with fully charged double layer capacitor</p> <p>② Service life (years)</p>

Accuracy of the real-time clock		s/day	Normally ± 2 (± 0.5 h/year), may vary up to ± 5 s/day depending on the ambient temperature
---------------------------------	--	-------	---

Accuracy

Resolution			
Range "S"		ms	50
Range "M:S"		s	1
Range "H:M"		min	1

Repetition accuracy

Resolution			
Range "S"		ms	50
Range "M:S"		s	1
Range "H:M"		min	1

Retentive memory

Read/write cycles (minimum)			10000000000000 (10^{14})
-----------------------------	--	--	------------------------------

Power supply

Rated operational voltage	U_e	V	24 DC (-15/+20%)
Permissible range	U_e		20.4 - 28.8 V DC
Residual ripple		%	≤ 5
Input current			
Input current 115/230 V AC		mA	< 250
Voltage dips		ms	≤ 10 (IEC/EN 61131-2)
Heat dissipation		W	< 6
Potential isolation			From the inputs: yes: no from the outputs: yes to PC interface: no to easyLink: no to easyNet: yes

Network easyNet

Stations		Number	max. 8
Data transfer rate/distance			1000 kBit/s, 6 m 500 kBit/s, 25 m 250 kBit/s, 40 m 125 kBit/s, 125 m 50 kBit/s, 300 m 20 kBit/s, 700 m 10 kBit/s, 1000 m
Potential isolation			
Potential isolation between inputs and internal power supply			yes
Potential isolation			from power supply: yes From the inputs: yes from the outputs: yes to PC interface: yes to memory card: yes to easyLink: no to easyNet: yes
Bus termination			yes (first and last station)
Connection technique			RJ45, 8-pole

Digital inputs 24 V DC

Number			14
Potential isolation			from power supply: no between digital inputs: no from the outputs: yes to the interface: no to the memory card: no to easyLink: no to easyNet: yes
Rated signal voltage	U_e	V DC	24
On 0 signal	U_e	V DC	< 5
On 1 signal	U_e	V DC	> 15,0
Input current on 1 signal			
IS1 - IS14		mA	5.7 (at 24 V DC)
Hardware delay time from 0 to 1		ms	Debounce ON: 24 Debounce OFF: 0.06 (IS1, IS2), 0.17 (IS3 to IS14)
Hardware delay time from 1 to 0		ms	

			Debounce ON: 24 Debounce OFF: 0.08 (IS1, IS2), 0.22 (IS3 to IS14)
Cable length (unscreened)		m	100
Single cable length of test signal output to the device input (shielded)		m	1000
Total of single cable lengths from one test signal output to the device inputs (shielded)		m	3000
Maximum rotary frequency at device inputs IS1 and IS2, when using function block OM or ZM		Hz	1000
Maximum switching frequency at input (does not apply to I1, I2, if function block SM or OM is used)		Operations/h	300

Test signal outputs

Number			4 (T1 to T4)
Voltage		V DC	24
Potential isolation			No

Relay outputs

			1 (redundant)
Outputs in groups of			1
Parallel switching of outputs for increased output			Not permissible
Safety level			3 redundant relay outputs, 6 months test interval According to EN 50156
Protection of an output relay			Fuse: 6 A gL/gG, Circuit-breaker with C characteristic: 4 A (only permissible with 24V DC), Short-circuit current $I_K < 250$ A
Potential isolation			from power supply: yes From the inputs: yes between digital inputs: yes to the interface: yes to easyNet: yes to easyLink: yes Safe isolation according to EN 50178: 300 V AC Basic isolation: 600 V AC
Lifespan, mechanical	Operations	$\times 10^6$	10
Contacts			
Conventional thermal current	I_{th}	A	6
Rated impulse withstand voltage U_{imp} of contact coil		kV	6
Rated operational voltage	U_e	V AC	250
Rated insulation voltage	U_i	V AC	250
safe isolation between coil and contact		V AC	300 in accordance with 50178
Switching capacity			DC-13, 24 V DC, 0.1 Hz: 40000 operations (in accordance with IEC 60947-5-1) AC-15, 230 V AC, 3 A: 80000 operations (in accordance with IEC 60947-5-1) DC: B300 (in accordance with UL 508) AC: R300 (in accordance with UL 508)
Switching frequency			
Mechanical operations		$\times 10^6$	10
Switching frequency		Hz	15

Transistor outputs

Number			4
Rated operational voltage	U_e	V DC	24
Permissible range	U_e		20.4 - 28.8 V DC
Residual ripple		%	5
Supply current			
On 0 signal	Normally/max. mA		30/50
On 1 signal	Normally/max. mA		60/100
Protection against polarity reversal			Yes
Potential isolation			from power supply: yes From the inputs: yes between digital inputs: no to the interface: yes to easyLink: yes to easyNet: yes to the memory card: yes
Rated operational current at signal „1“ DC per channel	I_e	A	Max. 0.5
Lamp load without R_V per channel		W	5
Max. output voltage			

On 0 signal with external load < 10 MΩ	V	$\leq 2,4$
On 1 signal with $I_e = 0.5$ A	V	$U = U_e - 1$ V
Short-circuit protection		Yes
Short-circuit tripping current for $R_a \leq 10$ mΩ	A	$0.7 \leq I_e \leq 2$ per output
Total short-circuit current	A	8
Peak short-circuit current	A	16
Thermal cutout		Yes
Back-up fuse	A	≤ 8
max. load capacity	μF	0.6
Max. Cable length (unscreened)	m	50
Max. operating frequency with constant resistive load	Operation h	33500 ($R_L < 100$ kΩ, abhängig von Programm und Belastung)
Parallel switching of outputs for increased output		Not permissible
Inductive load to EN 60947-5-1		
Without external suppressor circuit		
Duty factor		$T_{0.95} \approx 3 \times T_{0.65} = 3 \times L/R$. $T_{0.95}$ = Time in ms, until 95 % of the steady-state current has been reached.
With external suppressor circuit		
Utilization factor	g	1
Duty factor	% DF	100
Max. switching frequency, max. duty factor = 50%	f	Hz 0.5

Design verification as per IEC/EN 61439

Technical data for design verification			
Rated operational current for specified heat dissipation	I_n	A	0
Heat dissipation per pole, current-dependent	P_{vid}	W	0
Equipment heat dissipation, current-dependent	P_{vid}	W	0
Static heat dissipation, non-current-dependent	P_{vs}	W	6
Heat dissipation capacity	P_{diss}	W	0
Operating ambient temperature min.		°C	-25
Operating ambient temperature max.		°C	55
IEC/EN 61439 design verification			
10.2 Strength of materials and parts			
10.2.2 Corrosion resistance			Meets the product standard's requirements.
10.2.3.1 Verification of thermal stability of enclosures			Meets the product standard's requirements.
10.2.3.2 Verification of resistance of insulating materials to normal heat			Meets the product standard's requirements.
10.2.3.3 Verification of resistance of insulating materials to abnormal heat and fire due to internal electric effects			Meets the product standard's requirements.
10.2.4 Resistance to ultra-violet (UV) radiation			Meets the product standard's requirements.
10.2.5 Lifting			Does not apply, since the entire switchgear needs to be evaluated.
10.2.6 Mechanical impact			Does not apply, since the entire switchgear needs to be evaluated.
10.2.7 Inscriptions			Meets the product standard's requirements.
10.3 Degree of protection of ASSEMBLIES			Meets the product standard's requirements.
10.4 Clearances and creepage distances			Meets the product standard's requirements.
10.5 Protection against electric shock			Does not apply, since the entire switchgear needs to be evaluated.
10.6 Incorporation of switching devices and components			Does not apply, since the entire switchgear needs to be evaluated.
10.7 Internal electrical circuits and connections			Is the panel builder's responsibility.
10.8 Connections for external conductors			Is the panel builder's responsibility.
10.9 Insulation properties			
10.9.2 Power-frequency electric strength			Is the panel builder's responsibility.
10.9.3 Impulse withstand voltage			Is the panel builder's responsibility.
10.9.4 Testing of enclosures made of insulating material			Is the panel builder's responsibility.
10.10 Temperature rise			The panel builder is responsible for the temperature rise calculation. Eaton will provide heat dissipation data for the devices.
10.11 Short-circuit rating			Is the panel builder's responsibility.

10.12 Electromagnetic compatibility		Is the panel builder's responsibility.
10.13 Mechanical function		The device meets the requirements, provided the information in the instruction leaflet (IL) is observed.

Technical data ETIM 6.0

PLC's (EG000024) / Logic module (EC001417)

Electric engineering, automation, process control engineering / Control / Programmable logic control (SPS) / Logic module (ecl@ss8.1-27-24-22-16 [AKE539011])

Supply voltage AC 50 Hz	V	0 - 0
Supply voltage AC 60 Hz	V	0 - 0
Supply voltage DC	V	20.4 - 28.8
Voltage type of supply voltage		DC
Switching current	A	8
Number of analogue inputs		0
Number of analogue outputs		4
Number of digital inputs		14
Number of digital outputs		5
With relay output		Yes
Number of HW-interfaces industrial Ethernet		0
Number of HW-interfaces PROFINET		0
Number of HW-interfaces RS-232		1
Number of HW-interfaces RS-422		0
Number of HW-interfaces RS-485		0
Number of HW-interfaces serial TTY		0
Number of HW-interfaces USB		0
Number of HW-interfaces parallel		0
Number of HW-interfaces Wireless		0
Number of HW-interfaces other		3
With optical interface		No
Supporting protocol for TCP/IP		No
Supporting protocol for PROFIBUS		No
Supporting protocol for CAN		No
Supporting protocol for INTERBUS		No
Supporting protocol for ASI		No
Supporting protocol for KNX		No
Supporting protocol for MODBUS		No
Supporting protocol for Data-Highway		No
Supporting protocol for DeviceNet		No
Supporting protocol for SUCONET		No
Supporting protocol for LON		No
Supporting protocol for PROFINET IO		No
Supporting protocol for PROFINET CBA		No
Supporting protocol for SERCOS		No
Supporting protocol for Foundation Fieldbus		No
Supporting protocol for EtherNet/IP		No
Supporting protocol for AS-Interface Safety at Work		No
Supporting protocol for DeviceNet Safety		No
Supporting protocol for INTERBUS-Safety		No
Supporting protocol for PROFIsafe		No
Supporting protocol for SafetyBUS p		No
Supporting protocol for other bus systems		Yes
Radio standard Bluetooth		No
Radio standard WLAN 802.11		No
Radio standard GPRS		No
Radio standard GSM		No
Radio standard UMTS		No
IO link master		No

Redundancy			Yes
With display			No
Degree of protection (IP)			IP20
Basic device			Yes
Expandable			Yes
Expansion device			No
With timer			Yes
Rail mounting possible			Yes
Wall mounting/direct mounting			Yes
Front build in possible			No
Rack-assembly possible			No
Suitable for safety functions			Yes
Category according to EN 954-1			4
SIL according to IEC 61508			3
Performance level acc. to EN ISO 13849-1			Level e
Appendant operation agent (Ex ia)			No
Appendant operation agent (Ex ib)			No
Explosion safety category for gas			None
Explosion safety category for dust			None
Width		mm	107.5
Height		mm	90
Depth		mm	72

Approvals

Product Standards			IEC/EN see Technical Data; UL 508; CSA-C22.20.4-04; CSA-22.2 No. 142-MI1987; CE marking
UL File No.			CSA report applies to both US and Canada
UL Category Control No.			NRAQ
CSA File No.			012528
CSA Class No.			2252-81; 2252-01
North America Certification			CSA certified, certified by CSA for use in the US
Degree of Protection			IEC: IP20, UL/CSA Type: -

Characteristics

PU05907001Z safety manual

Dimensions

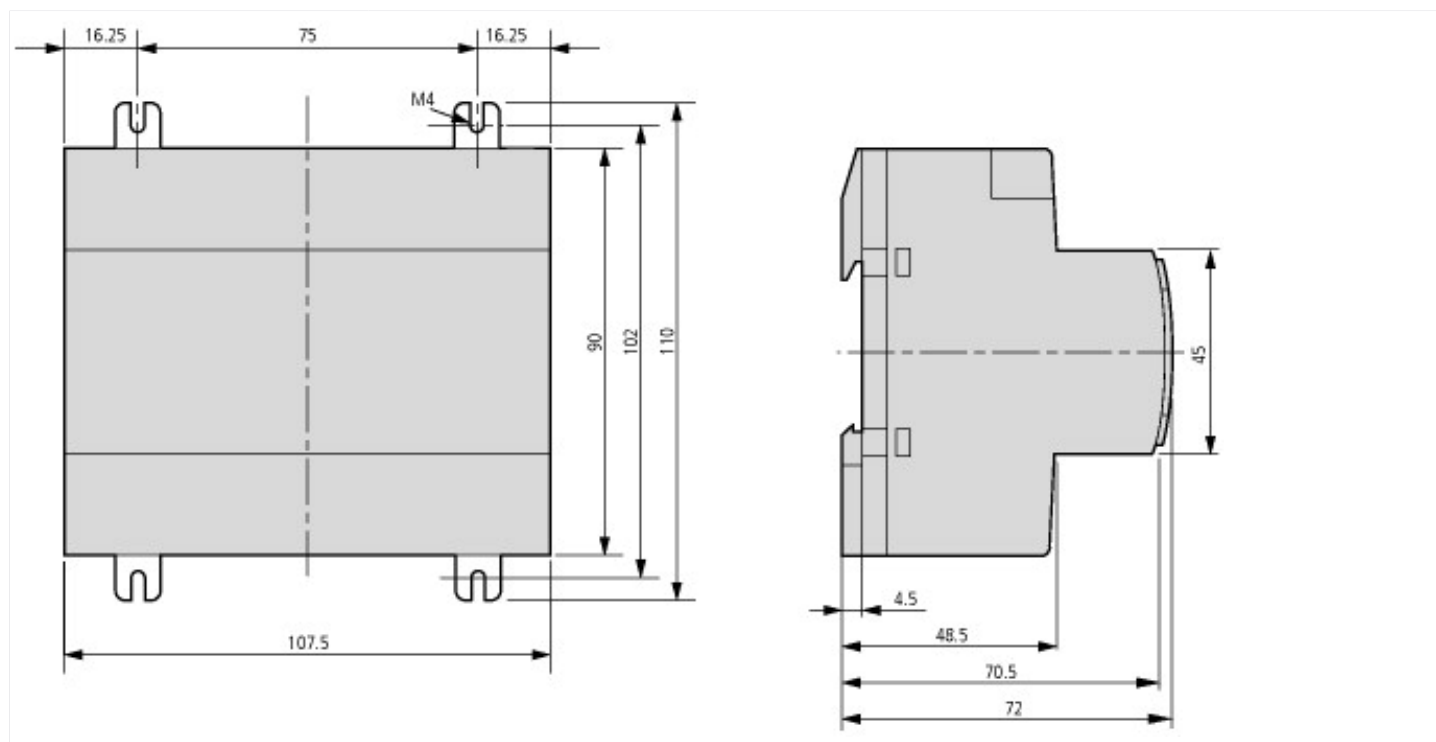

Additional product information (links)

Instruction leaflet "easySafety ES4P safety relays" IL05013002Z-EN

Instruction leaflet "easySafety ES4P safety relays" IL05013002Z-EN	ftp://ftp.moeller.net/DOCUMENTATION/AWA_INSTRUCTIONS/IL05013002Z.pdf
Instruction leaflet "easySafety ES4P safety relays" IL05013002Z-EN	ftp://ftp.moeller.net/DOCUMENTATION/AWA_INSTRUCTIONS/IL05013002Z2015_12.pdf
Instruction leaflet "easySafety ES4P safety relays" IL05013002Z-EN	ftp://ftp.moeller.net/DOCUMENTATION/AWA_INSTRUCTIONS/IL05013002Z2016_02.pdf

Manual "easySafety ES4P control relays suitable for safety applications" MN05013001Z

MN05013001Z Handbuch Sicherheitsgerichtetes Steuerrelais easySafety ES4P - Deutsch	ftp://ftp.moeller.net/DOCUMENTATION/AWB_MANUALS/MN05013001Z_DE.pdf
MN05013001Z Manual easySafety ES4P control relay suitable for safety applications - English	ftp://ftp.moeller.net/DOCUMENTATION/AWB_MANUALS/MN05013001Z_EN.pdf
MN05013001Z Manuel Module logique de sécurité easySafety ES4P - français	ftp://ftp.moeller.net/DOCUMENTATION/AWB_MANUALS/MN05013001Z_FR.pdf
MN05013001Z Manuale relè di comando relativo alla sicurezza easySafety ES4P - italiano	ftp://ftp.moeller.net/DOCUMENTATION/AWB_MANUALS/MN05013001Z_IT.pdf
Download easySoft-Safety	http://downloadcenter.moeller.net/de/software.1d4beb75-d41e-442a-b59c-a19bfdae66af
Labeleditor (Beschriftungssoftware)	http://downloadcenter.moeller.net/de/software.f6023a63-5acb-42c7-a51c-ccf99091cace