



Switched-mode power supply unit, 100-240VAC/24VDC, 1.25A, 1-phase, controlled

Part no. EASY430-POW
Article no. 110940

Delivery program

Product range			Control relays easyRelay Multi-function-display MFD-Titan
Product range			Switched-mode power supply units easyPOW
Description			primary chopper controlled
Phases			Single-phase
Input voltage range			85 - 264 V AC
Nominal input voltage			100 - 240 V AC
Rated output voltage			24 V DC (± 3%)
Rated output current		A	1.25
For use with			easy500 easy700 easy800 MFD-CP8 EC4P ES4P
Description			<ul style="list-style-type: none"> Rated input voltage: 50/60 HZ: 115/230 V AC Rated output voltage (residual ripple): 24 V DC (± 3 %) Rated output current: 1.25 A

Technical data

General

Standards			EN 55011, EN 55022, IEC/EN 61000-4, IEC 60068-2-6, IEC 60068-2-27
Dimensions (W x H x D)		mm	71.5 (4 PE) x 90 x 58
Weight		kg	0.25
Mounting			Top-hat rail IEC/EN 60715, 35 mm or screw fixing using fixing brackets ZB4-101-GF1 (accessories)

Terminal capacities

Solid		mm ²	0.2/4 (AWG 22 - 12)
Flexible with ferrule		mm ²	0.2/2.5 (AWG 22 - 12)
Standard screwdriver		mm	3.5 x 0.8
Max. tightening torque		Nm	0.6

Climatic environmental conditions

Operating ambient temperature		°C	-25 to 55, cold as per IEC 60068-2-1, heat as per IEC 60068-2-2
Condensation			Take appropriate measures to prevent condensation
Storage		°C	- 40 - 70
Relative humidity, non-condensing (IEC/EN 60068-2-30)		%	
Air humidity, non-condensing, min.		%	5
Air humidity, non-condensing, max.		%	95
Air pressure (operation)		hPa	795 - 1080
Max. installation altitude above sea level, observe derating with higher altitudes		m	2000

Ambient conditions, mechanical

Protection type (IEC/EN 60529, EN50178, VBG 4)			IP20
Vibrations (IEC/EN 60068-2-6)		Hz	
Constant amplitude 0.15 mm		Hz	10 - 57
Constant acceleration 2 g		Hz	57 - 150
Mechanical shock resistance (IEC/EN 60068-2-27) semi-sinusoidal 15 g/11 ms		Impacts	18
Drop to IEC/EN 60068-2-31	Drop height	mm	50
Free fall, packaged (IEC/EN 60068-2-32)		m	1
Mounting position			Vertical or horizontal

Electromagnetic compatibility (EMC)

Electrostatic discharge (IEC/EN 61000-4-2, Level 3, ESD)		kV	
Air discharge		kV	8
Contact discharge		kV	6
Electromagnetic fields (RFI) to IEC EN 61000-4-3		V/m	10
Radio interference suppression			EN 55011 Class B, EN 55022 Class B
Burst pulses (IEC/EN 61000-4-4, level 3)		kV	2
Power pulses (surge) (IEC/EN 61000-4-5)		kV	2 (supply cables, symmetrical)
High-energy pulses (surge) (IEC/EN 61000-4-5, level 2), 24 V		kV	0.5 (outgoer cables symmetrical, EASY...DC)
Immunity to line-conducted interference to (IEC/EN 61000-4-6)		V	10
Surge voltage (EN 50178), 24 V		kV	6

Insulation resistance

Clearance in air and creepage distances			EN 50178
Insulation resistance			EN 50178
Protection class U_{out} to U_{in}			Class II to IEC 60536
Potential isolation primary/secondary			Yes, SELV (VDE 0100 Part 410; IEC 60364-4-41, HD 384.4.41 S2) EN 60950, EN 50178

Input voltage

Rated input voltage DC		V	100/120/230/240 (-15/+10 %)
Protective switches AC			FAZ-C2/1 or FAZ-B6/1
Rated input voltage DC		V DC	85 264
DC protective switches			FAZ-C2/1-DC
Voltage range		V AC	85 - 264
Frequency range		Hz	47 - 63
Mains failure bridging 115/230 V (IEC/EN 61000-4-11)		ms	> 20/> 40
Fuse 115/230 V		A	2/1 slow

Rating data

Efficiency		%	> 83
Power consumption		W	Normally 35
Power loss	P	W	Normally 5

Input current

Input current nominal 115/240 V		A	Approx. 0.6/0.3
Inrush current at 25 °C 230 V		A	< 18

Output voltage

24 V DC			
Rated value		V DC	24
Tolerance		%	± 3
Switching peaks 115/230		mV _{pp}	< 5
Effect of input voltage		%	± 1
Effect with 25 - 100 % load change		%	± 2
Can be connected in parallel to increase power			Yes

Output current

24 V DC			
Output current		A	0 - 1.25
Effectiveness of current limitation		A	> 1.5
Reduction of output voltage after current limitation		V	< 18
Overload proof			Yes, by current limitation
Proof against sustained short circuit			Yes, hiccup mode, approx. 2 Hz

Special load conditions

Lamp load, cold, 24 V DC		W	10
Base load present		W	5
Behaviour on emergency-stop in 24 V circuit, disconnection with contactor (contactor load, no damage)		W	30

Displays

Indication of output voltage (LED, continuous green light = OK)		V DC	24
---	--	------	----

Design verification as per IEC/EN 61439

Technical data for design verification			
--	--	--	--

Rated operational current for specified heat dissipation	I_n	A	0
Heat dissipation per pole, current-dependent	P_{vid}	W	0
Equipment heat dissipation, current-dependent	P_{vid}	W	0
Static heat dissipation, non-current-dependent	P_{vs}	W	5
Heat dissipation capacity	P_{diss}	W	0
Operating ambient temperature min.		°C	-25
Operating ambient temperature max.		°C	55
IEC/EN 61439 design verification			
10.2 Strength of materials and parts			
10.2.2 Corrosion resistance			Meets the product standard's requirements.
10.2.3.1 Verification of thermal stability of enclosures			Meets the product standard's requirements.
10.2.3.2 Verification of resistance of insulating materials to normal heat			Meets the product standard's requirements.
10.2.3.3 Verification of resistance of insulating materials to abnormal heat and fire due to internal electric effects			Meets the product standard's requirements.
10.2.4 Resistance to ultra-violet (UV) radiation			Meets the product standard's requirements.
10.2.5 Lifting			Does not apply, since the entire switchgear needs to be evaluated.
10.2.6 Mechanical impact			Does not apply, since the entire switchgear needs to be evaluated.
10.2.7 Inscriptions			Meets the product standard's requirements.
10.3 Degree of protection of ASSEMBLIES			Meets the product standard's requirements.
10.4 Clearances and creepage distances			Meets the product standard's requirements.
10.5 Protection against electric shock			Does not apply, since the entire switchgear needs to be evaluated.
10.6 Incorporation of switching devices and components			Does not apply, since the entire switchgear needs to be evaluated.
10.7 Internal electrical circuits and connections			Is the panel builder's responsibility.
10.8 Connections for external conductors			Is the panel builder's responsibility.
10.9 Insulation properties			
10.9.2 Power-frequency electric strength			Is the panel builder's responsibility.
10.9.3 Impulse withstand voltage			Is the panel builder's responsibility.
10.9.4 Testing of enclosures made of insulating material			Is the panel builder's responsibility.
10.10 Temperature rise			The panel builder is responsible for the temperature rise calculation. Eaton will provide heat dissipation data for the devices.
10.11 Short-circuit rating			Is the panel builder's responsibility.
10.12 Electromagnetic compatibility			Is the panel builder's responsibility.
10.13 Mechanical function			The device meets the requirements, provided the information in the instruction leaflet (IL) is observed.

Technical data ETIM 6.0

PLC's (EG000024) / PLC system power supply (EC000599)		
Electric engineering, automation, process control engineering / Control / Programmable logic control (SPS) / SPS system power supply (ecl@ss8.1-27-24-22-09 [AKE532011])		
Input voltage at AC 50 Hz	V	85 - 264
Input voltage at AC 60 Hz	V	85 - 264
Input voltage at DC	V	0 - 0
Type of voltage (input voltage)		AC
Max. input current AC 50 Hz	A	0
Max. input current AC 60 Hz	A	0
Max. input current DC	A	0
Type of output voltage		DC
Output voltage at AC 50 Hz	V	0 - 0
Output voltage at AC 60 Hz	V	0 - 0
Output voltage at DC	V	0 - 0
Max. output current AC 50 Hz	A	0
Max. output current AC 60 Hz	A	0
Max. output current DC	A	1.25
Redundancy		No
Suitable for safety functions		No
Width	mm	72
Height	mm	90

Depth	mm	60
-------	----	----

Approvals

Product Standards	IEC/EN see Technical Data; UL 508; CSA C22.2 No. 107.1-01; CE marking
UL File No.	E300415
UL Category Control No.	NMTR, NMTR7
CSA File No.	UL report applies to both US and Canada
CSA Class No.	3211-87, 3211-07
North America Certification	UL listed, certified by UL for use in Canada
Degree of Protection	IEC: IP20, UL/CSA Type: -

Dimensions

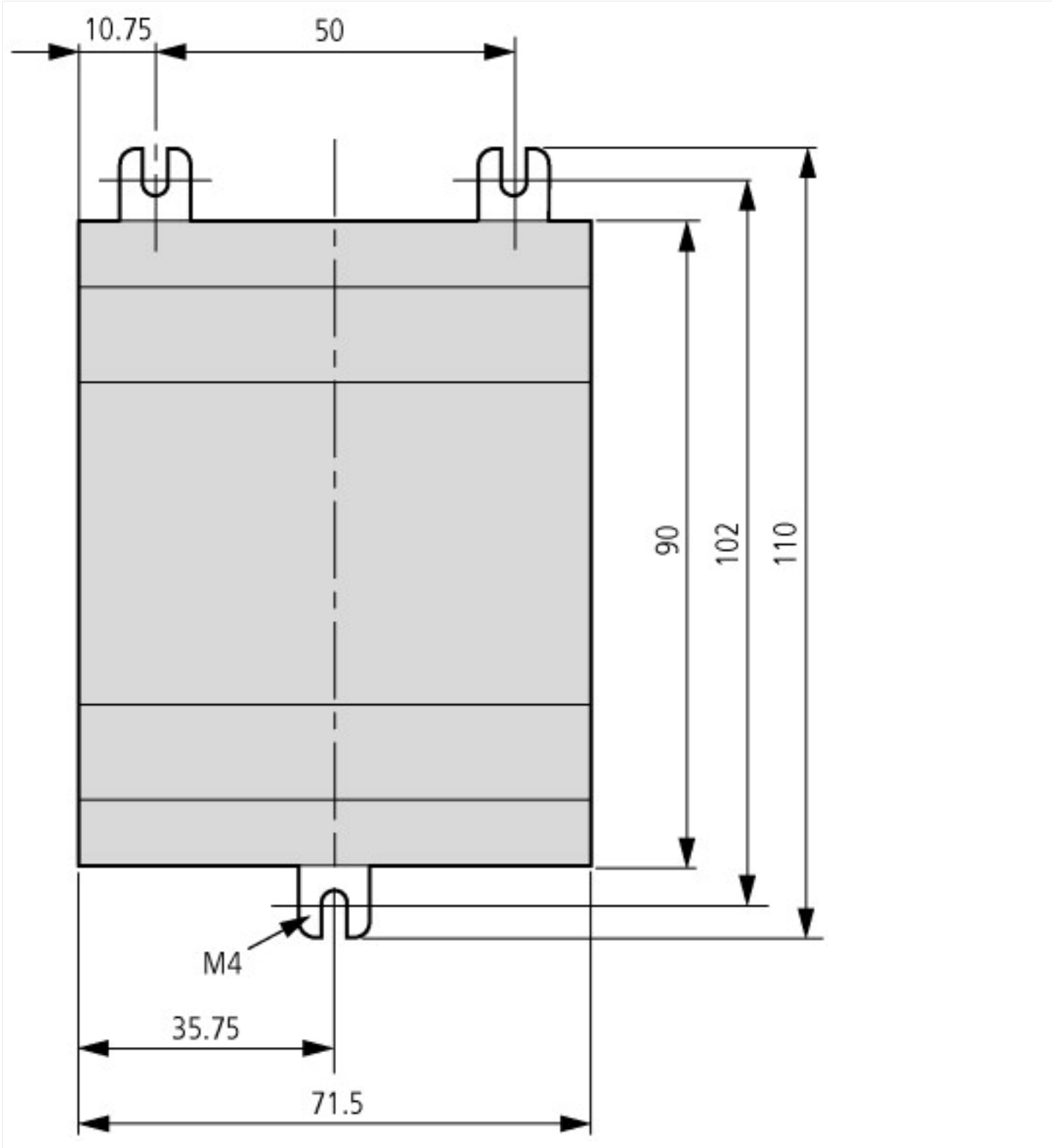

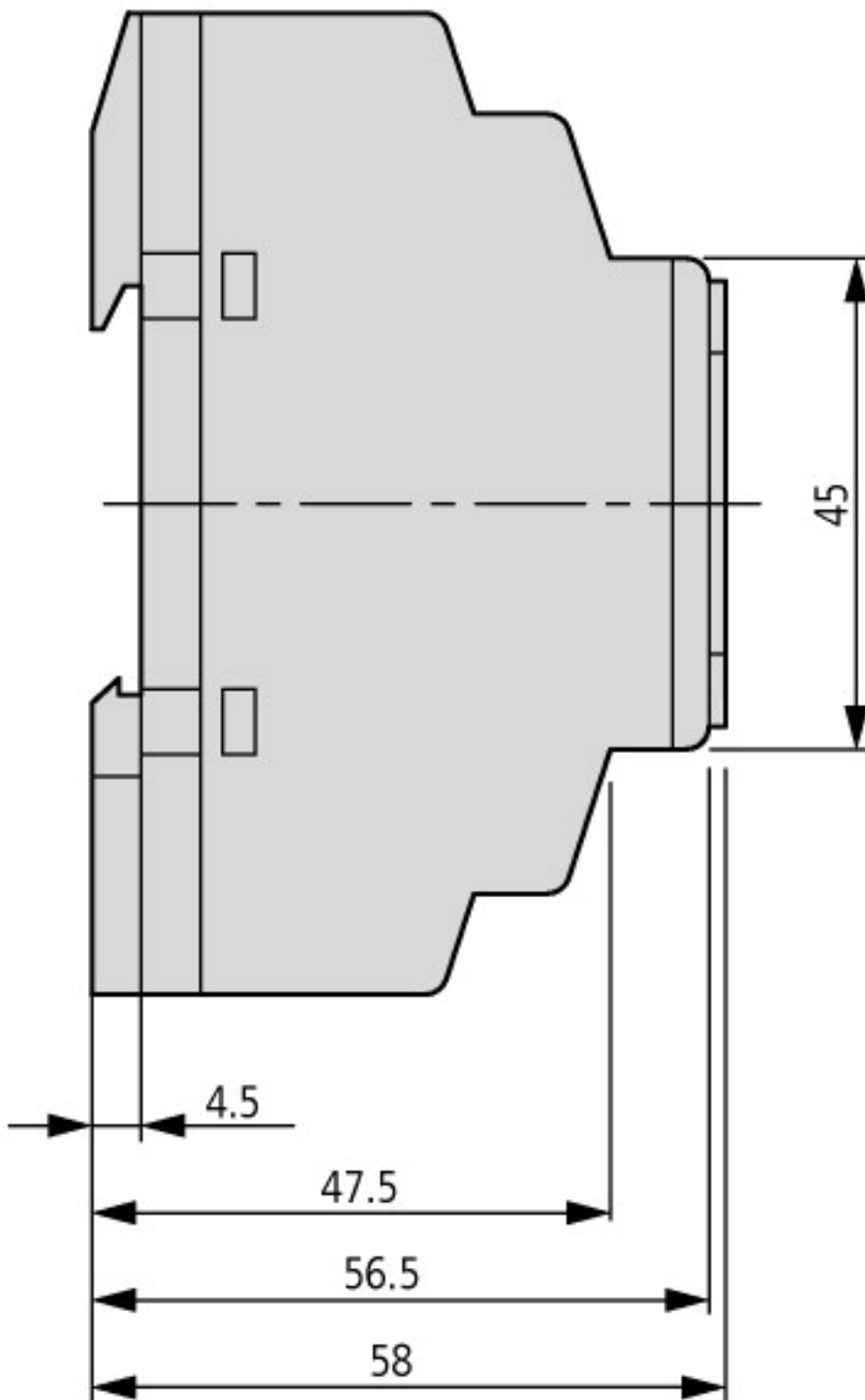

Additional product information (links)

Instruction leaflet "power supply unit" IL05012003Z (AWA2727-1869)

Instruction leaflet "power supply unit" IL05012003Z (AWA2727-1869)	ftp://ftp.moeller.net/DOCUMENTATION/AWA_INSTRUCTIONS/IL05012003Z.pdf
Instruction leaflet "power supply unit" IL05012003Z (AWA2727-1869)	ftp://ftp.moeller.net/DOCUMENTATION/AWA_INSTRUCTIONS/IL05012003Z2010_11.pdf
Instruction leaflet "power supply unit" IL05012003Z (AWA2727-1869)	ftp://ftp.moeller.net/DOCUMENTATION/AWA_INSTRUCTIONS/IL05012003Z2016_04.pdf

Manual "easy800 control relays" MN04902001Z (AWB2528-1423)

MN04902001Z (AWB2528-1423) Steuerrelais easy800 - Deutsch	ftp://ftp.moeller.net/DOCUMENTATION/AWB_MANUALS/MN04902001Z_DE.pdf
MN04902001Z (AWB2528-1423) easy800 control relay - English	ftp://ftp.moeller.net/DOCUMENTATION/AWB_MANUALS/MN04902001Z_EN.pdf

Manual "easy500, easy700 control relays" MN05013003Z (AWB2528-1508)

MN05013003Z (AWB2528-1508) Steuerrelais easy500, easy700 - Deutsch	ftp://ftp.moeller.net/DOCUMENTATION/AWB_MANUALS/MN05013003Z_DE.pdf
--	---

MN05013003Z (AWB2528-1508) easy500, easy700 control relay - English	ftp://ftp.moeller.net/DOCUMENTATION/AWB_MANUALS/MN05013003Z_EN.pdf
Manual "easyControl, EC4-200 programmable PLC" MN05003003Z	
MN05003003Z Handbuch easyControl, Programmierbare Steuerung EC4-200 - Deutsch	ftp://ftp.moeller.net/DOCUMENTATION/AWB_MANUALS/MN05003003Z_DE.pdf
MN05003003Z Manual easyControl, programmable PLC EC4-200 - English	ftp://ftp.moeller.net/DOCUMENTATION/AWB_MANUALS/MN05003003Z_EN.pdf