



Soft starter, 3p, 37kW, I<sub>e</sub>=68A

Part no. **DS6-340-37K-MX**  
 Article no. **103088**  
 Catalog No. **DS6-340-37K-MX**

## Delivery program

Description			With internal bypass contacts
Function			Soft starters for three-phase loads
Mains supply voltage (50/60 Hz)	U <sub>LN</sub>	V AC	230 - 480
Supply voltage	U <sub>s</sub>		24 V DC
Control voltage	U <sub>C</sub>		24 V DC
<b>Assigned motor rating (Standard connection, In-Line)</b>			
at 400 V, 50 Hz	P	kW	37
at 460 V, 60 Hz	P	HP	50
<b>Rated operational current</b>			
AC-53	I <sub>e</sub>	A	68
Startup class			CLASS 10 (star-delta replacement) CLASS 20 (heavy starting duty 3 x I <sub>e</sub> for 45 s)
Rated operational voltage	U <sub>e</sub>		230 V 400 V 480 V

## Technical data

### General

Standards			IEC/EN 60947-4-2 UL 508 CSA22.2-14 GB14048
Approvals			CE
Approvals			UL CSA C-Tick UkrSEPRO CCC
Climatic proofing			Damp heat, constant, to IEC 60068-2-3 Damp heat, cyclic, to IEC 60068-2-10
Ambient temperature			
Operation	θ	°C	0 - +40 up to 60 at 1 % derating per Kelvin temperature rise
Storage	θ	°C	-25 - +55
Altitude		m	0 - 1000 m, above that 1 % derating per 100 m , up to 2000 m
Mounting position			Vertical
Degree of protection			
Degree of Protection			IP20 (terminals IP00)
Integrated			Protection type IP40 can be achieved on all sides with covers from the NZM range.
Protection against direct contact			Finger and back-of-hand proof
Overvoltage category/pollution degree			II/2
Shock resistance			8 g/11 ms
Vibration resistance to EN 60721-3-2			2M2
Radio interference level (IEC/EN 55011)			A
Weight		kg	1.8

### Main conducting paths

Rated operating voltage	U <sub>e</sub>	V AC	230 - 480
Supply frequency	f <sub>LN</sub>	Hz	50/60
Rated operational current	I <sub>e</sub>	A	
AC-53	I <sub>e</sub>	A	68
<b>Assigned motor rating (Standard connection, In-Line)</b>			
at 230 V, 50 Hz	P	kW	15

at 400 V, 50 Hz	P	kW	37
at 230 V, 60 Hz	P	HP	25
at 460 V, 60 Hz	P	HP	50
Overload cycle to IEC/EN 60947-4-2			
AC-53a			68 A: AC-53a: 3 - 5: 75 - 10
Internal bypass contacts			●
Short-circuit rating			
Type "1" coordination			NZMN1-M80
Type „2“ coordination (additional with the fuses for coordination type „1“)			3 x 20.610.32-200
Fuse base (number x part no.)			3 x 21.313.02

### Terminal capacities

Cable lengths			
Solid		mm <sup>2</sup>	1 x (25 - 70) 2 x (6 - 25)
Stranded		mm <sup>2</sup>	1 x (25 - 70) 2 x (6 - 25)
Solid or stranded		AWG	1 x (12 - 2/0)
Copper band		MM	2 x 9 x 0.8 9 x 9 x 0.9
Tightening torque		Nm	6 (≤ 10 mm <sup>2</sup> ); 9 (> 10 mm <sup>2</sup> )
Screwdriver (PZ: Pozidriv)		mm	PZ2; 1 x 6 mm
Control cables			
Solid		mm <sup>2</sup>	1 x (0.5 - 2.5) 2 x (0.5 - 1.0)
Flexible with ferrule		mm <sup>2</sup>	1 x (0.5 - 1.5) 2 x (0.5 - 0.75)
Stranded		mm <sup>2</sup>	1 x (0.5 - 1.5) 2 x (0.5 - 1.0)
Solid or stranded		AWG	1 x (21 - 14) 2 x (21 - 18)
Tightening torque		Nm	0.4
Screwdriver		mm	0,6 x 3,5

### Control circuit

Digital inputs			
Control voltage			
DC-operated		V DC	24 V DC +10 %/- 15 %
Current consumption 24 V		mA	
External 24 V (no-load)		mA	14
Pick-up voltage		x U <sub>s</sub>	
DC-operated		V DC	17.3 - 27
Drop-out voltage	x U <sub>s</sub>		
DC operated		V DC	0 - 3
Pick-up time			
DC operated		ms	250
Drop-out time			
DC operated		ms	190
Regulator supply			
Voltage	U <sub>s</sub>	V	24 V DC +10 %/- 15 %
Current consumption	I <sub>e</sub>	mA	65
Current consumption at peak performance (close bypass) at 24 V DC	I <sub>Peak</sub>	A/ms	0,6/50
Notes			External supply voltage
Relay outputs			
Number			2 (TOR, Ready)
Voltage range		V AC	250
AC-11 current range		A	3 A, AC-11

### Soft start function

Ramp times			
Acceleration		s	1 - 30

Deceleration	s	0 - 30
Start voltage (= turn-off voltage)	%	30 - 100
Start pedestal	%	30 - 100
Fields of application		
Fields of application		Soft starting of three-phase asynchronous motors
3-phase motors		●

## Functions

Fast switching (semiconductor contactor)		- (minimum ramp time 1s)
Soft start function		●
Reversing starter		External solution required
Suppression of closing transients		●
Suppression of DC components for motors		●
Potential isolation between power and control sections		●

## Notes

Rated impulse withstand voltage:

- 1.2 μs/50 μs (rise time/fall time of the pulse to IEC/EN 60947-2 or -3)
- Applies for control circuit/power section/enclosure

## Technical data ETIM 6.0

Low-voltage industrial components (EG000017) / Soft starter (EC000640)

Electric engineering, automation, process control engineering / Low-voltage switch technology / Load breakout, motor breakout / Semiconductor motor controller or soft starter (ec@ss8.1-27-37-09-07 [ACO300008])

Rated operation current I <sub>e</sub> at 40 °C Tu	A	68
Rated operating voltage U <sub>e</sub>	V	230 - 460
Rated power three-phase motor, inline, at 230 V	kW	15
Rated power three-phase motor, inline, at 400 V	kW	37
Rated power three-phase motor, inside delta, at 230 V	kW	0
Rated power three-phase motor, inside delta, at 400 V	kW	0
Internal bypass		Yes
With display		No
Torque control		No
Rated surrounding temperature without derating	°C	40
Rated control supply voltage U <sub>s</sub> at AC 50HZ	V	0 - 0
Rated control supply voltage U <sub>s</sub> at AC 60HZ	V	0 - 0
Rated control supply voltage U <sub>s</sub> at DC	V	24 - 24
Voltage type for actuating		DC
Integrated motor overload protection		No

## Approvals

Product Standards		IEC/EN 60947-4-2; GB 14048.6; UL 508; CSA-C22.2 No 0-M91; CSA-C22.2 No 14-05 CE marking
UL File No.		E251034
UL Category Control No.		NMFT
CSA File No.		012528
CSA Class No.		3211-06
North America Certification		UL listed, CSA certified
Specially designed for North America		No
Suitable for		Branch circuits
Current Limiting Circuit-Breaker		No
Max. Voltage Rating		480 V
Degree of Protection		IP20; UL/CSA Type 1

## Dimensions

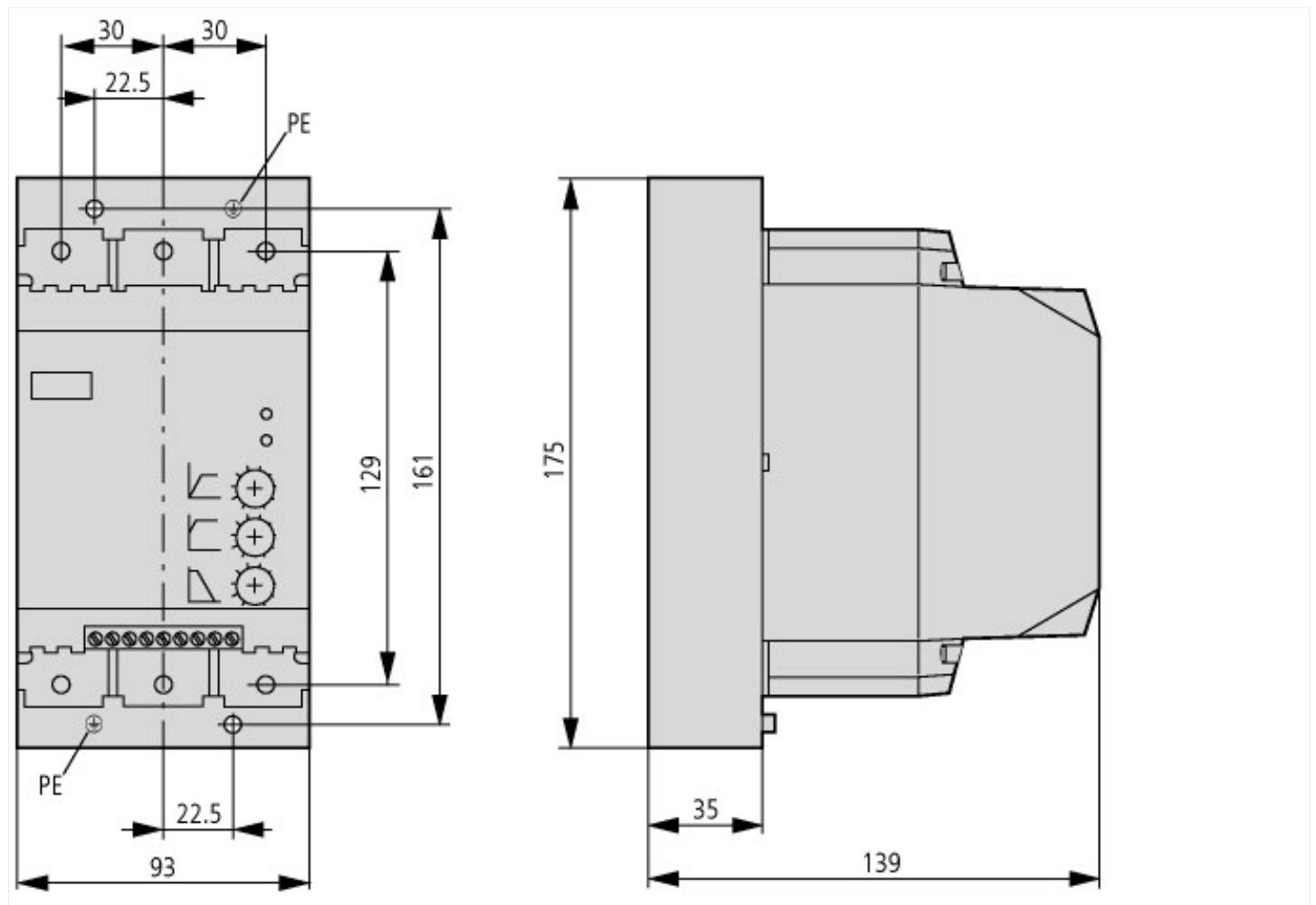

## Additional product information (links)

### AWA8250-2330 Soft starter DS6

AWA8250-2330 Soft starter DS6 [ftp://ftp.moeller.net/DOCUMENTATION/AWA\\_INSTRUCTIONS/23300609.pdf](ftp://ftp.moeller.net/DOCUMENTATION/AWA_INSTRUCTIONS/23300609.pdf)

### MN03902001Z (AWB8250-1346) Design of soft starters

MN03902001Z (AWB8250-1346) Auslegung von Softstartern - Deutsch [ftp://ftp.moeller.net/DOCUMENTATION/AWB\\_MANUALS/MN03902001Z\\_DE.pdf](ftp://ftp.moeller.net/DOCUMENTATION/AWB_MANUALS/MN03902001Z_DE.pdf)

MN03902001Z (AWB8250-1346) Design of soft starters - English [ftp://ftp.moeller.net/DOCUMENTATION/AWB\\_MANUALS/MN03902001Z\\_EN.pdf](ftp://ftp.moeller.net/DOCUMENTATION/AWB_MANUALS/MN03902001Z_EN.pdf)