



Switch-disconnector, 3 pole, 160 A, Without rotary handle and drive shaft, surface mounting, Screw terminal, drilling dimension 6,5 mm

Part no. DMV-160N/3
Article no. 1814178

Delivery program

| | | | |
|---|-------|-----|--|
| Product range | | | Switch-disconnector Main switch maintenance switch |
| Part group reference | | | DMV |
| Stop Function | | | optional Without rotary handle and drive shaft |
| Notes | | | visible contacts |
| Information about equipment supplied | | | auxiliary contact fitted by user. including connection materials |
| Number of poles | | | 3 pole |
| Auxiliary contacts | | | |
|  | | N/O | 0 |
|  | | N/C | 0 |
| Degree of Protection | | | IP00 IP20 with terminal cover |
| Design | | | surface mounting  |
| Contact sequence | | |  |
| Motor rating AC-23A, 50 - 60 Hz | | | |
| 400 V | P | kW | 90 |
| Rated uninterrupted current | I_u | A | 160 |
| Connection technique | | | Screw terminal, drilling dimension 6,5 mm |

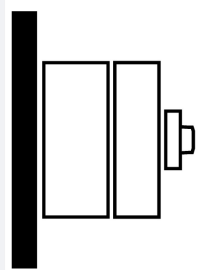
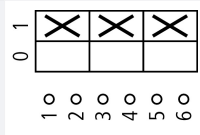
Technical data

| | | | |
|---|-----------|----|--|
| General | | | |
| Standards | | | IEC/EN 60947, VDE 0660, IEC/EN 60204, Switch-disconnector according to IEC/EN 60947-3 |
| Certifications | | | CE, RoHs, KEMA, GOST-R, Lloyds |
| Ambient temperature | | | |
| Operation | θ | °C | -25 - +55 |
| Storage | θ | °C | -30 - +80 |
| Overvoltage category/pollution degree | | | III/3 |
| Rated impulse withstand voltage | U_{imp} | kV | 8 |
| Rated insulation voltage | U_i | V | 1000 |
| Mounting position | | | As required |
| Protection against direct contact when actuated from front (EN 50274) | | | Finger and back-of-hand proof |

Contacts

| | | | |
|---|----------|-----------|--|
| Mechanical variables | | | |
| Number of poles | | | 3 pole |
| Auxiliary contacts | | | |
| | | N/O | 0 |
| | | N/C | 0 |
| Electrical characteristics | | | |
| Rated operational voltage | U_e | V AC | 690 |
| Rated uninterrupted current | I_u | A | 160 |
| Note on rated uninterrupted current I_u | | | Rated uninterrupted current I_u is specified for max. cross-section. |
| Short-circuit rating | | | |
| fuse | | | 160/100 |
| Rated conditional short-circuit current | I_q | kA | $I_n = 160: 50$ $I_n = 100: 100$ |
| Breaking current | | kA | $I_n = 160: 50$ $I_n = 100: 14.5$ |
| max. let-through energy | | kA^2s | $I_n = 160: 600$ $I_n = 100: 67$ |
| Rated short-time withstand current (1 s current) | I_{cw} | A_{rms} | 8000 |
| Note on rated short-time withstand current I_{cw} | | | Current for a time of 0.2 seconds |

Switching capacity

| | | | |
|---|------------|----|-------|
| Rated breaking capacity $\cos \varphi$ to IEC 60947-3 | | | |
| 400/415 V | | A | 1232 |
| 500 V | | A | 848 |
| Safe isolation to EN 61140 | | | |
| Current heat loss per contact at I_e | | W | 3.9 |
| Lifespan, mechanical | | | |
| | Operations | | 10000 |
| AC | | | |
| AC-21A | | | |
| Rated operational current switch | | | |
| 400 V 415 V | I_e | A | 160 |
| 500 V | I_e | A | 160 |
| 690 V | I_e | A | 125 |
| AC-22A | | | |
| Rated operational current switch | | | |
| 400 V 415 V | I_e | A | 160 |
| 500 V | I_e | A | 160 |
| 690 V | I_e | A | 125 |
| AC-23A | | | |
| Rated operational current switch | | | |
| 400 V 415 V | I_e | A | 154 |
| 500 V | I_e | A | 106 |
| Motor rating AC-23A, 50 - 60 Hz | | | |
| 400 V 415 V | P | kW | 90 |
| 500 V | P | kW | 75 |

Terminal capacities

| | | | |
|--|--|--------|---------|
| Flat conductor connection with busbars | | mm^2 | 75 |
| Terminal screw | | | M6 x 16 |

Technical safety parameters:

| | | | |
|--------------|--|--|---|
| Notes | | | B10 _q values as per EN ISO 13849-1, table C1 |
|--------------|--|--|---|

Design verification as per IEC/EN 61439

| | | | |
|--|-----------|---|-----|
| Technical data for design verification | | | |
| Rated operational current for specified heat dissipation | I_n | A | 160 |
| Heat dissipation per pole, current-dependent | P_{vid} | W | 3.9 |
| Equipment heat dissipation, current-dependent | P_{vid} | W | 0 |

| | | | |
|--|------------|----|--|
| Static heat dissipation, non-current-dependent | P_{vs} | W | 0 |
| Heat dissipation capacity | P_{diss} | W | 0 |
| Operating ambient temperature min. | | °C | -25 |
| Operating ambient temperature max. | | °C | 55 |
| IEC/EN 61439 design verification | | | |
| 10.2 Strength of materials and parts | | | |
| 10.2.2 Corrosion resistance | | | Meets the product standard's requirements. |
| 10.2.3.1 Verification of thermal stability of enclosures | | | Meets the product standard's requirements. |
| 10.2.3.2 Verification of resistance of insulating materials to normal heat | | | Meets the product standard's requirements. |
| 10.2.3.3 Verification of resistance of insulating materials to abnormal heat and fire due to internal electric effects | | | Meets the product standard's requirements. |
| 10.2.4 Resistance to ultra-violet (UV) radiation | | | Meets the product standard's requirements. |
| 10.2.5 Lifting | | | Does not apply, since the entire switchgear needs to be evaluated. |
| 10.2.6 Mechanical impact | | | Does not apply, since the entire switchgear needs to be evaluated. |
| 10.2.7 Inscriptions | | | Meets the product standard's requirements. |
| 10.3 Degree of protection of ASSEMBLIES | | | Does not apply, since the entire switchgear needs to be evaluated. |
| 10.4 Clearances and creepage distances | | | Meets the product standard's requirements. |
| 10.5 Protection against electric shock | | | Does not apply, since the entire switchgear needs to be evaluated. |
| 10.6 Incorporation of switching devices and components | | | Does not apply, since the entire switchgear needs to be evaluated. |
| 10.7 Internal electrical circuits and connections | | | Is the panel builder's responsibility. |
| 10.8 Connections for external conductors | | | Is the panel builder's responsibility. |
| 10.9 Insulation properties | | | |
| 10.9.2 Power-frequency electric strength | | | Is the panel builder's responsibility. |
| 10.9.3 Impulse withstand voltage | | | Is the panel builder's responsibility. |
| 10.9.4 Testing of enclosures made of insulating material | | | Is the panel builder's responsibility. |
| 10.10 Temperature rise | | | The panel builder is responsible for the temperature rise calculation. Eaton will provide heat dissipation data for the devices. |
| 10.11 Short-circuit rating | | | Is the panel builder's responsibility. The specifications for the switchgear must be observed. |
| 10.12 Electromagnetic compatibility | | | Is the panel builder's responsibility. The specifications for the switchgear must be observed. |
| 10.13 Mechanical function | | | The device meets the requirements, provided the information in the instruction leaflet (IL) is observed. |

Technical data ETIM 6.0

| | | | |
|--|--|----|-----------|
| Low-voltage industrial components (EG000017) / Switch disconnecter (EC000216) | | | |
| Electric engineering, automation, process control engineering / Low-voltage switch technology / Off-load switch, circuit breaker, control switch / Switch disconnecter (ecl@ss8.1-27-37-14-03 [AKF060010]) | | | |
| Version as main switch | | | Yes |
| Version as maintenance-/service switch | | | Yes |
| Version as safety switch | | | No |
| Version as emergency stop installation | | | Yes |
| Version as reversing switch | | | No |
| Max. rated operation voltage U_e AC | | V | 690 |
| Rated operating voltage | | V | 690 - 690 |
| Rated permanent current I_u | | A | 160 |
| Rated permanent current at AC-21, 400 V | | A | 160 |
| Rated operation power at AC-3, 400 V | | kW | 0 |
| Rated short-time withstand current I_{cw} | | kA | 8 |
| Rated operation power at AC-23, 400 V | | kW | 90 |
| Switching power at 400 V | | kW | 90 |
| Conditioned rated short-circuit current I_q | | kA | 100 |
| Number of poles | | | 3 |
| Number of auxiliary contacts as normally closed contact | | | 0 |
| Number of auxiliary contacts as normally open contact | | | 0 |
| Number of auxiliary contacts as change-over contact | | | 0 |
| Motor drive optional | | | No |

| | |
|---|----------------------------|
| Motor drive integrated | No |
| Voltage release optional | No |
| Device construction | Complete device in housing |
| Suitable for ground mounting | Yes |
| Suitable for front mounting 4-hole | No |
| Suitable for front mounting center | No |
| Suitable for distribution board installation | Yes |
| Suitable for intermediate mounting | No |
| Colour control element | - |
| Type of control element | - |
| Interlockable | No |
| Type of electrical connection of main circuit | Screw connection |
| Degree of protection (IP), front side | IP20 |

Dimensions

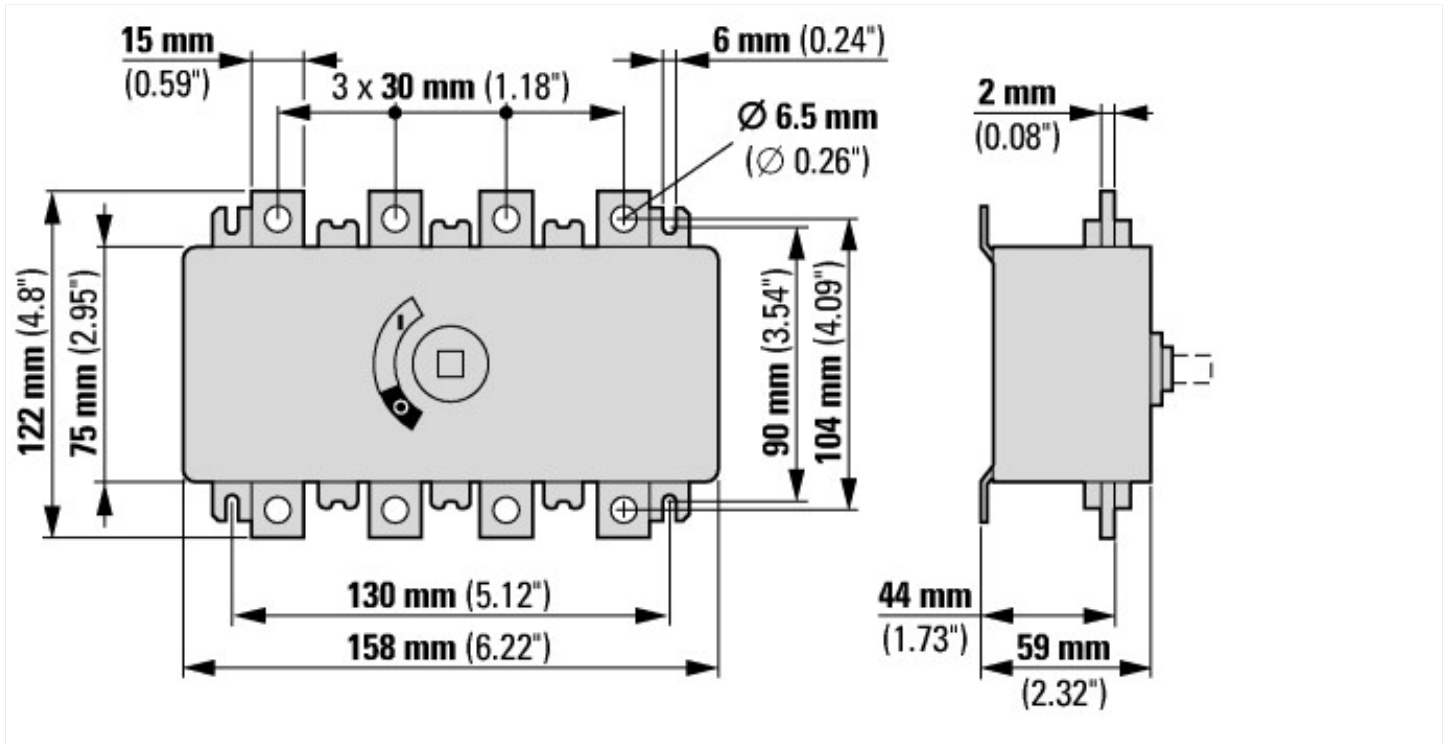

Additional product information (links)

IL008008Z Switch-disconnectors

IL008008Z Switch-disconnectors

ftp://ftp.moeller.net/DOCUMENTATION/AWA_INSTRUCTIONS/IL008008ZU2016_11.pdf