



**Contactor, 4p+1N/C, 45A/AC1**

**Part no.** DILMP45-01(230V50HZ,240V60HZ)  
**Article no.** 118914  
**Catalog No.** XTCF045C01F

**Delivery program**

Product range			Contactors
Application			Contactors for 4 pole electric consumers
Subrange			Contactors up to 200 A, 4 pole
Utilization category			AC-1: Non-inductive or slightly inductive loads, resistance furnaces NAC-3: Normal AC induction motors: starting, switch off during running
Connection technique			Screw terminals
Number of poles			4 pole
<b>Rated operational current</b>			
AC-1			
Conventional free air thermal current, 3 pole, 50 - 60 Hz			
at 40 °C	$I_{th} = I_e$	A	45
at 50 °C	$I_{th} = I_e$	A	41
at 60 °C	$I_{th} = I_e$	A	39
Contact sequence			
For use with			DILM32-XHI(C)... DILA-XHI(V)(C)...
Actuating voltage			230 V 50 Hz, 240 V 60 Hz
Voltage AC/DC			AC operation
<b>Instructions</b>			Contacts to EN 50012. with mirror contact.

**Technical data**

<b>General</b>			
Standards			IEC/EN 60947, VDE 0660, UL, CSA
Lifespan, mechanical			
AC operated	Operations	$\times 10^6$	10
DC operated	Operations	$\times 10^6$	10
Operating frequency, mechanical			
AC operated	Operations/h		5000
DC operated	Operations/h		5000
Climatic proofing			Damp heat, constant, to IEC 60068-2-3 Damp heat, cyclic, to IEC 60068-2-30
Ambient temperature			
Open		°C	-25 - +60
Enclosed		°C	- 25 - 40
Storage		°C	- 40 - 80
Mounting position			
Mounting position			
Mechanical shock resistance (IEC/EN 60068-2-27)			
Half-sinusoidal shock, 10 ms			
Main contacts			
N/O contact		g	10

Auxiliary contacts			
N/O contact	g		7
N/C contact	g		5
Degree of Protection			IP00
Protection against direct contact when actuated from front (EN 50274)			Finger and back-of-hand proof
Terminal capacity main cable			
Solid	mm <sup>2</sup>		1 x (0.75 - 16) 2 x (0.75 - 10)
Flexible with ferrule	mm <sup>2</sup>		1 x (0.75 - 16) 2 x (0.75 - 10)
Stranded	mm <sup>2</sup>		1 x 16
Solid or stranded	AWG		18 - 6
Terminal capacity control circuit cables			
Solid	mm <sup>2</sup>		1 x (0.75 - 4) 2 x (0.75 - 2.5)
Flexible with ferrule	mm <sup>2</sup>		1 x (0.75 - 2.5) 2 x (0.75 - 2.5)
Solid or stranded	AWG		18 - 14
Main cable connection screw/bolt			M5
Tightening torque			Nm 3
Control circuit cable connection screw/bolt			M3.5
Tightening torque			Nm 1.2
Tool			
Main cable			
Pozidriv screwdriver	Size		2
Standard screwdriver	mm		0.8 x 5.5 1 x 6
Control circuit cables			
Pozidriv screwdriver	Size		2
Standard screwdriver	mm		0.8 x 5.5 1 x 6

### Main conducting paths

Rated impulse withstand voltage	U <sub>imp</sub>	V AC	8000
Overvoltage category/pollution degree			III/3
Rated insulation voltage	U <sub>i</sub>	V AC	690
Rated operational voltage	U <sub>e</sub>	V AC	690
Safe isolation to EN 61140			
between coil and contacts		V AC	440
between the contacts		V AC	440
Making capacity (cos φ)	Up to 690 V	A	350 According to IEC/EN 60947
Breaking capacity			
220 V 230 V		A	250
380 V 400 V		A	250
500 V		A	250
660 V 690 V		A	144
Short-circuit rating			
Short-circuit protection maximum fuse			
Type "2" coordination			
400 V	gG/gL 500 V	A	35
690 V	gG/gL 690 V	A	35
Type "1" coordination			
400 V	gG/gL 500 V	A	100
690 V	gG/gL 690 V	A	50

### AC

AC-1			
Rated operational current			
Conventional free air thermal current, 3 pole, 50 - 60 Hz			

Open			
at 40 °C	$I_{th} = I_e$	A	45
at 50 °C	$I_{th} = I_e$	A	41
at 60 °C	$I_{th} = I_e$	A	39
enclosed	$I_{th}$	A	36
Conventional free air thermal current, 1 pole			
open	$I_{th}$	A	117
enclosed	$I_{th}$	A	105
AC-3			
Rated operational current			
Open, 3-pole: 50 – 60 Hz			
220 V 230 V	$I_e$	A	25
240 V	$I_e$	A	25
380 V 400 V	$I_e$	A	25
415 V	$I_e$	A	25
440V	$I_e$	A	25
500 V	$I_e$	A	25
660 V 690 V	$I_e$	A	15
Motor rating			
220 V 230 V	P	kWh	
240V	P	kW	7.5
380 V 400 V	P	kW	8.5
415 V	P	kW	11
440 V	P	kW	14.5
500 V	P	kW	15.5
660 V 690 V	P	kW	17.5
			14

## DC

Rated operational current, open			
DC-1			
60 V	$I_e$	A	45
110 V	$I_e$	A	45
220 V	$I_e$	A	45
440 V	$I_e$	A	3
DC-3			
60 V	$I_e$	A	45
110 V	$I_e$	A	45
220 V	$I_e$	A	45
440 V	$I_e$	A	3
DC-5			
60 V	$I_e$	A	45
110 V	$I_e$	A	32
220 V	$I_e$	A	22
440 V	$I_e$	A	3

## Current heat loss

3-pole at $I_{th}$		W	12
Impedance per pole		mΩ	1.5

## Magnet systems

Voltage tolerance			
AC operated 50 Hz	Pick-up	$x U_c$	0.8 - 1.1
AC operated 50/60 Hz		$x U_c$	0.85 - 1.1
Drop-out voltage AC operated	Drop-out	$x U_c$	0.4 - 0.6
DC operated	Pick-up	$x U_c$	0.7 - 1.2
DC operated	Drop-out	$x U_c$	0.2 - 0.6

Power consumption of the coil in a cold state and $1.0 \times U_C$				
AC operated 50/60 Hz	Pick-up	VA		50
AC operated 50/60 Hz	Pick-up	W		40
AC operated 50/60 Hz	Sealing	VA		8
AC operated 50/60 Hz	Sealing	W		2.4
DC operated	Pick-up	W		12
DC operated	Sealing	W		0.5
Duty factor		% DF		100
Changeover time at 100 % $U_C$ (recommended value)				
Main contacts				
AC operated				
Closing delay		ms		16 - 22
Opening delay		ms		8 - 14
DC operated				
Closing delay		ms		47
Opening delay		ms		30
Arcing time		ms		10
Permissible residual current with actuation of A1 - A2 by the electronics (with 0 signal).		mA		$\leq 1$

## Design verification as per IEC/EN 61439

Technical data for design verification				
Rated operational current for specified heat dissipation	$I_n$	A		45
Heat dissipation per pole, current-dependent	$P_{vid}$	W		4.4
Equipment heat dissipation, current-dependent	$P_{vid}$	W		13.2
Static heat dissipation, non-current-dependent	$P_{vs}$	W		2.1
Heat dissipation capacity	$P_{diss}$	W		0
Operating ambient temperature min.		°C		-25
Operating ambient temperature max.		°C		60
IEC/EN 61439 design verification				
10.2 Strength of materials and parts				
10.2.2 Corrosion resistance				Meets the product standard's requirements.
10.2.3.1 Verification of thermal stability of enclosures				Meets the product standard's requirements.
10.2.3.2 Verification of resistance of insulating materials to normal heat				Meets the product standard's requirements.
10.2.3.3 Verification of resistance of insulating materials to abnormal heat and fire due to internal electric effects				Meets the product standard's requirements.
10.2.4 Resistance to ultra-violet (UV) radiation				Meets the product standard's requirements.
10.2.5 Lifting				Does not apply, since the entire switchgear needs to be evaluated.
10.2.6 Mechanical impact				Does not apply, since the entire switchgear needs to be evaluated.
10.2.7 Inscriptions				Meets the product standard's requirements.
10.3 Degree of protection of ASSEMBLIES				Does not apply, since the entire switchgear needs to be evaluated.
10.4 Clearances and creepage distances				Meets the product standard's requirements.
10.5 Protection against electric shock				Does not apply, since the entire switchgear needs to be evaluated.
10.6 Incorporation of switching devices and components				Does not apply, since the entire switchgear needs to be evaluated.
10.7 Internal electrical circuits and connections				Is the panel builder's responsibility.
10.8 Connections for external conductors				Is the panel builder's responsibility.
10.9 Insulation properties				
10.9.2 Power-frequency electric strength				Is the panel builder's responsibility.
10.9.3 Impulse withstand voltage				Is the panel builder's responsibility.
10.9.4 Testing of enclosures made of insulating material				Is the panel builder's responsibility.
10.10 Temperature rise				The panel builder is responsible for the temperature rise calculation. Eaton will provide heat dissipation data for the devices.
10.11 Short-circuit rating				Is the panel builder's responsibility. The specifications for the switchgear must be observed.
10.12 Electromagnetic compatibility				Is the panel builder's responsibility. The specifications for the switchgear must be observed.

## Technical data ETIM 6.0

Low-voltage industrial components (EG000017) / Power contactor, AC switching (EC000066)		
Electric engineering, automation, process control engineering / Low-voltage switch technology / Contactor (LV) / Power contactor, AC switching (ecl@ss8.1-27-37-10-03 [AAB718012])		
Rated control supply voltage Us at AC 50HZ	V	230 - 230
Rated control supply voltage Us at AC 60HZ	V	240 - 240
Rated control supply voltage Us at DC	V	0 - 0
Voltage type for actuating		AC
Rated operation current Ie at AC-1, 400 V	A	45
Rated operation current Ie at AC-3, 400 V	A	25
Rated operation power at AC-3, 400 V	kW	11
Rated operation current Ie at AC-4, 400 V	A	15
Rated operation power Ie at AC-4, 400 V	kW	7
Modular version		No
Number of auxiliary contacts as normally open contact		0
Number of auxiliary contacts as normally closed contact		1
Type of electrical connection of main circuit		Screw connection
Number of normally closed contacts as main contact		0
Number of main contacts as normally open contact		4

## Approvals

Product Standards		IEC/EN 60947-4-1; UL 508; CSA-C22.2 No. 14-05; CE marking
UL File No.		E29096
UL Category Control No.		NLDX
CSA File No.		012528
CSA Class No.		2411-03, 3211-04
North America Certification		UL listed, CSA certified
Specially designed for North America		No

## Characteristics

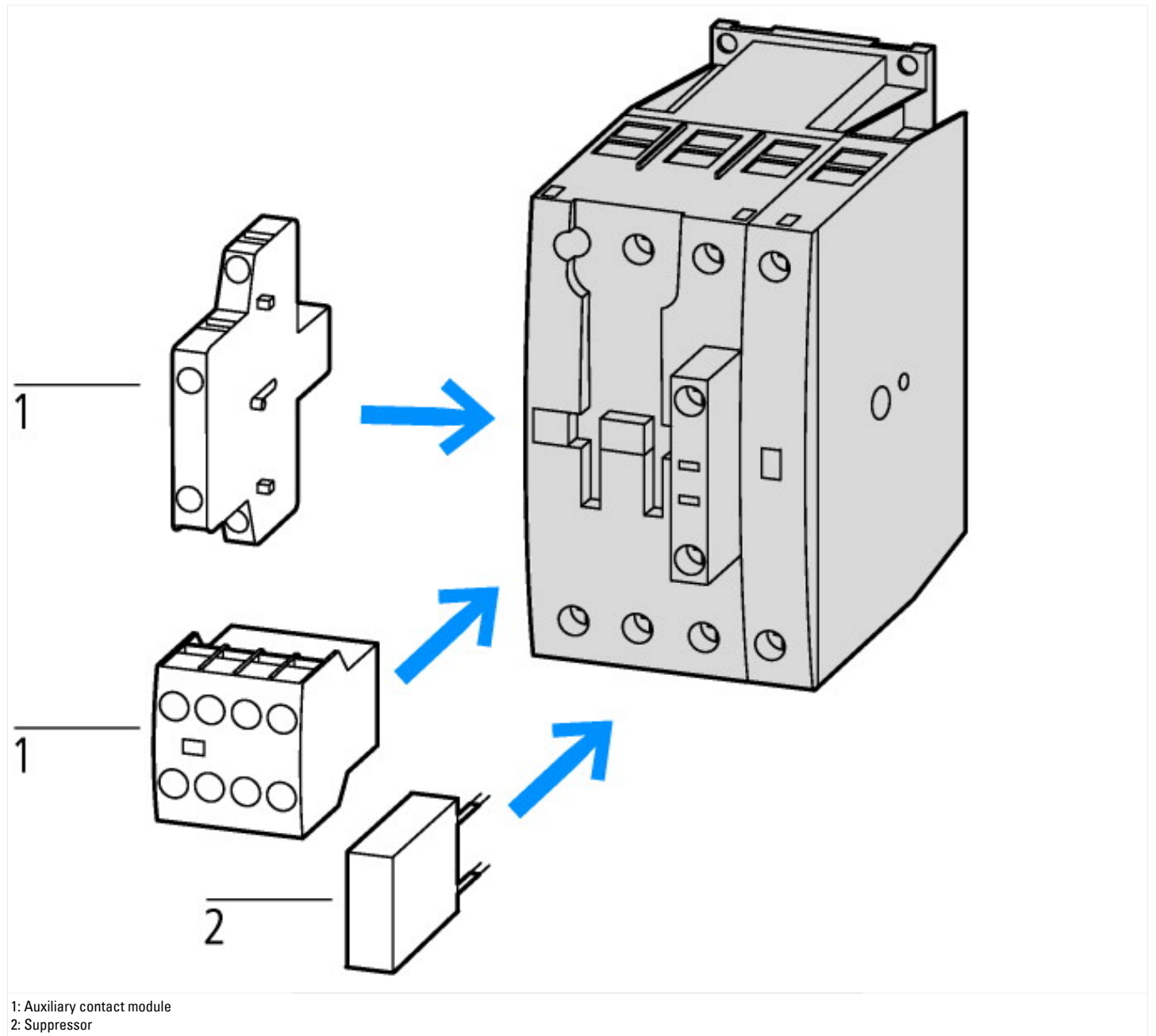

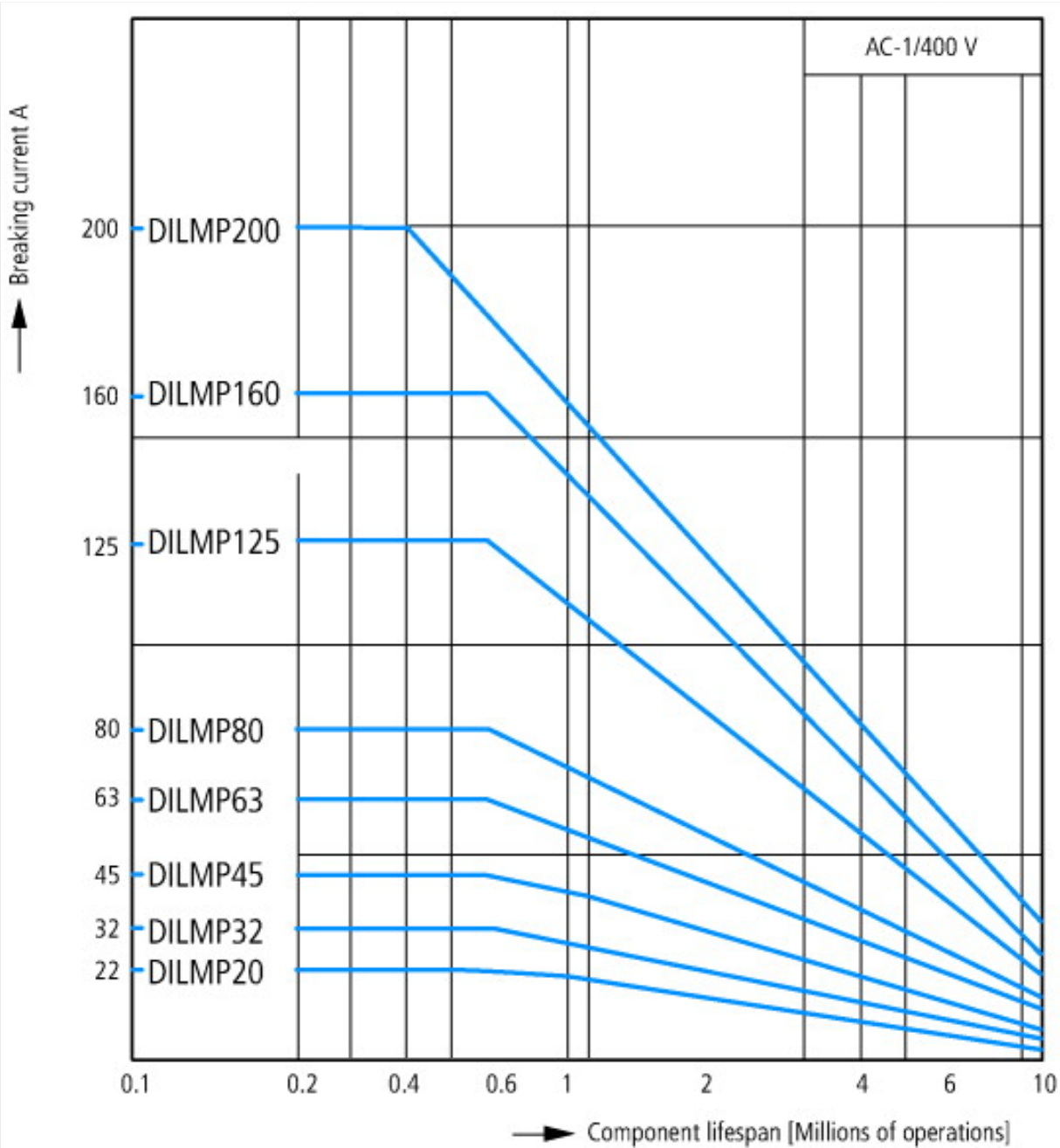

Switching conditions for 4 pole, non-motor loads  
 Operating characteristics  
 Non inductive and slightly inductive loads  
 Electrical characteristics  
 Switch on: 1 x rated operational current  
 Switch off: 1 x rated operational current  
 Utilization category  
 100 % AC-1  
 Typical examples of application  
 Electric heat

## Dimensions

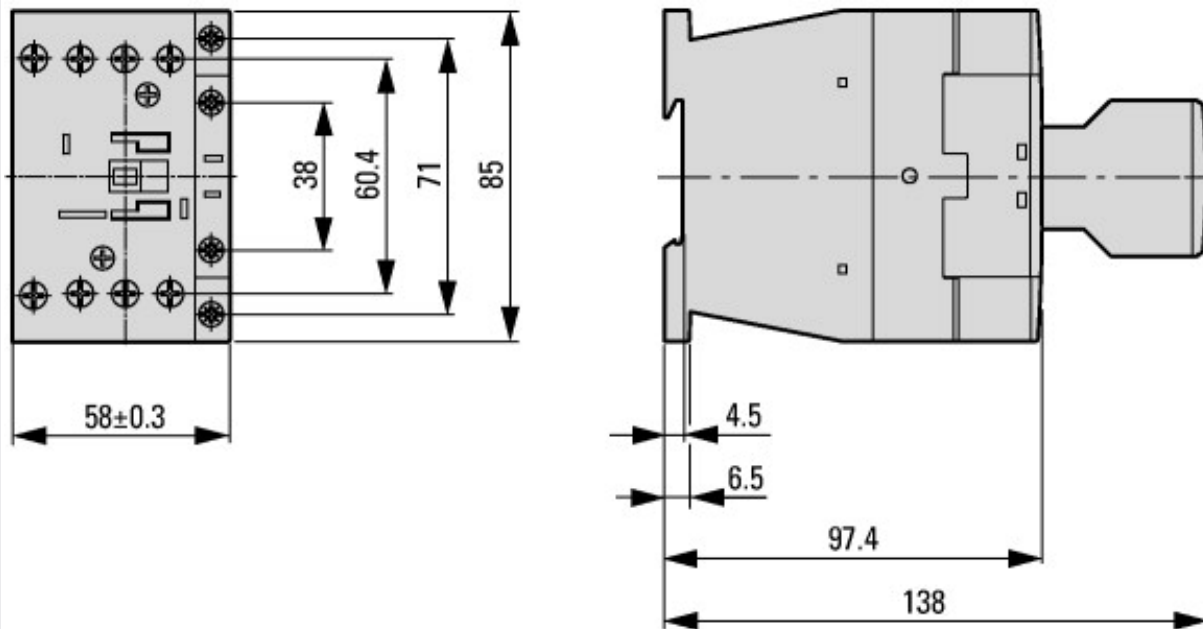

Contacteur with auxiliary contact module



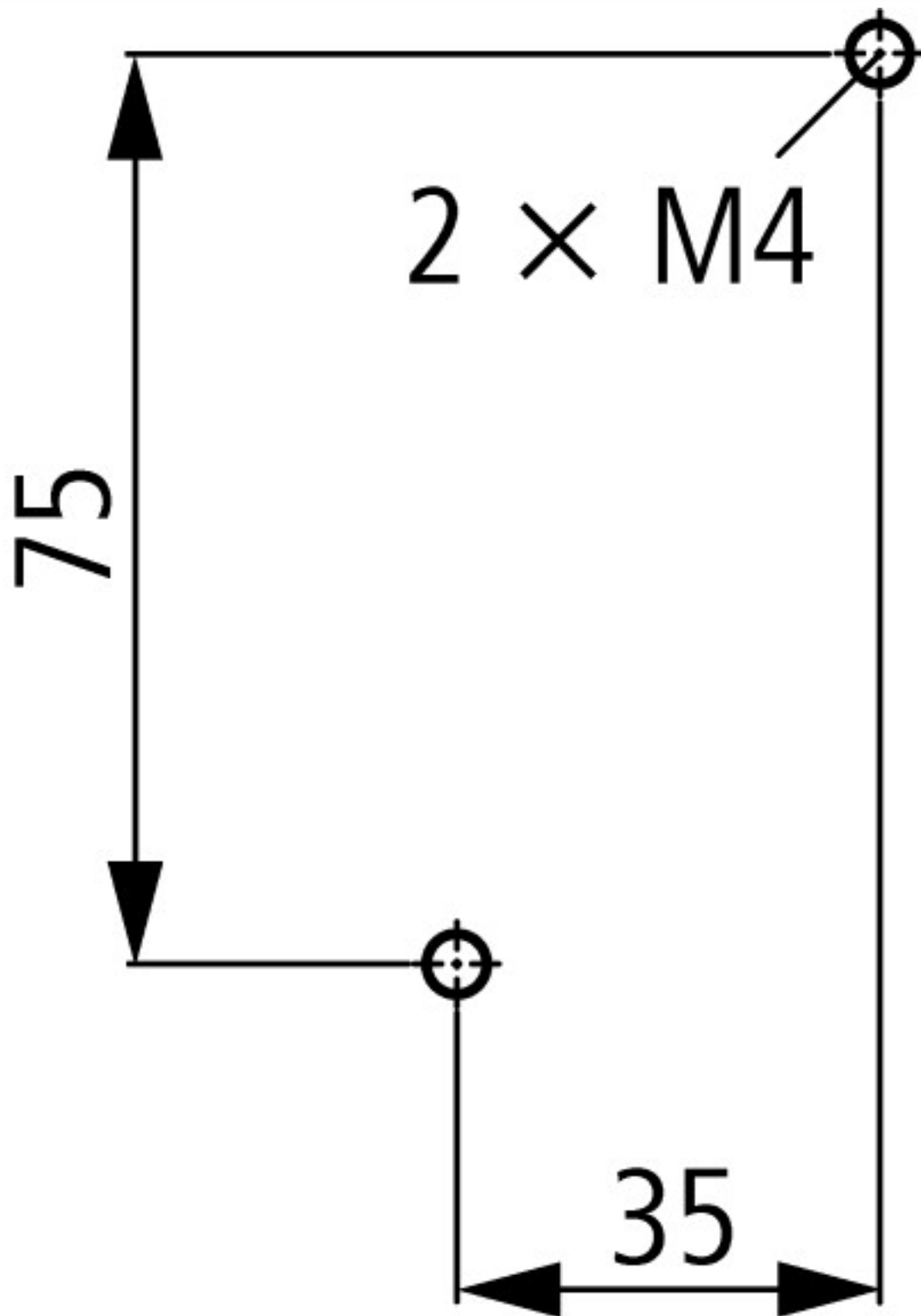

distance at side to earthed parts: 6 mm

DILMP32  
DILMP45

### Additional product information (links)

UL/CSA: UL/CSA: Special Purpose Rating	<a href="http://de.ecat.moeller.net/flip-cat?edition=HPLTE&amp;startpage=5.85">http://de.ecat.moeller.net/flip-cat?edition=HPLTE&amp;startpage=5.85</a>
Switchgear of Power Factor Correction Systems	<a href="http://www.moeller.net/binary/ver_techpapers/ver934en.pdf">http://www.moeller.net/binary/ver_techpapers/ver934en.pdf</a>
X-Start - Modern Switching Installations Efficiently Fitted and Wired Securely	<a href="http://www.moeller.net/binary/ver_techpapers/ver938en.pdf">http://www.moeller.net/binary/ver_techpapers/ver938en.pdf</a>
Mirror Contacts for Highly-Reliable Information Relating to Safety-Related Control Functions	<a href="http://www.moeller.net/binary/ver_techpapers/ver944en.pdf">http://www.moeller.net/binary/ver_techpapers/ver944en.pdf</a>
Effect of the Cabel Capacitance of Long Control Cables on the Actuation of Contactors	<a href="http://www.moeller.net/binary/ver_techpapers/ver949en.pdf">http://www.moeller.net/binary/ver_techpapers/ver949en.pdf</a>
Motor starters and "Special Purpose Ratings" for the North American market	<a href="http://www.moeller.net/binary/ver_techpapers/ver953en.pdf">http://www.moeller.net/binary/ver_techpapers/ver953en.pdf</a>
Switchgear for Luminaires	<a href="http://www.moeller.net/binary/ver_techpapers/ver955en.pdf">http://www.moeller.net/binary/ver_techpapers/ver955en.pdf</a>
Standard Compliant and Functionally Safe Engineering Design with Mechanical Auxiliary Contacts	<a href="http://www.moeller.net/binary/ver_techpapers/ver956en.pdf">http://www.moeller.net/binary/ver_techpapers/ver956en.pdf</a>

The Interaction of Contactors with PLCs	<a href="http://www.moeller.net/binary/ver_techpapers/ver957en.pdf">http://www.moeller.net/binary/ver_techpapers/ver957en.pdf</a>
Busbar Component Adapters for modern Industrial control panels	<a href="http://www.moeller.net/binary/ver_techpapers/ver960en.pdf">http://www.moeller.net/binary/ver_techpapers/ver960en.pdf</a>